

Olivehurst Public Utility District



Agenda Item Staff Report

Meeting Date: 02/15

Item description/summary:

Consider RFP for OPUD Advanced Metering Infrastructure Project.

Olivehurst Public Utility District (OPUD) released request for Bid for Advanced Metering Infrastructure on February 5, 2024, in order to stay on schedule for Grant Funding as this project is funded by the Department of Water Resources. The project entails the bid request for a new tower location for satellite communication for meter readings at Plumas Water Treatment Plant, Infrastructure for communication to existing tower off 1970 9th Ave, necessary equipment and labor required to have system up and running. This project will provide ease of meter reading and water losses tracking along with provide customer live readings of their water bill.

Fiscal Analysis:

Employee Feedback

n/a

Sample Motion:

Consider approving RFP for OPUD Advanced Metering Infrastructure Project.

Prepared by: Swarnjit Boyal, Public Work Engineer

EXHIBIT A – BID SET

OLIVEHURST PUBLIC UTILITY DISTRICT

Our mission is to provide high quality services to enhance our community's quality of life.



BOARD OF DIRECTORS

Dennise Burbank John Floe Mary Jane Griego Lacy Nelson Marc Perrault

GENERAL MANAGER

John Tillotson, P.E.

February 5, 2024

To: All Bidders

From: Swarnjit Boyal, MS, Public Works Engineer, OPUD

RE: RFP for Olivehurst Public Utility District Advanced Meter Infrastructure Project Bid

All,

The Olivehurst Public Utility District will be accepting bids for the construction, installation, and software support of the following items:

BID PROPOSAL REQUEST – OLIVEHURST PUBLIC UTILITY DISTRICT ADVANCED METERING INFRASTRUCTURE PROJECT BID		
Item No.	Est. Qty	Description
1	2	M400B2 Basestation (or equivalent)
2	2	Communication Backhaul
3	1	M400B2 Basestation (or equivalent) Install at Water Tower Site. No interference of radio frequency may occur with existing infrastructure in term of installation of basestation. Please coordinate with current Tower Leaser (AT&T or other).
4	1	M400B2 Basestation (or equivalent) Installation at New Tower Site - Includes New 80' Universal Aluminum Tower (see attached spec or provide recommended).
5	1	M400B2 Basestation (or equivalent) Certification
6	2,750	520M Single Port SmartPoint Radio Transmitters (or equivalent) (PURCHASE ONLY , no installation required). Must be Sensus Meter Touch Coupler compatible.
7	825	520M Dual Port SmartPoint Radio Transmitters (or equivalent) (PURCHASE ONLY , no installation required). Must be Sensus Meter Touch Coupler compatible.
8	1	12-Month Performance Bond + Labor & Material Bond
9	1	Regional Network Interface (RNI) Software as a service (SaaS) Setup (or equivalent)
10	1	Regional Network Interface (or equivalent) Training

**BID PROPOSAL REQUEST – OLIVEHURST PUBLIC UTILITY DISTRICT
ADVANCED METER INFRASTRUCTURE PROJECT BID**

Item No.	Est. Qty	Description
11	1	Sensus Analytics System (or equivalent) Setup
12	1	Sensus Analytics (or equivalent) Basic Integration
13	1	Sensus Analytics (or equivalent) Training
14	1	Network Implementation/ Consumer portal system set-up (with current District Billing software in conjunction with proposed AMI System). District Billing software upgrade is separate from this bid.
15	1	Annual Hosted RNI (or equivalent) Software-as-a-Service, Water Only (2 years) - (This bid will include first two years for this contract, known as initial start-up system integration and maintenance plus bug defusing, please send separate spreadsheet on cost for years 3-5).
16	1	Annual Sensus Analytics Enhanced (or equivalent) - Water Only (2 years) (This bid will include first two years for this contract, known as initial start-up system integration and maintenance plus bug defusing, please send separate spreadsheet on cost for years 3-5).
17	1	Annual Sensus Analytics (or equivalent) Text Messaging Fee (communication and relay to operators, first 2 years) - (This bid will include first two years for this contract, known as initial start-up system integration and maintenance plus bug defusing, please send separate spreadsheet on cost for years 3-5).
18	2	Annual M400 Basestation (or equivalent) Extended Warranty (2 years) - (This bid will include first two years for this contract, known as initial start-up system integration and maintenance plus bug defusing, please send separate spreadsheet on cost for years 3-5).
19	1	2 year Support – From local representative which include over the phone, in person, and remote access. (This bid will include first two years for this contract, known as initial start-up system integration and maintenance, please send separate spreadsheet on cost for years 3-5).

Bids will be accepted up through 2:00 pm **on March, 13th 2024** at which time bidding will close. Bid will be opened right after the same day. Please carefully read requirements for bid submittal.

Thank you very much for your interest in the project.

SECTION I – AMI Project

I. Project Background:

Olivehurst Public Utility District (OPUD) primary objective is to contract with a qualified vendor to provide an Advanced Metering Infrastructure (AMI) System for Water Utilities. This RFP will cover a system-wide fixed network implementation. OPUD wishes to obtain a system that provides the best long-term value over the system's lifetime, while providing hourly readings (minimum 24 readings per day for 20 years). For reliability and meter reading integrity, the Proposer shall be the sole source of the different components of the system deriving - if possible - from one manufacturer (water endpoints, contracting work, meter reading equipment and meter reading software).

The Proposer shall provide all hardware and software that together comprise the proposed AMI system (District will be responsible to work with their billing software for integration with selected vendor or AMI Integration). This includes meters, meter registers (in the case of retrofits), meter interface units, wire and wire connectors, data collection units, handheld programmers (if necessary), AMI control computers, a meter reading database or meter data management system (MDMS), and related software and interfaces.

The proposal must include all costs for network deployment and data collector unit installation, configuration, testing and training. All site preparation and installation costs must be reflected in the data collection unit pricing.

Respondents must provide at least five (5) AMI references using the proposed system and that have been installed or supported by the respondents for over two years. Include how long the system has been in operation, the total size of the utility, and how many endpoints are currently deployed.

This project is funded via the State of California (Department of Water Resources) through the Urban Community Drought Relief Grant. OPUD will pay awarded bidder within 150 days of completion of project or when funds are received from the State of California, whichever is sooner. No progress payments will be awarded unless otherwise notified by OPUD, however progress payments are recommended for submittal on a monthly basis.

About the Buyer

OPUD, or the "BUYER" is a special district that operates water, sewer, and parks located in Olivehurst, California within Yuba County. The District currently has roughly 8,015 service connections.

Administrator

OPUD General Manager or District Engineer will be the Contract Administrator for this project. For material specifications or question, please cc Robert Castillo via email at rcastillo@opud.org.

II. General Scope:

Each prospective contractor will submit a proposal for installing and providing full functioning AMI system that's outlined in this bid, which includes but is not be limited to:

Construction and installation of equipment as specified and listed above with a full turnkey system. The proposal will be **awarded to lowest responsible bidder** that meets all the qualifications and requirements listed in technical specifications.

We highly encourage prospective bidder to fully go through the documents, plans, and specifications for what is required on this project.

General Provisions/Requirements:

- This will be a prevailing wage project. Bidders cost shall include sales tax.
- Bidders submitting a proposal for this work shall first examine the site of the proposed work at the mandatory meeting. Mandatory site visit will be conducted **on Friday, February 16th, 2024 at 10 AM**. No make-up dates will be provided and all bidders must be present at the meeting to be considered for the job. We will start the meeting at the office at 1970 9th ave and proceed to move to the Plumas Water Treatment Plant (1074 Algodon Rd, Olivehurst, CA 95961) for location of tower installation.
- Contractor will be required to sign an OPUD standard contract (attached).
- Contractor qualifications: Company specializing in performing this type of work with a minimum of three (3) years' experience of similar project with product being supplied. Contractor will be required to supply contact information for a minimum of **FIVE (5)** AMI references using the proposed system that have been installed or supported by the bidder for over two years for those entities having previously contracted with contractor for similar projects.
- Client should be factory certified and be able to provide start up services and training to the owner/client without added expense of factory start up services not identified already on the bid list.
- *Products requiring electrical connection:* Listed and classified by Underwriters' laboratories (UL) suitable for the purpose specified and indicated.
- Contractor to furnish any required equipment not listed in the equipment lists provided above, transportation, and special or occasional services as required to effectively complete delivery as shown on the Drawings and described in this RFP and as specified and required by the manufacturer.
- Equipment not listed with these specifications or on drawings as furnished by the equipment supplier, but required for the complete purchase and delivery of the equipment shall be furnished by the contractor.
- Deliver all equipment in accordance with manufacturer's instructions and recommendations unless otherwise noted. If specified delivery is contrary to manufacturer's instructions, cease delivery of affected components or systems. Notify District Engineer and do not resume delivery without clear instructions.
- General: The bid awardee shall test equipment delivered in order to show that it complies with specified requirements. Testing shall be done (without added cost) in a manner approved by the District Engineer.
- Contractor shall, at his expense, make the AMI system operational and make test adjustments, and corrections, until it is shown to be in proper operation condition.

Equipment List and Location for Plumas Lake Water Treatment Plant and Olivehurst Public Utility District

The Plumas Lake WTP is located at 1074 Algodon Rd, Olivehurst, CA 95961. For equipment list see attached equipment list above and drawings attached. A representative from the OPUD will be available to inspect the layout of the equipment prior to the placement. This will be the site location and installation for 80' AMI tower and associated equipment.

The Olivehurst Public Utility District office is located at 1970 9th Ave., Olivehurst, CA 95961. The existing water tower is located onsite. Equipment for AMI system will be directly mounted to the tower.

III. Submission Requirements

- A. To be considered, submit one (1) SEALED hard copy of the original response, in 8 ½" by 11" format.
- B. Submission Deadline and Location: Proposals must be submitted to Swarnjit Boyal, Public Works Engineer, at the address listed below by 2:00PM, March 13, 2024. NO LATE BIDS WILL BE ACCEPTED.

Olivehurst Public Utility

1970 9th Ave.

Olivehurst, CA 95961

- C. Required Information: Please submit the following information in the order requested:
This section outlines the information that must be included in your proposal. Vendors should review this list to ensure that their proposals include all requested information prior to submission.
 - 1. The proposal must be signed and dated by a representative of the vendor's company who is authorized to negotiate contracts.
 - 2. Vendors submitting proposals should allow for normal mail or delivery time to ensure timely receipt of their Proposal.
 - 3. Failure to include any of the requested information within your Proposal may result in rejection/disqualification.
 - 4. No negotiations, decisions, or actions shall be executed by the proposer as a result of any discussions with any OPUD official, employee and/or consultant. Only those transactions provided in written form by OPUD may be considered binding. Also, OPUD will honor only written and signed transactions from proposers.
 - 5. The costs of preparation and delivery of the bid proposal are solely the responsibility of the Proposer. No payments shall be made by the buyer to cover costs incurred by any proposer in the preparation of or the submission of a proposal in response to this RFP or any other associated costs.
 - 6. The contents of each vendor's proposal, including technical specifications for hardware and software, and hardware and software maintenance fees, shall remain valid for duration of completion of project and per submittal from proposal due date.
 - 7. Please note that OPUD may choose not to purchase all the applications, or all the equipment listed in this Request for Proposal and reserves the right without any penalties upto 20% of the final bid total (excludes taxes and fees).
 - 8. OPUD will be awarding a contract to a single vendor for all core applications. Vendors are allowed to provide a proposal that includes subcontractors, but note, OPUD will only be

entering into a single agreement with one vendor acting as Prime. The Prime contractor will be responsible for the timeliness, quality, and deliverables provided by any subcontractors under the Prime contractor's agreement.

IV. Limitations

- A. This request does not commit OPUD to the award of a contract, or to pay any costs incurred in the preparation of a response to this request.
- B. OPUD may or may not require the prospective proposer to participate in negotiations and to submit additional technical information or other revisions to their proposal as may result from the negotiations.
- C. OPUD reserves the right to reject any or all proposals, to waive informalities, to request additional information and to award a contract deemed most advantageous for OPUD.
- D. OPUD reserves the right to award bids in whole or part when deemed to be in the best interest of the City. Bidder shall state on their bid form if their bid is “all or none”, otherwise it shall be considered as agreeing to this section.

V. Minimum Requirements of Proposer

- A. Proposals shall be considered only from firms normally engaged in performing the type of work specified within this Request for Proposal. In the determination of the evidence of responsibility and ability to perform the required services by the proposer, OPUD shall determine whether the evidence of responsibility and ability to perform is satisfactory. OPUD reserves the right to reject any or all proposals without cause.
- B. Previous experience in the performance of projects of a similar nature to ensure timely and efficient completion.
- C. Proposer shall have in-house Project Management and Technical Support staff to assist during project implementation and after project completion.
- D. The individual/firm warrants that he/she/they is fully qualified, with adequate personnel and experience to undertake the services required within a reasonable time.
- E. The proposer shall be an equal employment opportunity employer and shall adhere to any applicable local, state or federal affirmative action requirements.

VI. Criteria for Evaluation and Award

The successful Proposer will be selected based upon the best response offered to OPUD. Proposers may be requested to give an oral presentation after submission of responses should OPUD find it necessary to determine which the best is received.

Evaluation Criteria: Submitted proposals will be evaluated and scored based upon the following criteria (scoring sheets will be available to all bidders upon request, goal will be within 48 hours):

Criteria	Weight	Score out of 10
Price	50%	
Meets the System Qualifications	25%	
Local Service and Support	15%	
Quality of the RFP Response	10%	

Final Score (maximum amount = 10 pts)	100%	
---------------------------------------	-------------	--

VII. Incurred Expenses

OPUD is not responsible for any expenses which proposers may incur in the preparation and submittal of proposals requested by this RFP, including but not limited to, costs of travel, accommodations, interviews or presentation of proposals.

Technical Specifications

A. AMI System Overview

1. To protect and guarantee frequency interference levels over the 20-year life span of the system, FCC Part 24 or Part 90 approved primary use licensed spectrum is required.
2. Preference shall be given to systems using higher transmit power for signal reliability. Note, current leaser of tower resides with AT&T. Selected bidder must coordinate with AT&T in order to confirm no interference with any existing systems currently occupied within existing tower.
3. Describe the RF modulation used by the Endpoints (narrow band, spread spectrum, etc.). What are the advantages of this type of modulation? Is this modulation “off the shelf” or is it designed specifically for AMI applications? Can the transmissions be easily decoded by commercially available RF equipment?
4. Preference given to AMI system that is capable of being read through AMR if necessary.
5. Proposer must provide an official RF Propagation Study from a licensed RF engineer or engineering firm that displays exact location and height of all data collection equipment and coverage patterns.
 - a. The system as designed must provide for a meter read over a 4-day window for at least 98.5% of all meters in the service area.
 - b. The study must identify all required collection infrastructure required for system operation.
 - c. The study must identify any and all areas that are not covered in the propagation study. The Proposer shall provide and install any additional data collection equipment (receivers, collectors) required after endpoint deployment to achieve the coverage depicted in the RF propagation study. See attachments for OPUD Boundary and sphere of influence map.
6. What provisions does the Proposer provide to ensure that the Utility will not have to purchase additional collector infrastructure due to system underperformance?
7. AMI System must be capable of performing remote disconnection of water.
8. Preference shall be given to systems which require the least amount of collection infrastructure while still providing overlapping coverage for redundancy.
9. The system selected must have a 20-year operational life span. What warranties are offered on the Infrastructure? Please provide. Is this warranty nationally published, or is the warranty being provided on a case-by-case basis? Please provide clarification.
10. To avoid obsolescence and to allow for new technologies to be implemented, the infrastructure must utilize a configurable architecture that is capable of being updated

and/or reconfigured remotely. How does your system allow for new technologies? Please provide information.

11. OPUD wishes to maintain a Fixed Base Support and Extended Maintenance contract with the system Proposer.
12. Outline specifically what is covered by the proposed Fixed Base Support and Extended maintenance contract. Does the contract include extended maintenance on the data collection units and overall network?

B. Water Endpoints

Pit or Vault Applications

1. The endpoint shall be water submersible, capable of operating in 100% condensing humidity and provides operating temperature range of -22 F to 185 F (-30 C to 85C).
2. The endpoint antenna shall be designed to be installed through the industry standard 1¾" inch hole in a pit lid with no degradation of transmission range. The antenna will be capable of mounting to various thicknesses of pit lids from 1/4" to 1 ¾" inch.
3. Preference will be given to systems which can connect to meters without wire cutting or splicing.
4. Endpoints shall provide a 20-year warranty while delivering hourly readings (24 readings per day).
5. To avoid obsolescence and to allow for new technologies to be implemented, the endpoint must be capable of 2-way RF communication allowing firmware to be updated and settings to be reconfigured over the air.
6. AMI water endpoints must operate on FCC primary use licensed spectrum.
7. AMI water endpoints must be capable of being mounted through either plastic, iron or concrete meter pit lids.

C. Water Meters Information

5/8" – 1" Residential Meter Specifications

1. Type (SR II)

OPUD currently employs solid state, battery operated electromagnetic flow measurement system with a hermetically sealed, glass covered, electronic register with a programmable 9-digit display. This meter assembly is intended where measurement of both domestic and fire service water usage is desired.

2. Register

The register is an electronic device encapsulated in glass with 9 programmable digits utilizing a liquid crystal display (LCD). It will have indicators for flow direction, empty pipe, battery life and unit of measurement. The register must be hermetically sealed with a heat tempered glass cover and be tamper resistant. The register shall not be removable from the measuring sensor. The register shall utilize magnetic coupling technology to connect to a touch read, radio read or fixed base meter reading system in either an inside or pit set installation.

3. Certifications And Marking

All sizes of meter packages shall be UL (Underwriters Laboratories) Listed approved as being accepted for use on fire service lines and domestic water use. For such applications, the meter shall be identified indicating such acceptance.

1 ½” – 2” Residential Meter Specifications

1. Scope

These specifications set forth the cold water meters used in residential settings, including the following potential service applications and general considerations:

- Intended where a moderately wide flow range is anticipated
- Measurement of water usage for typical billing applications
- Measurement intended for typical commercial, residential and industrial applications
- Measurement of constant low to extended high flow usage

2. Performance

The meter assembly has performance capability of continuous operation up to the rated maximum flows as listed below without affecting long-term accuracy or causing any undue component wear. Maximum headloss through the meter / strainer assembly don't exceed those listed in the following table per meter size.

3. Operating Characteristics

METER SIZE	LOW FLOW (95% Min.)	OPERATING RANGE (98.5 - 101.5%)	PRESSURE LOSS (Not to Exceed)
1 1/2"	.75 GPM	2 to 150 GPM	6.7 PSI @ 150 GPM
2"	1.0 GPM	2.5 to 200 GPM	7.0 PSI @ 200 GPM
2" without strainer	1.0 GPM	2.5 to 200 GPM	4.4 PSI @ 200 GPM

4. Electronic Register

The meter's register is all electronic and does not contain any mechanical gearing to display flow and accurate totalization. The electronic register includes the following partial list of features:

- AMR resolution units fully programmable
- Large, easy-to-read LCD display
- 10-year battery life guarantee

5. Maximum Operation Pressure

The meter assembly shall operate properly without leakage, damage, or malfunction up to a maximum working pressure of 200 pounds per square inch (psig).

VIII.

IX. Proposal Format

Please include the following items in the order listed below:

- Cover Letter
- Table of Contents
 - Executive Summary
 - Company Information
 - Application Software and Hardware Information
 - Project Management, Implementation, and Conversion
 - Maintenance and Support
 - Training and Education
 - References
 - Cost Proposal

X. Proposal Terms and Conditions

A. Request for Proposal Format

Proposals must be made in strict accordance with the Request for Proposal format provided herein.

B. Bulletins and Addenda

Any bulletins or addenda to the Proposal specifications issued during the period between issuance of the RFP and receipt of proposals are to be considered covered in the Proposal and in awarding a contract they will become a part thereof. Receipt of bulletins or addenda shall be acknowledged by vendors in their proposal cover letter.

C. False or Misleading Statements

If, in our opinion, a proposal contains false or misleading statements or references that do not support a function, attribute, capability, or condition as contended by the vendor, the entire proposal shall be rejected.

D. Clarification of Proposal

We reserve the right to obtain clarification of any point in a vendor's proposal or to obtain additional information necessary to properly evaluate a particular proposal. Failure of a vendor to respond to such a request for additional information or clarification may result in rejection of the vendor's proposal.

E. Responsiveness

Proposals should respond to all requirements of this RFP to the maximum extent possible. Vendors are asked to clearly identify any limitations or exceptions to the requirements inherent in the proposed system. Alternative approaches will be given consideration, if the approach clearly offers us increased benefits.

F. Rejection of Proposal

Proposals that are not prepared in accordance with these instructions to vendors may be rejected/disqualified. If not rejected, the Olivehurst PUD may demand correction of any deficiency and accept the corrected Proposal upon compliance with these instructions to proposing vendors.

G. Bid Modifications

Any bidder may modify their bid by written or fax communications up to two days prior to the

closing time. The written or fax communication should not reveal the bid price as this will not be known until the sealed bid is opened.

H. Late Submissions

Regardless of cause, late qualifications will not be accepted and will automatically be disqualified from further consideration. It shall be the Vendor's sole risk to assure delivery at the designated office by the designated time. Late qualifications will not be opened and may be returned to the Vendor at the expense of the Vendor or destroyed if requested.

I. Acceptance of Proposals

The contents of the proposal of the successful bidder will become, at our option, a contractual obligation if a contract ensues. Failure of the successful bidder to accept this obligation may result in cancellation of the award.

Proposals submitted are offers only and the decision to accept or reject is a function of quality, reliability, capability, reputation, and expertise of the proposing vendors. Olivehurst PUD reserves the right to terminate the selection process at any time and to reject any or all proposals.

The Olivehurst PUD reserves the right to accept the Proposal that is, in its judgment, the best and most favorable to the interests of the Olivehurst PUD and to the public; to reject the low price Proposal; to accept any item of any Proposal; to reject any and all Proposals; and to waive irregularities and informalities in any Proposal submitted or in the Request for Proposal process, provided; however, the waiver of any prior defect or informality shall not be considered a waiver of any future or similar defect or informality. Proposing vendors should not rely upon or anticipate such waivers in submitting their Proposal.

SECTION II – ANTI-COLLUSION AFFIDAVIT

STATE OF: _____

COUNTY OF: _____

_____, being duly sworn deposes and says that:

1. He/She/They/Them is the _____ of _____ submitting the attached bid;
2. He is fully informed respecting the preparation and content of the attached bid and of all pertinent circumstances respecting such bid;
3. Such bid is genuine and is not collusive or sham bid;
4. Neither the said bidder, nor any of its officers, partners, owners, agents, representatives, employees or parties interested, including this affidavit, has in any way collude, conspired, connived or agreed, directly or indirectly, with any other bidder firm or person to submit or to refrain from bidding in connection with such contract, or has in any manner, directly or indirectly sought by agreement or collusion or communication or conference with any other bidder, firm or person to fix and overhead, profit, or cost element of the bid price of any other bidder to secure through collusion, conspiracy,

connivance or unlawful agreement any advantage against the Olivehurst PUD, or any person interested in the proposed contract; and

5. The price or prices quoted in the attached bit are fair and proper and are not contained by any collusion, conspiracy, connivance or unlawful agreement on the party of the bidder or any of its agents, representatives, owners, employees or parties, in interest, including this affiant.

(Contractor)

Subscribed and sworn to before me,

This _____ day of _____, 2024.

Notary Public _____

All communications regarding this project, including questions related to this Request for Proposal, shall be submitted in writing to Swarnjit Boyal, Public Works Engineer, by 2:00 p.m. on March 6, 2024 at: sboyal@opud.org & rcastillo@opud.org.

Sincerely,



Swarnjit Boyal, MS, Public Works Engineer
Olivehurst Public Utility District
530-743-8573 - Office
530-682-0736 - Cell
sboyal@opud.org - Email

PROPOSAL (BID)

OLIVEHURST PUBLIC UTILITY DISTRICT

Name of BIDDER _____

Business Address _____

The undersigned, as BIDDER, declares that the only persons or parties interested in this proposal as principals are those named herein; that this proposal is made without collusion with any other person, firm or corporation; that he has carefully examined the location of the work, the annexed proposal form of agreement, and the plans and specifications therein referred to; and he proposes and agrees, if this proposal is accepted, that he will contract with the owner in the form of the copy of the agreement annexed hereto, to provide all necessary machinery, tools, apparatus and other means of construction, and to do all the work and furnish all materials specified, in the manner and time prescribed, and according to the requirements of the owner as set forth, and that he will take in full payment therefore the following lump sum for the complete work, based on the attached hereto estimated quantities, to wit:

Contractor agrees to supply and/or to perform all the work described below and as instructed by the District Engineer in a good workman like manner for the following item

Line No.	Item	Quantity	Unit price	Total
AMI System				
Network Infrastructure, Setup, equipment, and Configuration				
1	M400B2 Basestation (or equivalent)	2		
2	Communication Backhaul	2		
3	M400B2 Basestation (or equivalent) Installation at Water Tower Site. Note no interference of radio frequency may occur with existing infrastructure in term of installation of basestation. Will need to coordinate with AT&T.	1		
4	M400B2 Basestation (or equivalent) Installation at New Tower Site - Includes New 80' Universal Aluminum Tower. Tower must be engineered and stamped by Structural Engineer.	1		
5	M400B2 Basestation (or equivalent) Certification	2		
6	520M Single Port SmartPoint Radio Transmitters (or equivalent) (PURCHASE ONLY , no installation required). Must be Sensus meter touch coupler compatible.	2,750		
7	520M Dual Port SmartPoint Radio Transmitters (or equivalent) (PURCHASE ONLY , no installation required). Must be Sensus meter touch coupler compatible.	825		
8	12-Month Performance Bond + Labor & Material Bond	1		
AMI Software Setup and Configuration				
9	Regional Network Interface (RNI) Software as a service (SaaS) Setup (or equivalent)	1		
10	Regional Network Interface (or equivalent) Training	1		
11	Sensus Analytics System (or equivalent) Setup	1		
12	Sensus Analytics (or equivalent) Basic Integration	1		
13	Sensus Analytics (or equivalent) Training	1		
14	Network Implementation/ Consumer portal system set-up (with current District Billing software in conjunction with proposed AMI System. District billing software upgrade is separate from this bid.)	1		
Two (2) Year Software Hosting and Support				
15	Annual Hosted RNI (or equivalent) Software-as-a-Service, Water Only (2 years) - (This bid will include first two years for this contract, known as initial start-up system integration and maintenance plug bug defusing, please send separate spreadsheet on cost for years 3-5).	1		
16	Annual Sensus Analytics Enhanced (or equivalent), Water Only (2 years) - (This bid will include first two years for this contract, known as initial start-up system integration and maintenance plus bug defusing, please send separate spreadsheet on cost for years 3-5).	1		
17	Annual Sensus Analytics (or equivalent) Text Messaging Fee (communication and relay to operators, first 2 years). -(This bid will include first two years for this contract, known as initial start-up system integration and maintenance plus bug defusing, please send separate spreadsheet on cost for years 3-5).	1		

18	Annual M400 Basestation (or equivalent) Extended Warranty (2 years). - (This bid will include first two years for this contract, known as initial start-up system integration and maintenance plus bug defusing, please send separate spreadsheet on cost for years 3-5).	2		
19	2 year Support - (This bid will include first two years for this contract, known as initial start-up system integration and maintenance, please send separate spreadsheet on cost for years 3-5).	1		
SUBTOTAL				

**Note: Owner to provide full turnkey system (includes any items not mentioned above)
 Owner must provide system and register compatible to Sensus SRII & OMNI meters currently in OPUDs system.**

The bidder shall set forth, in clearly legible figures, the bid price in the spaces provided in the following schedule:

	TOTAL BID AMOUNT	\$
Write out		
figures:		

The said quotations include the cost of insurance, sales tax, and every other item of expense direct or indirect incident to the contract.

This is not part of bid – rather breakdown for cost on software support that would be used for budgetary purposes down the road for bidder awarded (years 3 -5).

Line No.	Item	Quantity	Unit	Extended
Software Hosting and Support AMI System (years 3-5)				
Year Three Fees				
	Annual Hosted RNI (or equivalent) Software-as-a-Service, Water Only	1		
	Annual Sensus Analytics (or equivalent) Enhanced, Water Only	1		
	Annual Sensus Analytics (or equivalent) Text Messaging Fee (Optional)	1		
	Annual M400 Basestation (or equivalent) Extended Warranty	2		
	General Support	1		
			Year Three Total:	
Year Four Fees				
	Annual Hosted RNI (or equivalent) Software-as-a-Service, Water Only	1		
	Annual Sensus Analytics (or equivalent) Enhanced, Water Only	1		
	Annual Sensus Analytics (or equivalent) Text Messaging Fee (Optional)	1		
	Annual M400 Basestation (or equivalent) Extended Warranty	2		
	General Support	1		
			Year Four Total:	
Year Five Fees				
	Annual Hosted RNI (or equivalent) Software-as-a-Service, Water Only	1		
	Annual Sensus Analytics (or equivalent) Enhanced, Water Only	1		
	Annual Sensus Analytics (or equivalent) Text Messaging Fee (Optional)	1		
	Annual M400 Basestation (or equivalent) Extended Warranty	2		
	General Support	1		
			Year Five Total:	

LIST OF SUBCONTRACTORS

(Public Contract Code Section 4104)

In compliance with the provisions of Sections 4100 et seq. of the Government Code, the undersigned hereby designates below the names and locations of the place of business of each subcontractor who shall perform work on this contract in excess of one-half of one percent of the bid price. If the Contractor fails to specify a subcontractor for any portion of the work under the contract, he shall be deemed to have agreed to perform that work himself. Any change or substitution of subcontractors shall be accomplished in strict accordance with provisions of the Government Code.

Work to be Performed	Percent of Total Contract	Subcontractor's Name and Address	DIR #	CSLB Lic. #
1.				
2.				
3.				
4.				
5.				
6.				
7.				
8.				
9.				

NOTE: Additional numbered pages may be attached if needed.

Accompanying this proposal is (cashier's check) (certified check) (bidder's bond) (NOTE: Cross out those that do not apply) in the amount of _____dollars, being at least ten percent (10%) of the total amount bid. Licensed in accordance with the act providing for the Registration of Contractors

Respectfully submitted:

Signature

Address

Title

Date

License Number (if applicable)

Attest _____

LEGAL REGULATIONS AND RESPONSIBILITY TO THE PUBLIC

Laws to be Observed

The Contractor shall keep himself fully informed of all existing State and National laws and all municipal ordinances and regulations which in any manner affect those engaged or employed in the work, or the materials used in the work, or which in any way affect the conduct of the work, and of all such orders and decrees of bodies or tribunals having any jurisdiction or authority over the same.

Permits and Licenses

The Contractor shall procure all permits and licenses, pay all charges and fees, and give all notices necessary and incidental to the due and lawful prosecution of the work.

Existing Facilities

The Contractor shall exercise due care to avoid injury or damage to existing improvements or facilities, utilities, adjacent property, monuments, and roadside trees and shrubbery that are not to be removed or relocated. Existing mail boxes, signs, shrubbery, lawn, trees, markers, or any other facility or improvement which must be removed shall be replaced with the undamaged original or a new facility equal to the original at the Contractor's expense if damaged by reason of the Contractor's operations, to the satisfaction of the property owner.

Utilities

The plans and specifications identify certain existing utilities as known to the Engineer. It shall be the Contractor's responsibility to exactly locate those facilities and to protect those facilities from damage as a result of his operations. The attention of the Contractor is called to the fact that there may be other unlocated utilities within the project area. Prior to making any such excavation, Contractor shall attempt to identify the location of any such utilities. It shall be the duty of the Contractor to protect any such utilities from damage, provided however, the Contractor shall be compensated for any costs of locating any such additional utilities and shall be further compensated if damage shall occur to any utilities not located upon the plans and Specifications which damages are not caused in any part by the failure of the Contractor to exercise reasonable care and discretion in removing or relocating utility facilities not indicated in the plans and specifications. The Contractor shall not be assessed any liquidated damages for any delays in completion of the project necessarily and reasonably incurred when such delay was proximately caused by the failure of the public agency or the owner of the utility to provide for the removal or relocation of such utility facilities. The Contractor's specific attention is called to the fact that existing service laterals and appurtenances to those service laterals exist within the project area and such laterals are not shown on the plans and specifications but can be reasonably inferred from the presence of other visible facilities such as building, meters, junction boxes, adjacent to the site of construction. No additional compensation shall be paid for any damages or delay caused to such service lateral facilities and it is the Contractor's sole and

exclusive obligation to provide for the protection, replacement and repair of any such facilities. If the Contractor, while performing the contract, discovers any utility facilities not identified by the public agency, other than the existing service laterals or appurtenances, he shall immediately notify the Engineer.

New Facilities

Until the formal acceptance of the complete work by **Olivehurst Public Utility District**, the Contractor shall have the charge of and care thereof, and shall bear the risk of injury or damage to any part of the work by the action of the elements or others. The contractor, at Contractor's cost, shall rebuild, repair, restore and make good all such damages to any portion of the work occasioned by any of such causes before its acceptance.

Clear-Up

Prior to final acceptance and payment, the Contractor shall clean all roads or streets, borrow pits and all areas occupied by the forces during the construction of the improvement facilities, remove all refuse, excess material, temporary structures and equipment; and leave the entire project in a neat and presentable condition.

INSURANCE AND LIABILITY

GENERAL

The Contractor shall not commence any work until he obtains at his own expense, all required insurance from insurance companies acceptable to the Owner. Such insurance must have the approval of the Owner as to limit, form, and amount. The Contractor shall not permit any subcontractor to commence work on this project until the same insurance requirements, as applicable, have been complied with by such subcontractor. Nothing contained in these insurance requirements is to be construed as limiting the extent of the Contractor's responsibility for payment of damages resulting from his operations under this contract. As evidence of specified insurance coverage, the Owner may, in lieu of actual policies, accept certificates issued by the insurance carrier showing such policies in force for the specified period. Each policy or certificate shall bear an endorsement or statement waiving right of cancellation or reduction in coverage without 30 days notice in writing to be delivered by registered mail to the Owner. In case of the breach of any provisions of this article, the Owner, at his option, may take out and maintain at the expense of the Contractor, such insurance as the Owner may deem proper and may deduct the cost of such insurance from any moneys which may be due or become due the Contractor under this contract.

COMPREHENSIVE GENERAL LIABILITY INSURANCE

Before commencement of the work, the Contractor shall submit written evidence that he and all his subcontractors have obtained for the period of the contract, full comprehensive general liability insurance coverage. This coverage shall provide for both bodily injury and property damage. The bodily injury portion shall include coverage for injury, sickness, disease, death, arising directly or indirectly out of, or in connection with, the performance of the work under this contract, and shall provide for a limit of not less than \$1,000,000 for all damages arising out of bodily injury, sickness,

disease, or death of one person, and a total limit of \$1,000,000 for damages arising out of bodily injury, sickness, disease, or death of two or more persons in any one occurrence. The property damage portion shall include "broad form" coverage for a limit of not less than \$1,000,000 for all damages arising out of injury to or destruction of property of others arising directly or indirectly out of or in connection with the performance of work under this contract and in any one occurrence, including explosion, collapse, and underground exposure. Included in such insurance shall be contractual coverage sufficiently broad to insure that provision titled "Indemnity" hereinafter. The comprehensive general liability insurance shall include as additional named insured: the Owner, the Engineer and his consultants, and each of their officers, agents and employees.

WORKMEN'S COMPENSATION INSURANCE

Before the Contract between the Owner and the Contractor is entered into, the Contractor shall submit written evidence that he and all subcontractor's have obtained, for the period of the Contract, full Workmen's Compensation Insurance coverage for all persons whom they employ or may employ in carrying out the work under this contract. This insurance shall be in strict accordance with the requirements of the most current and applicable State Workmen's Compensation Insurance laws. The Contractor will be required to execute a certificate prior to performing the work of the Contract providing as follows: "I am aware of the provisions of Section 3700 of the Labor Code which requires every employer to be insured against liability for Workmen's Compensation or to undertake self insurance in accordance with the provisions of the Code and I will comply with such provisions before commencing the performance of the work of this Contract".

BUILDER'S RISK "ALL RISK" INSURANCE

Unless otherwise modified in the "Supplementary Conditions", the Contractor shall secure and maintain during the life of this Contract, Builder's Risk "All Risk" Insurance coverage for one hundred percent (100%) of the contract amount. Such insurance shall not exclude coverage for earthquake, landslide, flood, collapse, or loss due to the results of faulty workmanship, and shall provide for losses to be paid to the Contractor and the Owner as their interests appear. Such insurance may have a deductible clause not to exceed \$100,000 except that the deductible on earthquake may be in accordance with the underwriter's requirements, provided that it does not exceed five percent (5%) of the contract amount.

INSURANCE COVERAGE FOR SPECIAL CONDITIONS

When the construction is to be accomplished within a public or private right-of-way requiring special insurance coverage, the Contractor shall conform to the particular requirements and provide the required insurance. The Contractor shall include in his liability policy all endorsements that the said authority may require for the protection of its officers, agents, employees and interests.

INDEMNIFY

To the fullest extent permitted by law, the Contractor shall hold harmless, indemnify and defend the Owner, the Engineer and his consultants, and each of their officers and employees and agents,

from any and all liability, claims, losses, damages, or costs, including but not limited to attorney's fees, arising or alleged to arise from or during the performance of the work described herein caused by the act or omission of contract, any subcontractor, directly or indirectly employed by them, or anyone for whose acts any of them may be liable, regardless of whether or not caused in part by the party indemnified hereunder, or by the negligence or omission of the party indemnified herein.

NO PERSONAL LIABILITY OF PUBLIC OFFICIALS

In carrying out all the provisions hereof in exercising any authority granted by the contract, there will be no personal liability upon any public official.

Substitution of Security

In lieu of the 5% retention in payment as set forth hereinafter, the contractor may, upon request to the District, substitute in lieu thereof securities in form and content acceptable to the District, pursuant to the provisions of Section 4590 of the Government Code of the State of California. All costs and expense of any escrow or trustee shall be the responsibility of the contractor.

RESOLUTION OF CLAIMS

1. Public Contract Code Section 9204 specifies provisions on resolving contract claims of any size, and Public Contract Code Section 201014, et seq., specifies required provisions on resolving contract claims less than \$375,000. Those statutes constitute a part of this Contract. In the event any other Contract provision violates such statutes, the applicable statute controls.
2. Public Contract Code Section 9204 provides:
 - a. For the purposes of this section, "Claim" means a separate demand by Contractor for (1) a time extension, (2) payment or money or damages arising from Work done by or on behalf of Contractor arising under the Contract Documents and payment of which is not otherwise expressly provided for or the Claimant is not otherwise entitled to, or (3) an amount the payment of which is disputed by Owner.
 - b. Procedure:
 - 1) Upon receipt of a Claim the Owner shall conduct a reasonable review of the Claim and within 45 days, or if Owner's governing body must approve Owner's response to the Claim and the governing body has not met within the 45 days then within three (3) days of the governing body's meeting, shall provide Contractor with a written statement identifying what portion of the claim is disputed and what portion is undisputed. Should Owner take no action on the Claim within 45 days of submission, it shall be deemed denied.
 - 2) If the Contractor disputes Owner's response to its Claim, including a failure to respond, it may submit via registered mail or certified mail,

return receipt requested, a written demand for an informal conference to meet and confer for settlement of the issues in dispute. Owner shall schedule such a meet and confer conference within 30 days for settlement of the dispute. Within ten (10) days of the meet and confer conference Owner shall provide Contractor with a written statement identifying the portion of the Claim that remains in dispute and the portion that is undisputed. If the Contractor disputes Owner's statement it shall inform Owner and they shall mutually agree to a mediator within 10 business days of the written statement.

- 3) Owner shall pay the undisputed portions of the Claim within 60 days of the issuance of a written statement identifying an undisputed portion.
- 4) Any disputed portion of the Claim, as identified by the Contractor in writing, shall be submitted to nonbinding mediation, with the Owner and the claimant sharing the associated costs equally. The Owner and claimant shall mutually agree to a mediator within 10 business days after the disputed portion of the claim has been identified in writing. If the parties cannot agree upon a mediator, each party shall select a mediator and those mediators shall select a qualified neutral third party to mediate with regard to the disputed portion of the claim. Each party shall bear the fees and costs charged by its respective mediator in connection with the selection of the neutral mediator. If mediation is unsuccessful, the parts of the Claim remaining in dispute shall be subject to applicable procedures outside this section.
- 5) For claims under \$375,000, unless the parties agree otherwise in writing, mediation pursuant to these provisions shall excuse the mediation obligation under Public Contracting Code section 20104.4(a).
- 6) The parties may mutually agree, in writing, to waive the mediation requirements of this subsection and proceed to the commencement of a civil action or binding arbitration, as applicable.
- 7) Failure by the Owner to respond to a Claim from a Contractor within the time periods described in this subdivision or to otherwise meet the time requirements of this section shall result in the claim being deemed rejected in its entirety. A Claim that is denied by reason of the public entity's failure to have responded to a Claim, or its failure to otherwise meet the time requirements of this section, shall not constitute an adverse finding with regard to the merits of the Claim or the responsibility or qualifications of the claimant.
- 8) Amounts not paid in a timely manner as required by this section shall bear interest at 7 percent per annum.
- 9) If a Subcontractor or a lower tier subcontractor lacks legal standing to assert a claim against Owner because privity of contract does not exist, the Contractor may present to the Owner a claim on behalf of a Subcontractor or lower tier subcontractor. A Subcontractor may request in writing, either on his or her own behalf or on behalf of a lower tier subcontractor, that the Contractor present a claim for work which was performed by the Subcontractor or by a lower tier subcontractor on behalf

of the Subcontractor. The Subcontractor requesting that the Claim be presented to the public entity shall furnish reasonable documentation to support the claim. Within 45 days of receipt of this written request, the Contractor shall notify the Subcontractor in writing as to whether the Contractor presented the claim to the Owner and, if the original Contractor did not present the claim, provide the Subcontractor with a statement of the reasons for not having done so.

- 10) Nothing in this section shall impose liability upon an Owner that makes loans or grants available through a competitive application process, for the failure of an awardee to meet its contractual obligations.
 - 11) This section shall remain in effect only until January 1, 2020, and as of that date is repealed, unless a later enacted statute, that is enacted before January 1, 2020, deletes or extends that date.
3. To the extent applicable, Public Contract Code Section 20104, et seq., provide.
- a. For the purposes of this section, "Claim" means a separate demand by Contractor of \$375,000 or less for (1) a time extension, (2) payment or money or damages arising from Work done by or on behalf of Contractor arising under the Contract Documents and payment of which is not otherwise expressly provided for or the Claimant is not otherwise entitled to, or (3) an amount the payment of which is disputed by Owner. Separate Contractor Claims that together total more than \$375,000 do not qualify as a "separate demand of \$375,000 or less," as referenced above, and are not subject to this section.
 - b. Caution. This section does not apply to tort claims, and nothing in this section is intended nor shall be construed to change the time periods for filing tort claims or actions specified by Chapter 1 and Chapter 2 of Part 3 of Division 3.6 of Title 1 of the Government Code.
 - c. Procedure:
 - 1) The Claim must be in writing, submitted in compliance with all requirements set forth in this document, without limitation, the time prescribed by and including the documents necessary to substantiate the Claim. Nothing in this section is intended to extend the time limit or supersede notice requirements for the filing of claims as set forth elsewhere in the Contract Documents.
 - 2) For Claims of fifty thousand dollars (\$50,000) or less, Owner shall respond in writing within forty-five (45) days of receipt of the Claim, or Owner may request in writing within thirty (30) days of receipt of the Claim, any additional documentation supporting the Claim or relating to any defenses or claims Owner may have against Claimant. If additional information is thereafter required, it shall be requested and provided in accordance with this section upon mutual agreement of Owner and Claimant. Owner's written response to the Claim, as further documented, shall be submitted to Claimant within fifteen (15) days after receipt of further documentation or within a period of time no greater than taken by Claimant in producing the additional information, whichever is greater.

- 3) For Claims over Fifty Thousand Dollars (\$50,000) and less than or equal to \$375,000: Owner shall respond in writing within sixty (60) days of receipt of the Claim, or Owner may request in writing within thirty (30) days of receipt of the Claim, any additional documentation supporting the Claim or relating to any defenses or claims Owner may have against Claimant. If additional information is thereafter required, it shall be requested and provided in accordance with this section, upon mutual agreement of Owner and Claimant; Owner's written response to the Claim, as further documented, shall be submitted to Claimant within thirty (30) days after receipt of further documentation or within a period of time no greater than taken by Claimant in producing the additional information, whichever is greater.
- 4) Meet and Confer: If Claimant disputes Owner's written response, or Owner fails to respond within the time prescribed above, Claimant shall notify Owner, in writing, either within fifteen (15) days of receipt of Owner's response or within fifteen (15) days of Owner's failure to timely respond, and demand an informal conference to meet and confer for settlement of the issues in dispute. Upon demand Owner will schedule a meet and confer conference within thirty (30) days for settlement of the dispute.
- 5) Following the meet and confer conference, if the Claim or any portion remains in dispute, Claimant may file a claim as provided in Chapter 1 (commencing with Section 900) and Chapter 2 (commencing with Section 910) of Part 3 of Division 3.6 of Title 1 of the Government Code. For purposes of those provisions, the running of the period of time within which a claim must be filed shall be tolled from the time Claimant submits its written claim as set forth herein, until the time that Claim is denied as a result of the meet and confer process, including any period of time utilized by the meet and confer process.

STANDARD CONTRACT (AGREEMENT)

OLIVEHURST PUBLIC UTILITY DISTRICT

THIS AGREEMENT, made this _____ day of _____, _____, by
and between **Olivehurst Public Utility District** (hereinafter called "OWNER"),
(Name of Owner), (an Individual)
and _____ doing business as
(Name of General Contractor)
(an individual,) or (a partnership,) or (a corporation) hereinafter called "CONTRACTOR".
The aforementioned parties agree as follows:

I

The Contractor agrees to furnish for the total sum of (includes bid additives)
_____ Dollars,
all labor, materials, tools and equipment and perform all the work required to construct and
complete in a good workmanlike manner all improvements and work mentioned, described,
delineated, shown and referred to in the plans and specifications, general conditions and special
conditions Including any bid additives. Plans and specifications are included within this contract by
reference as if set forth in full.

II

Contractor agrees to furnish all necessary tools, equipment, supplies, labor and materials
required for the performance and completion of said work and improvement, all to the satisfaction
of Owner, and subject to the requirements of the Engineer.

Owner hereby fixes the time for the commencement of said work and improvements under this
Agreement to be within 20 calendar days, and such work and improvements shall be prosecuted

with diligence from day to day thereafter for a completion date which includes all equipment, inspections, and full turnkey system by 11/15/2024. It is agreed and stipulated between Owner and the Contractor that damage will be sustained by the Owner from any delays in the performance of this contract, and it is currently contemplated by the parties and estimated by the parties, that it will be impracticable and extremely difficult to fully ascertain and determine the actual damage which the Olivehurst Public Utility District will sustain by such delays. The parties agree that they shall be deemed to have jointly studied and attempted to estimate the damages suffered by the Olivehurst Public Utility District by such a delay under these circumstances and to agree and stipulate by this contract the sum of \$100 Dollars per day for each and every day's delay beyond the time prescribed to complete the work which has been agreed to by the parties as a fair estimate of the damage to be suffered by the Olivehurst Public Utility District from and as a direct result of such delay.

Contractor agrees to provide proof to Olivehurst Public Utility District of insurance naming Olivehurst Public Utility District and Engineer and employees as named insured in amounts of no less than coverage for \$1,000,000 per person and \$1,000,000 per occurrence and property damage up to \$1,000,000 and a standard broad form comprehensive and automobile liability policy form. Contractor further agrees to insure that every subcontractor employed by Contractor shall have insurance of equal character and limits of \$1,000,000 per person and \$1,000,000 per each occurrence and property damage up to \$1,000,000 per each occurrence and to provide certificates to Olivehurst Public Utility District of such insurance prior to allowing such subcontractor to commence work upon the project.

Contractor further agrees to provide prior to commencement of work and to require every subcontractor to provide prior to the commencement of work, a certificate pursuant to Labor Code Section 3700 et.seq. which will state as follows:

"I am aware of the provisions of Section 3700 of the Labor Code which requires every employer to be insured against liability for Workmen's Compensation or to undertake self-insurance in accordance with the provisions of the code, and I will comply with such provisions before commencing the performance of the work of this Contract."

Contractor agrees to comply with each and every provision of the Section 1770 through Section 1780 of the Labor Code relating to prevailing wages. The Contractor shall be required to forfeit to Owner the amount of Fifty Dollars (\$50) for each calendar day, or portion thereof, for each workman paid less than the prevailing wages as determined for the work done herein. The difference between prevailing wage rate and the amounts paid to each workman for each calendar day or portion thereof for which each workman was paid less than the prevailing wage rate shall be paid to each workman by the Contractor.

Contractor further agrees to comply with each and every provision of Section 1777.5 of the labor Code of the State of California relating to apprenticeship standards and the employment of apprentices upon project and to comply with each and every provision of Section 1810 through 1815 of the Labor Code relating to the employment of workmen in excess of eight (8) hours in violation of the Labor Code.

Is the contractor registered with the Department of Industrial Relations in accordance with California Labor Code section 1725.5 et seq.*? _____

*As of July 1, 2014, the District cannot enter into a Public Works Contract with a contractor that is not registered with the Department of Industrial Relations in accordance with California Labor Code section 1725.5 et seq..

III

Contractor agrees to pay to Olivehurst Public Utility District, or to make at its' own expense all repairs, replacements or payments necessitated by defects in materials or workmanship supplied

under the terms of this contract which exist within one (1) year after the date of final acceptance of the work. This Agreement shall cover defects which shall be in existence during such one (1) year period. This Agreement shall apply to all defects which exist in the first year whether or not discovered within the first year. The Contractor shall be fully responsible for all direct and indirect damages and expenses to Olivehurst Public Utility District proximately caused by such defects in materials or workmanship, including defects and materials which bear a guarantee or warranty in writing or by law for a period longer than one (1) year, Contractor hereby stipulates and agrees that such guarantees shall be inure for the benefit of Olivehurst Public Utility District for such longer periods. The effective date for the start of the guarantee or warranty for equipment qualifying as substantially complete, shall be upon the time Olivehurst Public Utility District takes possession and operation of equipment or materials. In any case the warranty period described in this contract shall not limit the applicable statute of limitations for breach of a written contract and legal provisions for the District. Certain items in the project specifications may have specific warranty periods and provisions specified and the longer of the specified or contractual warranty period shall prevail.

The Contractor also agrees to hold the Olivehurst Public Utility District harmless from liability, both direct and indirect, of any kind arising from damage due to such defects. The Contractor shall make all repairs, replacements, or payments promptly upon receipt of written order for the same from the Olivehurst Public Utility District. If Contractor fails to make the repairs or replacements or payments within the time specified by Owner, then, subject to the sole discretion of Olivehurst Public Utility District, District may do the work in any manner it sees fit, and the Contractor and his surety shall be liable for the cost thereof, including all costs of engineers or consultants required to do said work and all cost related to the expedition of said work. Any

additional requirements for the project relative to the collection for defective work after final acceptance are provided for hereafter in this Agreement.

Contractor shall provide a faithful performance bond in the amount of one hundred percent (100%) of the contract price, and a labor and materials bond in the amount of one hundred percent (100%) of the contract price on the attached forms. Said bonds shall be issued by an admitted surety insurer within the State of California and will be supported by the information and certifications required under California Code of Civil Procedure Section 995.660.

IV

The complete Contract consists of the following documents to wit: The notice to Contractors, the General Provisions, the Technical Provisions, the Proposal (Bid), the form of Contract (Agreement), the Labor and Material Bond, the Performance Bond, all specifications and drawings, and all modifications made or incorporated in any of those documents. All of the above documents are intended to be complementary, so that any work called for in one and not mentioned in the other is to be executed the same as if mentioned in all of said documents. Similarly, any contract provision appearing in one shall be binding as if it appeared in all said documents.

V

Contractor shall be financially responsible for claims (including claims of OSHA or other agency with jurisdiction over the job), liens, or stop notices, including preliminary notices that are filed on the job. In lieu of retention of payment by the DISTRICT, CONTRACTOR may elect to deposit certain securities equivalent to the amount to be withheld into a District approved escrow account.

CONTRACTOR shall be solely responsible for all construction under this contract, including the technique, sequences, procedures, and means, and for coordination of all work. CONTRACTOR shall supervise and direct the work to the best of CONTRACTOR'S ability, and give all attention necessary for such proper supervision and direction. Contractor shall have full control over the site and shall be responsible to take all required steps, and implement all required procedures, required for the safety of employees and the public. Contractor shall be aware of and obey all OSHA regulations pursuant to the work he is engaged in for this project.

CONTRACTOR has the duty of providing for and overseeing all safety orders, precautions, and programs necessary to the reasonable safety of the work. In this connection, CONTRACTOR shall take reasonable precautions for the safety of all work employees and all other persons that the work might affect, all work and materials incorporated in the project, and all property improvements on the construction site and adjacent to the site, and comply with all applicable laws, ordinances, rules, regulations, and orders. Contractors' cost of work includes the costs of all required safety measures including sheeting, shoring and trenching for the protection of life and limb.

VI

PAYMENT TO BIDDER: This project is funded via The State of California (Department of Water Resources) through the Urban Community Drought Relief Grant. OPUD will pay awarded bidder within 150 days of completion of project or when funds are received from the State of California, whichever is sooner.

Owner:

_____	_____
Signature	Name
_____	_____
Title	Date

Attest:

Contractor:

_____	_____
Signature	Name
_____	_____
Title	Date

Attest:

PERFORMANCE BOND

KNOW ALL MEN BY THESE PRESENTS, that we, _____
_____ hereinafter
called Principal, and _____
_____ hereinafter
called Surety, are held and firmly bound unto _____
_____ hereinafter called the Owner, in
the sum of _____ dollars (\$ _____) in
lawful money, for the payment of which sum well and truly to be made, we bind ourselves, or heirs,
executors, administrators and successors, jointly and severally, firmly by these presents.

THE CONDITION OF THIS OBLIGATION is such that whereas the Principal entered into a
certain Contract, hereto attached, with the OWNER, dated _____, 201____, for
the construction of:

OLIVEHURST PUBLIC UTILITY DISTRICT

NOW, THEREFORE, if the Principal shall well, truly and faithfully perform its duties, all the
undertakings, covenants, terms, conditions and agreements of said Contract during the original term
thereof and any extension thereof that may be granted by the OWNER, with or without notice to the
Surety, and during the life of any guaranty required under the Contract, and shall also well
and truly perform and fulfill all the undertakings, covenants, terms, conditions, and agreements of
any and all modifications of said Contract that may thereafter be made, except that no change
will be made which increases the total contract amount more than twenty percent (20%) in excess of
the original Contract amount without notice to the Surety, then this obligation shall be void,
otherwise the same shall remain in full force and virtue.

Surety hereby expressly waives written notice of any changes, alterations, modifications of the
contract entered into between Principal and OWNER and agrees and stipulates that such changes
and modification shall be treated as part of such Contract and Surety shall be bound thereby except
that Surety will not be bound to any changes or alterations which increase the total contract amount

more than twenty percent (20%) in excess of the original contract amount without written notice to Surety.

IN WITNESS THEREOF, the above bounded parties have executed this instrument under their several seals this _____ day of _____, 20____, the name and corporate seal of each corporate party being hereto affixed and those presents duly signed by its undersigned representative pursuant to authority of its governing body.

IN PRESENCE OF:

Principal:

_____ Signature	_____ Name
_____ Title	_____ Date
Attest:	

Principal:

_____ Signature	_____ Name
_____ Title	_____ Date
Attest:	

Surety:

_____ Signature	_____ Name
_____ Title	_____ Date
Attest:	

The rate of premium on this bond is _____ per thousand.

Total amount of premium charges _____ Dollars (\$ _____)

IMPORTANT: Surety companies executing BONDS must appear on the Treasury Department's most current list (Circular 570 as amended) and must be authorized to transact business in the state where the PROJECT is located.

LABOR AND MATERIAL BOND

KNOW ALL MEN BY THESE PRESENTS, that, _____

has awarded to _____

_____ hereinafter
designated as the CONTRACTOR, a Contract for the work described as follows:

OLIVEHURST PUBLIC UTILITY DISTRICT

and, WHEREAS, said CONTRACTOR is required to furnish a bond in connection with said Contract, providing that if said CONTRACTOR, or any of his or its SUB-CONTRACTORS, shall fail to pay for any materials, provisions, provender, or other supplies or teams used in, upon, for, or about the performance of the work contracted to be done, or for any work or labor done thereon of any kind, that the Surety on this bond will pay the same.

NOW, THEREFORE, we, _____

the undersigned contractor, as Principal, and _____

COMPANY, a corporation organized and existing under the laws of the State of _____,

and duly authorized to transact business under the laws of the State of California, as Surety, are held and firmly bound unto _____

in the sum of _____ Dollars (\$ _____),

said sum being not less than the estimated amount payable by the said _____

_____ under

the terms of the Contract, for which payment well and truly to be made, we bind ourselves, our heirs, executors and administrators, successors and assign, jointly and severally, firmly by these presents. THE CONDITION OF THIS BOND IS SUCH, that if the above bonded Principal or his subcontractors fail to pay any of the persons named in Section 3181 of the Civil Code of the State of California, or amounts due under the Unemployment Insurance Code with respect to work or labor performed by any such claimant, for any amounts required to be deducted, withheld, and paid over to the Franchise Tax Board from wages of employees of the Contractor or his subcontractor pursuant to Section 18806 of the Revenue and Taxation Code, with respect to such work and labor,

the Surety will pay the same, in an amount not exceeding the amount specified in this bond, and also, in case suit is brought upon this bond, a reasonable attorney's fee, to be fixed by the Court. This bond shall insure to the benefit of any and all persons, companies or corporations entitled to file claims under Section 3181 of the Civil Code of the State of California, so as to give a right of action to them or their assigns in any suit brought upon this bond.

Should the condition of this bond be fully performed, then obligation shall become null and void, otherwise it shall be and remain in full force, virtue and effect.

And the said Surety, for value received, hereby stipulates and agrees that no change, extension of time, alteration or addition to the terms of said contract or the Specifications accompanying the same shall in any manner affect its obligations on this bond, and it does hereby waive notice of any such change, extension, alteration or addition.

SIGNED, sealed with our seals, and dated this _____ day of _____, 20____
(To be signed by Principal and Surety and acknowledgments and Notaries Seal attached)

Principal:

_____	_____
Signature	Name
_____	_____
Title	Date
Attest:	

Attorney-in-Fact:

_____	_____
Signature	Name
_____	_____
Title	Date
Attest:	

Surety:

_____	_____
Signature	Name

Title

Attest:

Date

ATTACHMENT A – EXISTING TOWER SITE INFORMATION

Existing Tower Aerial

Legend

- 1970 9th Ave
- Olivehurst Community Park
- Olivehurst Public Utility
- OPUD Pool

9th Ave

9th Ave

9th Ave

9th Ave

9th Ave

9th Ave

1970 9th Ave

Tower location (130' Tower)

Fenced Area

AT&T Building

Back-up Generator

Olivehurst Public Utility

Olivehurst Community Park

OPUD Pool

Powerline Rd

Powerline Rd



200 ft



Aerial view of Existing Tower Location (Facing NorthWest)



Aerial view of Existing Tower Location (Facing West)



Close Up of Cable Configuration on Tower Leg

**ATTACHMENT B – NEW PROPOSED SITE TOWER
INFORMATION**

1074 Algodon Rd - Plumas Water Treatment Plant

Proposed Tower Site

3 Filters currently being installed. project will be near completion when tower installation begins.

Relative Location of 6'X8' AMI PAD for (N) Tower. See location on site plan below.

Area currently being used for storage of filter project.

Legend

Algodon Rd

Algodon Rd

Algodon Rd

Algodon Rd

Algodon Rd

Algodon Rd

EventsRemembered4U

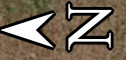

300 ft

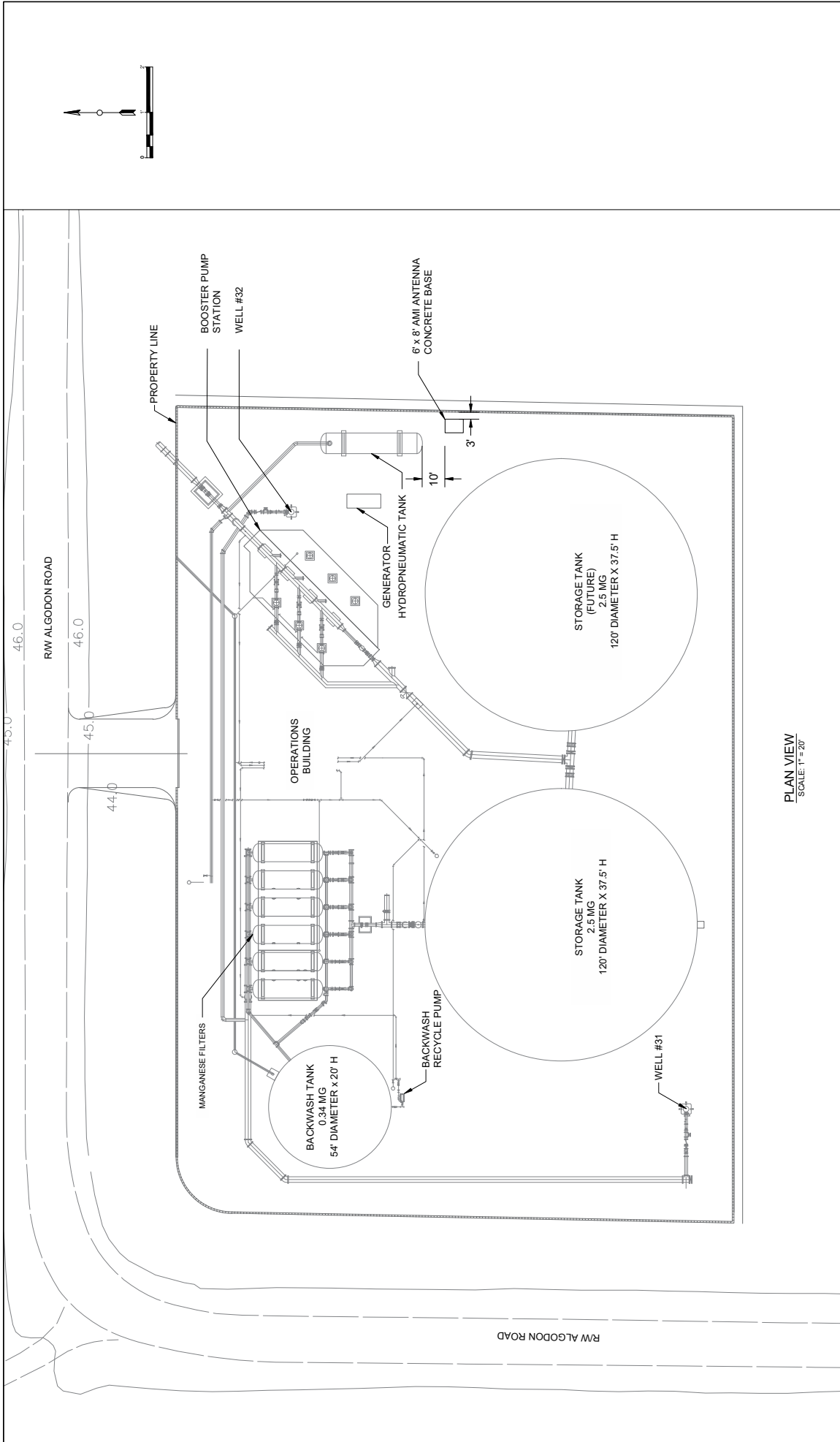

PLAN VIEW
SCALE: 1" = 20'

CONSULTANT: AFFINITY ENGINEERING 3433 Mauld Grass Court, Rancho Cordova, CA, 95670 www.affinity-engineering.com		NO.	REVISION DESCRIPTION	BY	DATE	CLIENT: Olivehurst Public Utility District 1970 9th Avenue, Olivehurst, CA 95961	PROJECT: PLUMAS LAKE WATER PLANT ADVANCED METERING INFRASTRUCTURE	SCALE: AS SHOWN ATTENTION LINE IS 2" AT FULL SIZE (SCALE ACCORDINGLY)	SHEET TITLE: AMI TOWER LOCATION	SHEET NAME: C3
									SHEET NUMBER: 1 OF 1 7/5/23	



View of location of placement of New 80' Tower, facing East (ignore portable generator, will be removed)



View of relative location of placement of 80' Tower (View facing North)

FREESTANDING ALUMINUM TOWER

MODEL #HD 12-80

TOTAL WEIGHT: 351 LBS.

WIND LOADING:
11.91 Sq. Ft.

Contact Universal Towers to confirm
geographical location of your tower and
all wind load implications

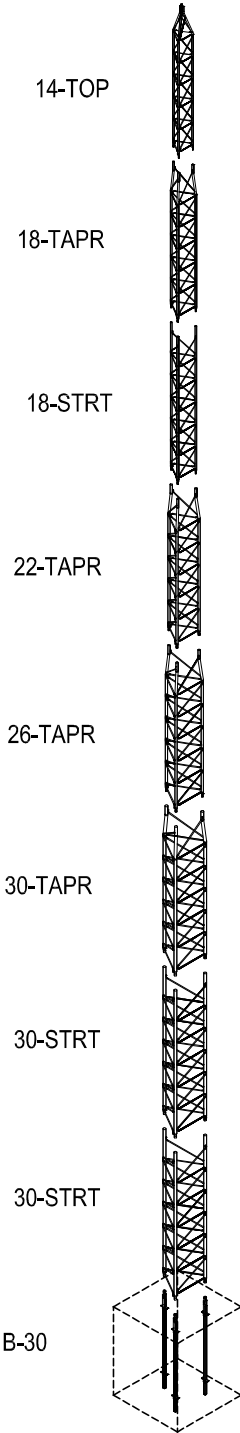
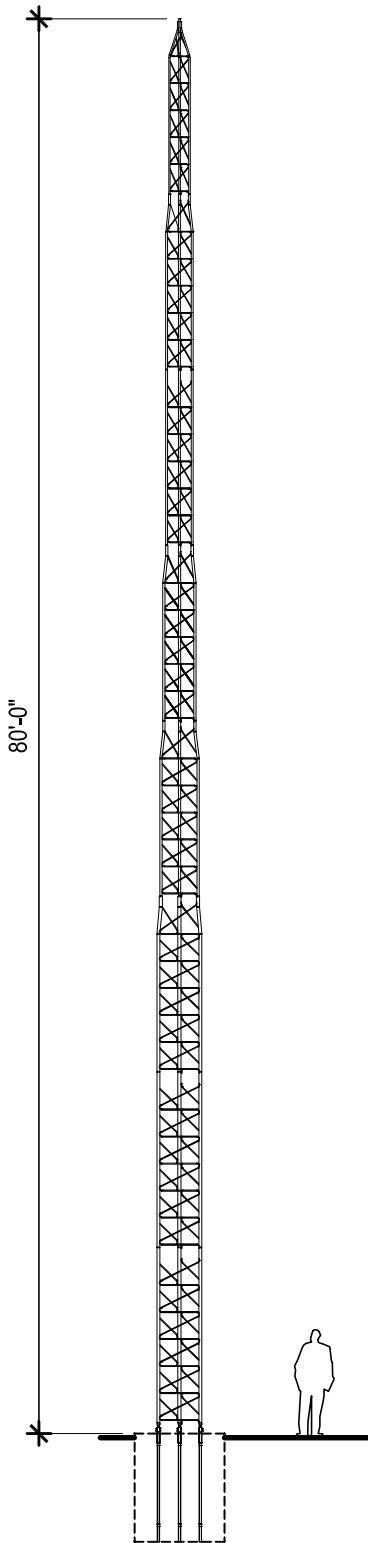

WARRANTY

UNIVERSAL TOWERS ARE WARRANTED AGAINST DEFECTIVE MATERIAL OR WORKMANSHIP AND ARE SUBJECT TO REPAIR OR TO MATERIAL REPLACEMENT ONLY IF FAILURE RESULTS FROM THESE FACTORS WITHIN ONE YEAR FROM PURCHASE BY USER. THIS WARRANTY DOES NOT EXTEND TO ANY OF OUR PRODUCTS WHICH HAVE BEEN SUBJECTED TO MISUSE, NEGLIGENCE, ACCIDENT, IMPROPER INSTALLATION OR APPLICATION, NOR SHALL IT EXTEND TO UNITS WHICH HAVE BEEN REPAIRED OR SUBSTANTIALLY ALTERED OUTSIDE OF OUR FACTORY. THIS WARRANTY IS IN LIEU OF ALL OTHER WARRANTIES EXPRESSED OR IMPLIED.

ELEVATION

SCALE: 3/32"=1'=0"

2

ISOMETRIC

SCALE: N.T.S.

1

ALUMINUM TOWER



UNIVERSAL TOWERS
A DIVISION OF
UNIVERSAL MANUFACTURING CORP.
43900 GROESBECK HWY.
CLINTON TOWNSHIP, MI 48036
PH: (586) 463-2560
FAX: (586) 463-2964

JOB NO.:

COMPONENT:

HD 12-80

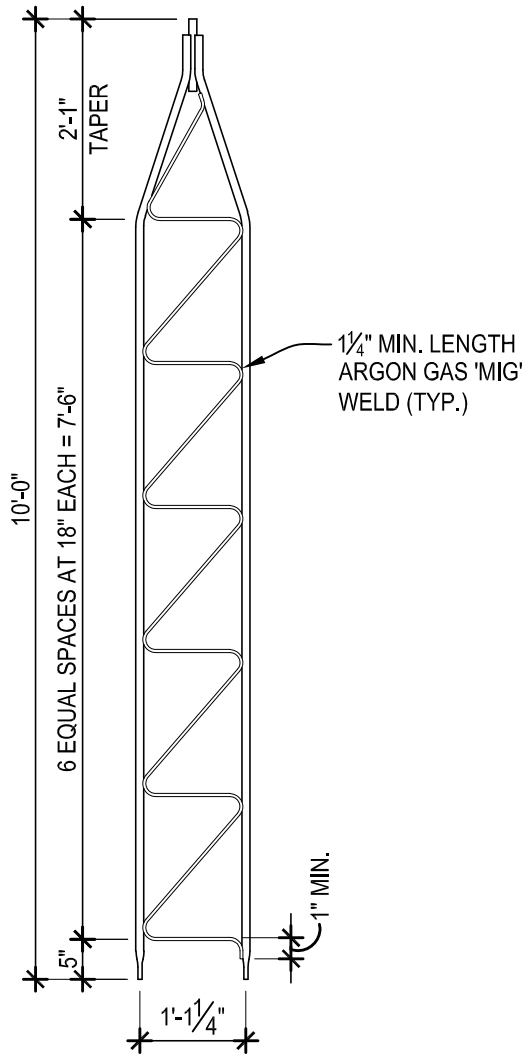

ELEVATION

SCALE: 1/2"=1'-0"

2

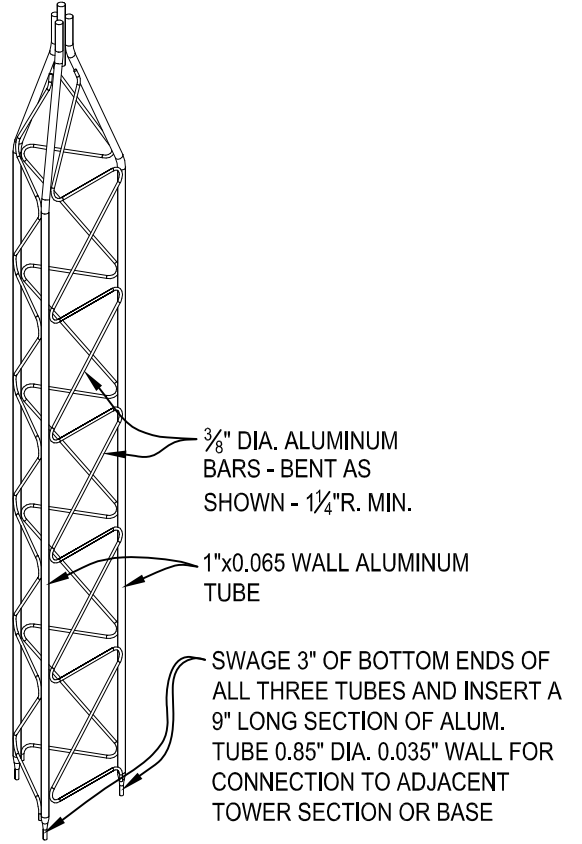

ISOMETRIC

SCALE: N.T.S.

3

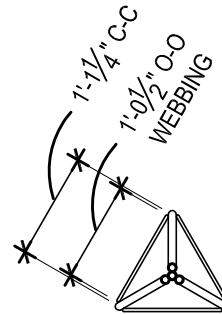

PLAN VIEW

SCALE: 1/2"=1'-0"

1

TOP SECTION



UNIVERSAL TOWERS
 A DIVISION OF
 UNIVERSAL MANUFACTURING CORP.
 43900 GROESBECK HWY.
 CLINTON TOWNSHIP, MI 48036
 PH: (586) 463-2560
 FAX: (586) 463-2964

JOB NO.:

COMPONENT:

14-TOP

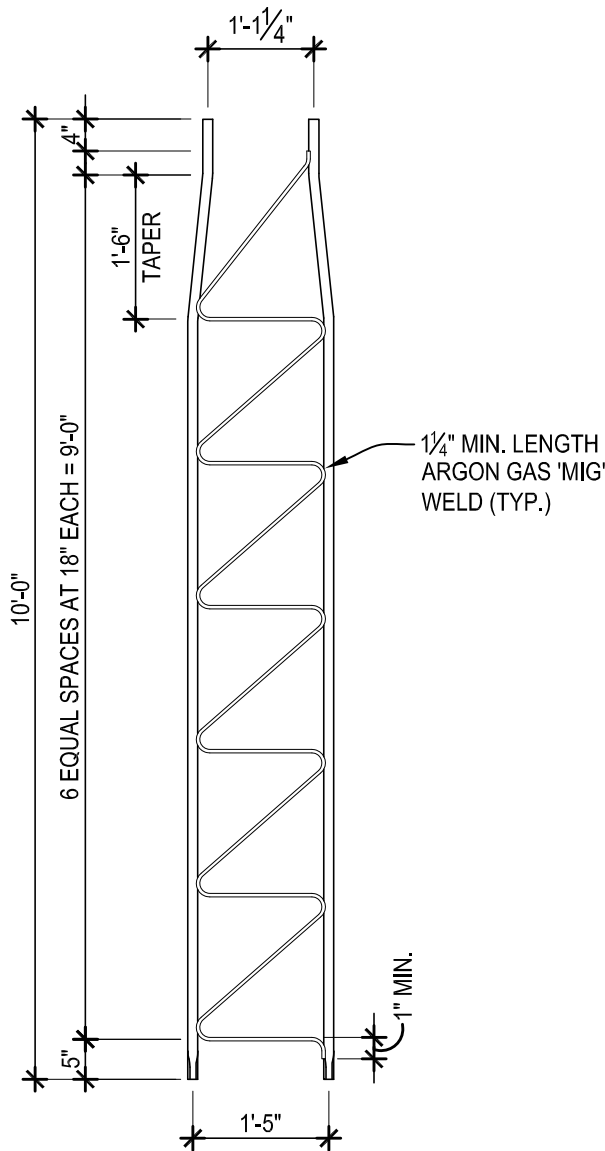

ELEVATION 2
SCALE: 1/2"=1'-0"

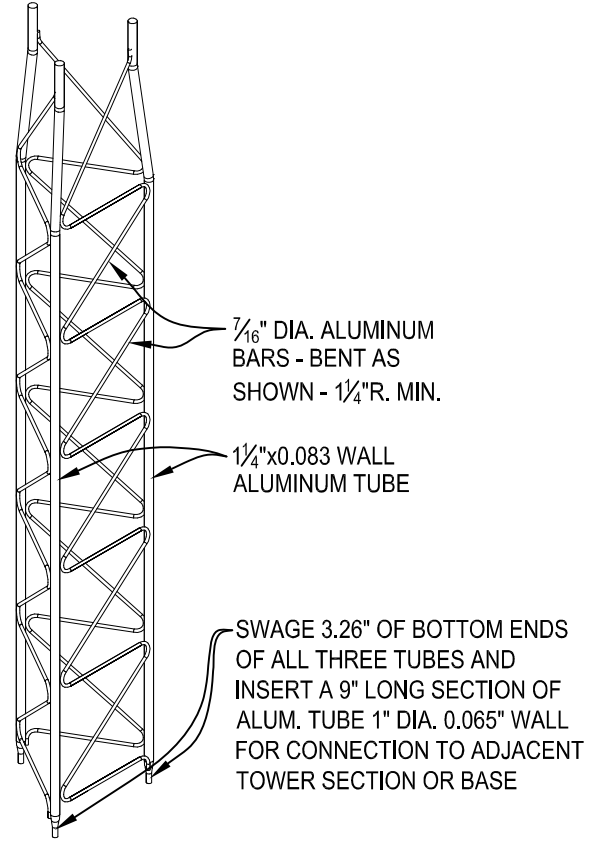

ISOMETRIC 3
SCALE: N.T.S.

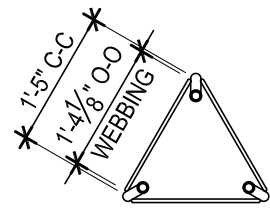

PLAN VIEW 1
SCALE: 1/2"=1'-0"

TAPERED SECTION

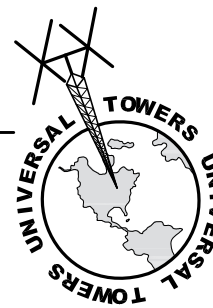

UNIVERSAL TOWERS
A DIVISION OF
UNIVERSAL MANUFACTURING CORP.
43900 GROESBECK HWY.
CLINTON TOWNSHIP, MI 48036
PH: (586) 463-2560
FAX: (586) 463-2964

JOB NO.:

COMPONENT:
18-TAPR

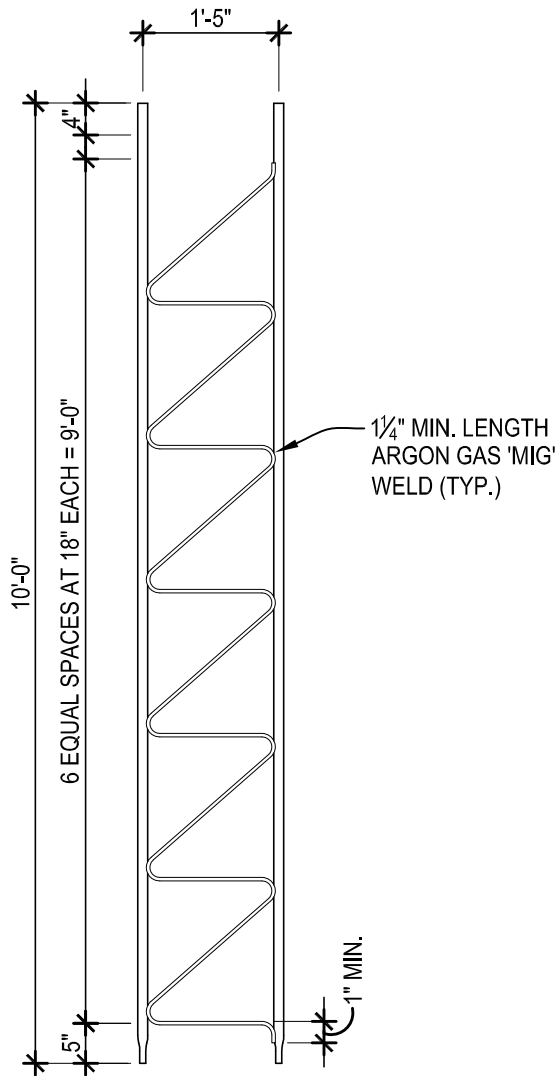

ELEVATION

SCALE: 1/2"=1'-0"

2

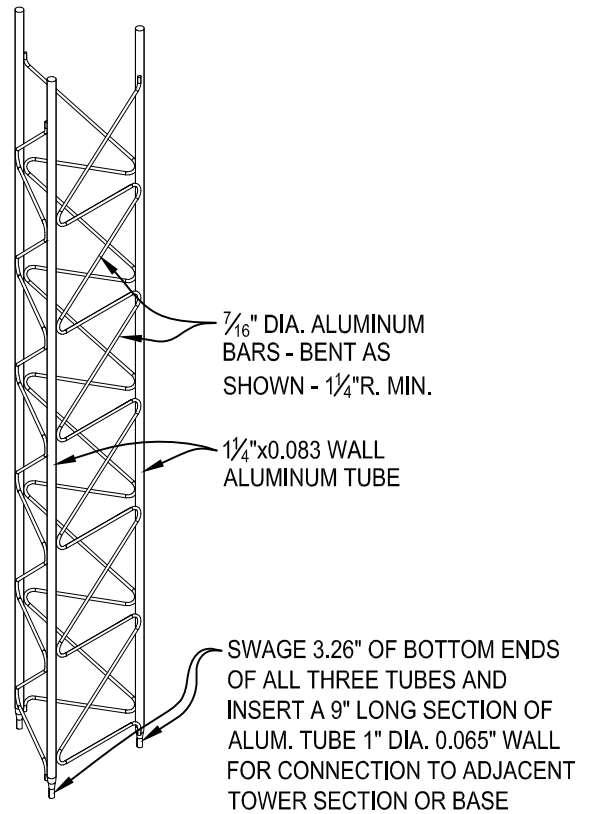

ISOMETRIC

SCALE: N.T.S.

3

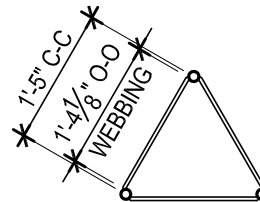

PLAN VIEW

SCALE: 1/2"=1'-0"

1

STRAIGHT SECTION



UNIVERSAL TOWERS
 A DIVISION OF
 UNIVERSAL MANUFACTURING CORP.
 43900 GROESBECK HWY.
 CLINTON TOWNSHIP, MI 48036
 PH: (586) 463-2560
 FAX: (586) 463-2964

JOB NO.:

COMPONENT:

18-STRT

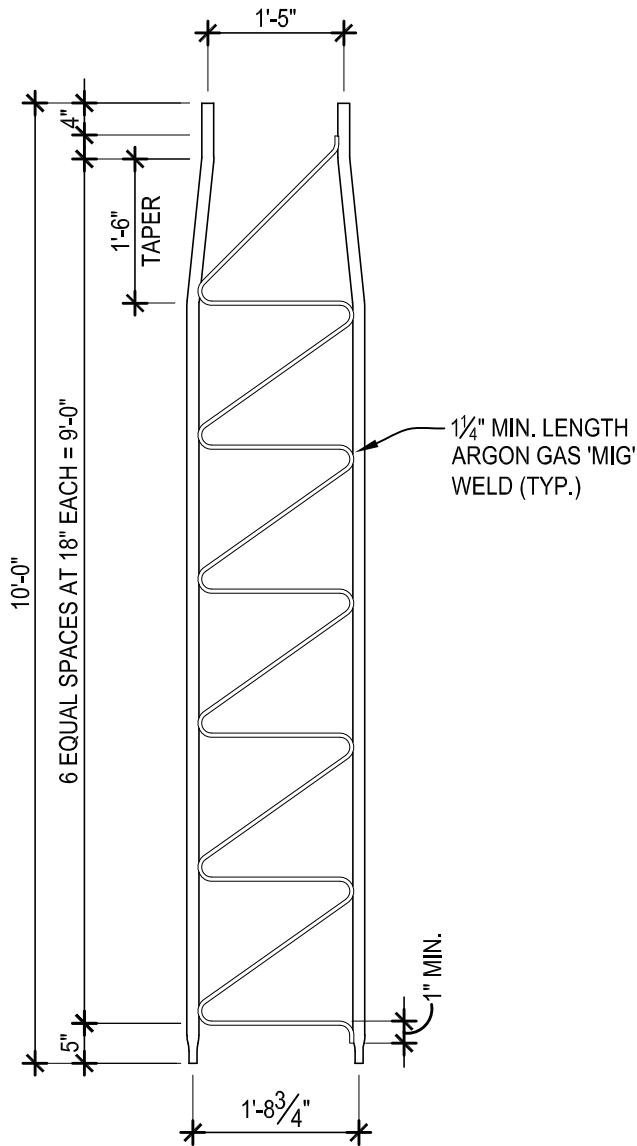

ELEVATION 2
 SCALE: 1/2"=1'-0"

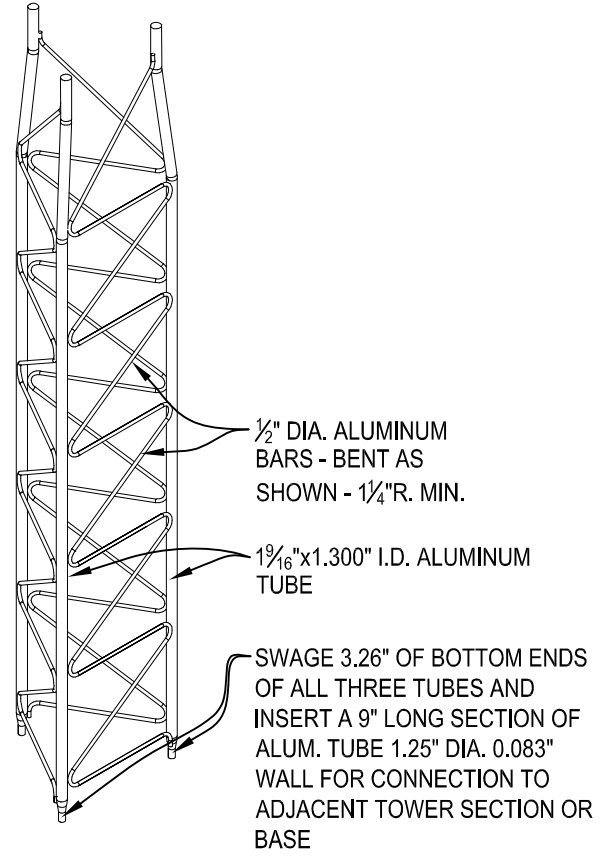

ISOMETRIC 3
 SCALE: N.T.S.

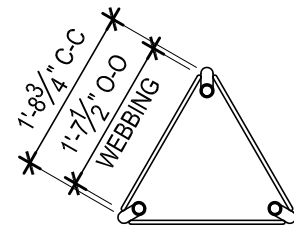

PLAN VIEW 1
 SCALE: 1/2"=1'-0"

TAPERED SECTION



UNIVERSAL TOWERS
 A DIVISION OF
 UNIVERSAL MANUFACTURING CORP.
 43900 GROESBECK HWY.
 CLINTON TOWNSHIP, MI 48036
 PH: (586) 463-2560
 FAX: (586) 463-2964

JOB NO.:

COMPONENT:
22-TAPR

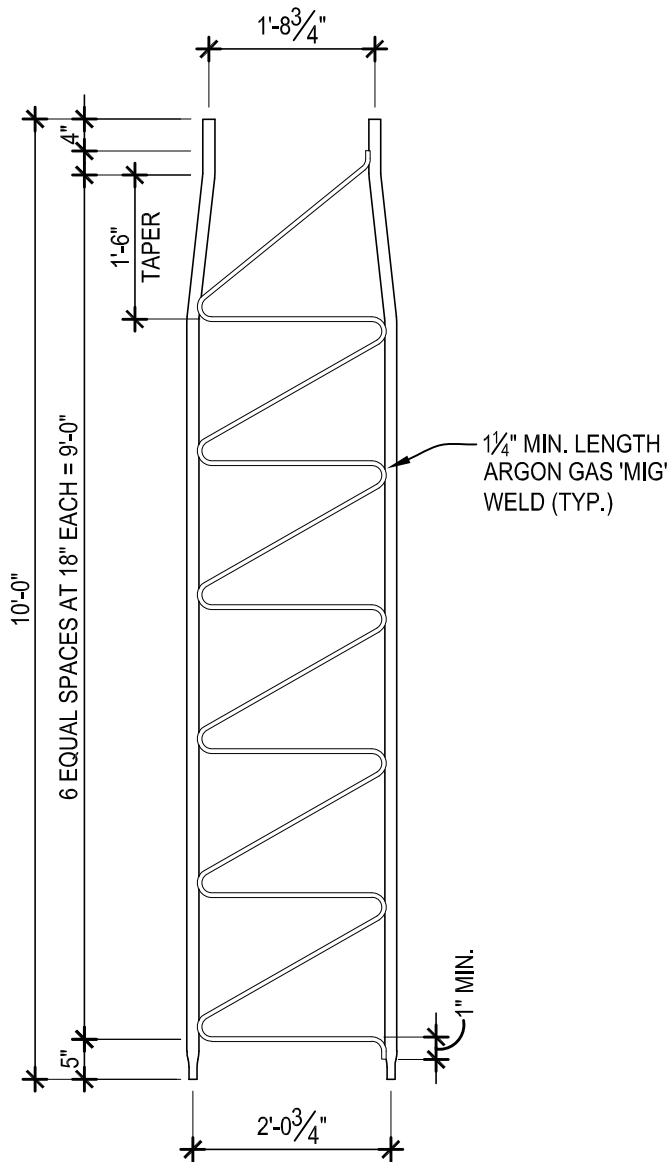

ELEVATION 2
 SCALE: 1/2"=1'-0"

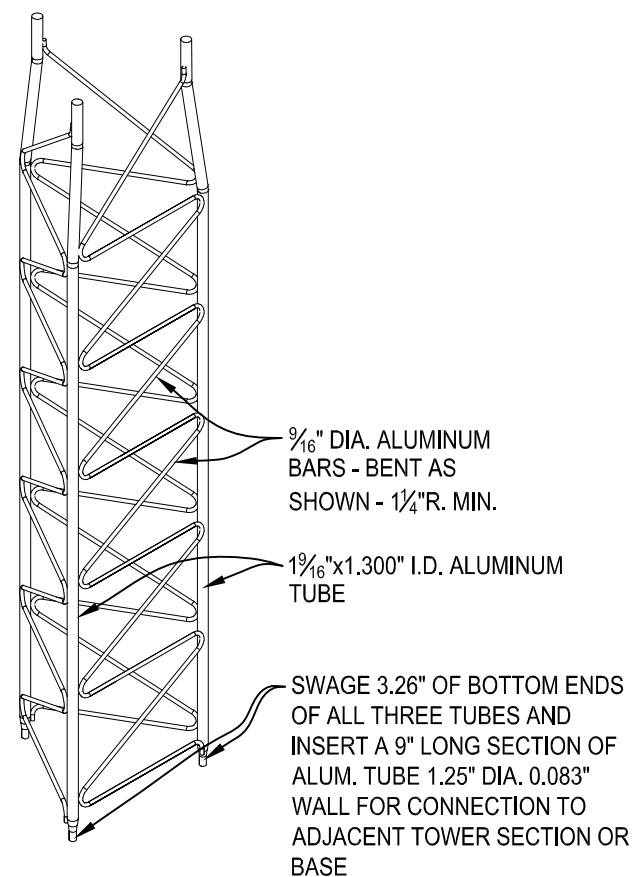

ISOMETRIC 3
 SCALE: N.T.S.

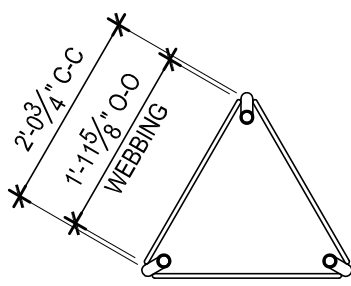

PLAN VIEW 1
 SCALE: 1/2"=1'-0"

TAPERED SECTION



UNIVERSAL TOWERS
 A DIVISION OF
 UNIVERSAL MANUFACTURING CORP.
 43900 GROESBECK HWY.
 CLINTON TOWNSHIP, MI 48036
 PH: (586) 463-2560
 FAX: (586) 463-2964

JOB NO.:

COMPONENT:
26-TAPR

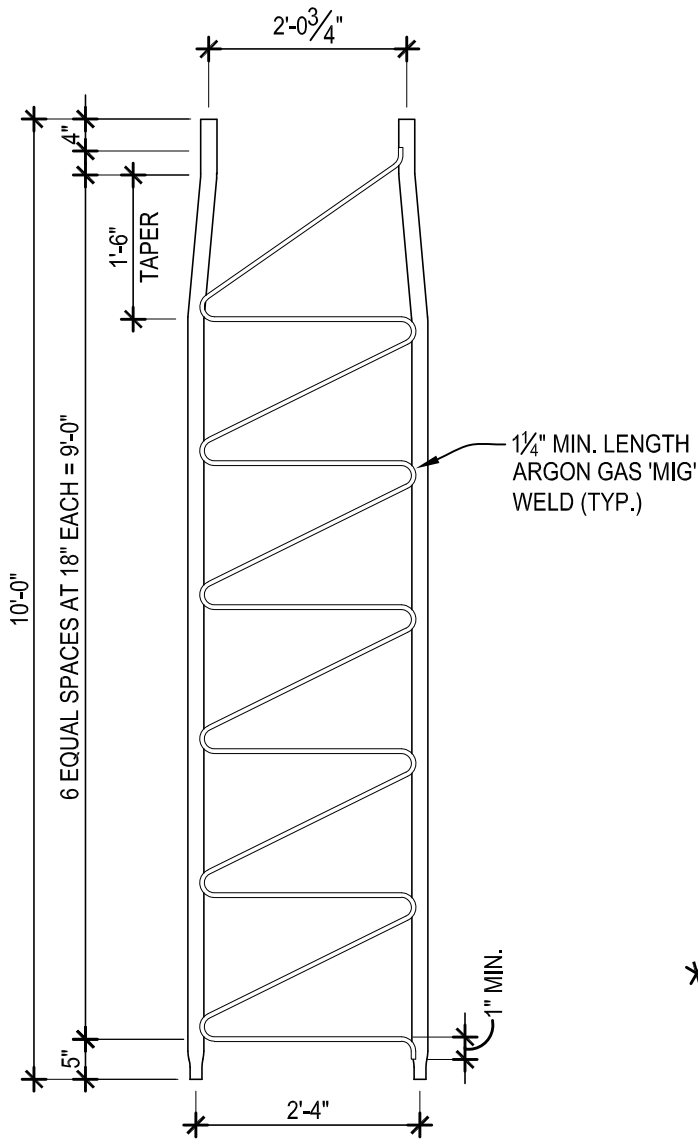

ELEVATION 2

SCALE: 1/2"=1'-0"

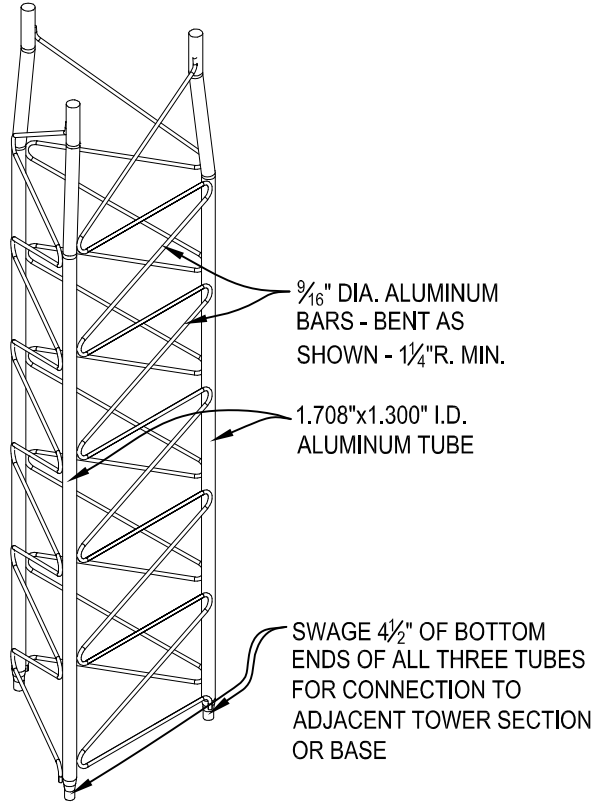

ISOMETRIC 3

SCALE: N.T.S.

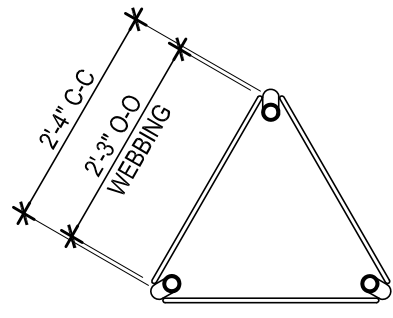

PLAN VIEW 1

SCALE: 1/2"=1'-0"

TAPERED SECTION



UNIVERSAL TOWERS
 A DIVISION OF
 UNIVERSAL MANUFACTURING CORP.
 43900 GROESBECK HWY.
 CLINTON TOWNSHIP, MI 48036
 PH: (586) 463-2560
 FAX: (586) 463-2964

JOB NO.:

COMPONENT:
30-TAPR

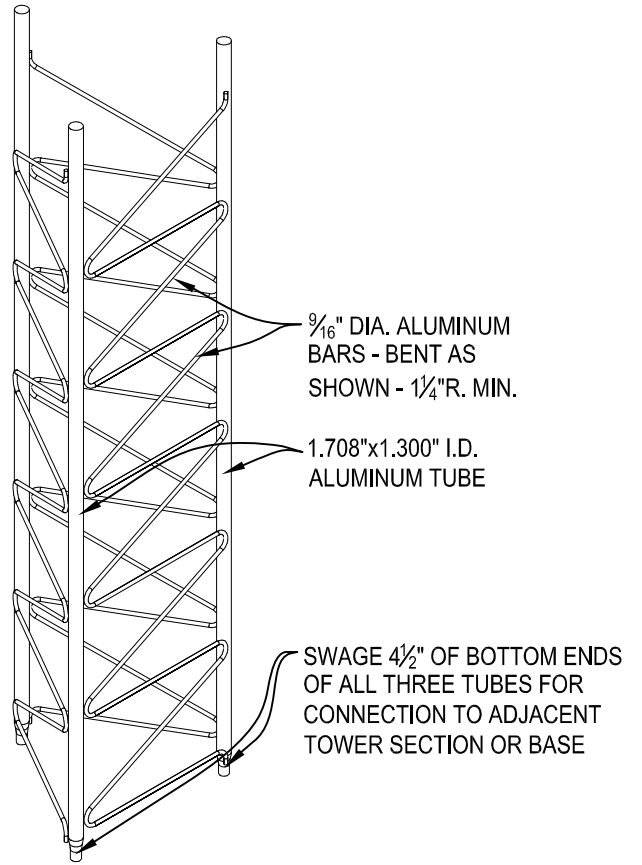
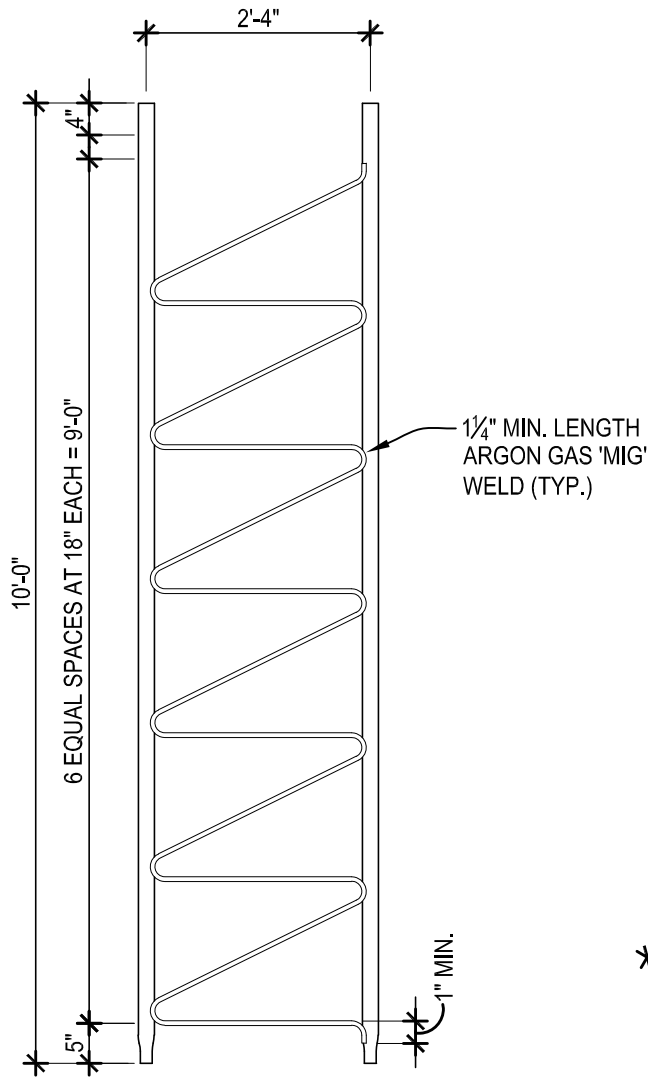

ISOMETRIC

SCALE: N.T.S.

3

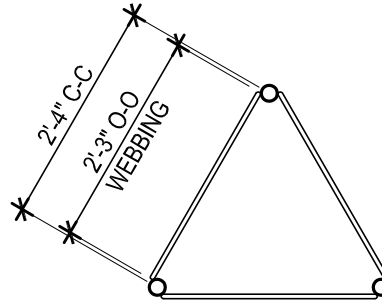

ELEVATION

SCALE: 1/2"=1'-0"

2

PLAN VIEW

SCALE: 1/2"=1'-0"

1

STRAIGHT SECTION



UNIVERSAL TOWERS
 A DIVISION OF
 UNIVERSAL MANUFACTURING CORP.
 43900 GROESBECK HWY.
 CLINTON TOWNSHIP, MI 48036
 PH: (586) 463-2560
 FAX: (586) 463-2964

JOB NO.:

COMPONENT:

30-STRT

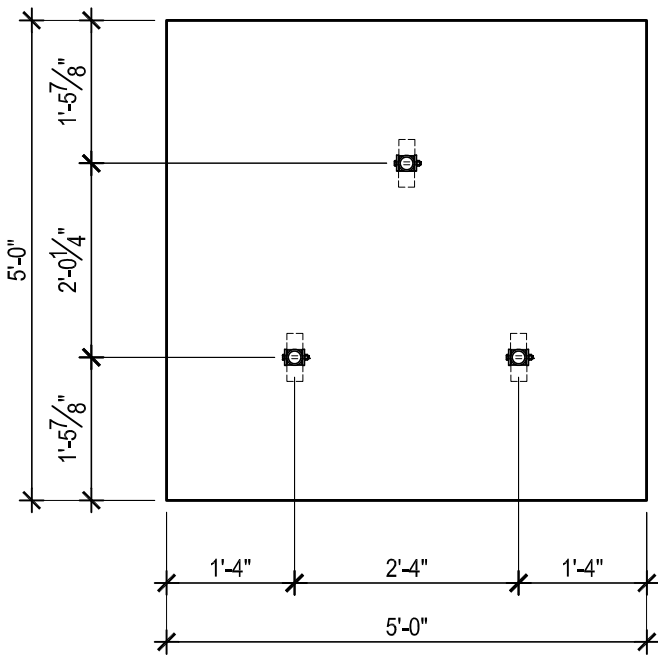

PLAN VIEW 1
SCALE: 1/2"=1'-0"

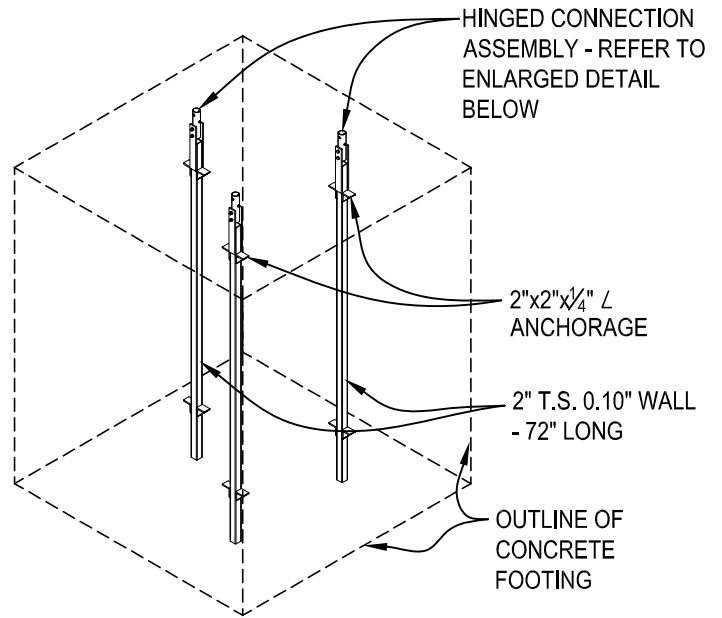

ISOMETRIC 3
SCALE: N.T.S.

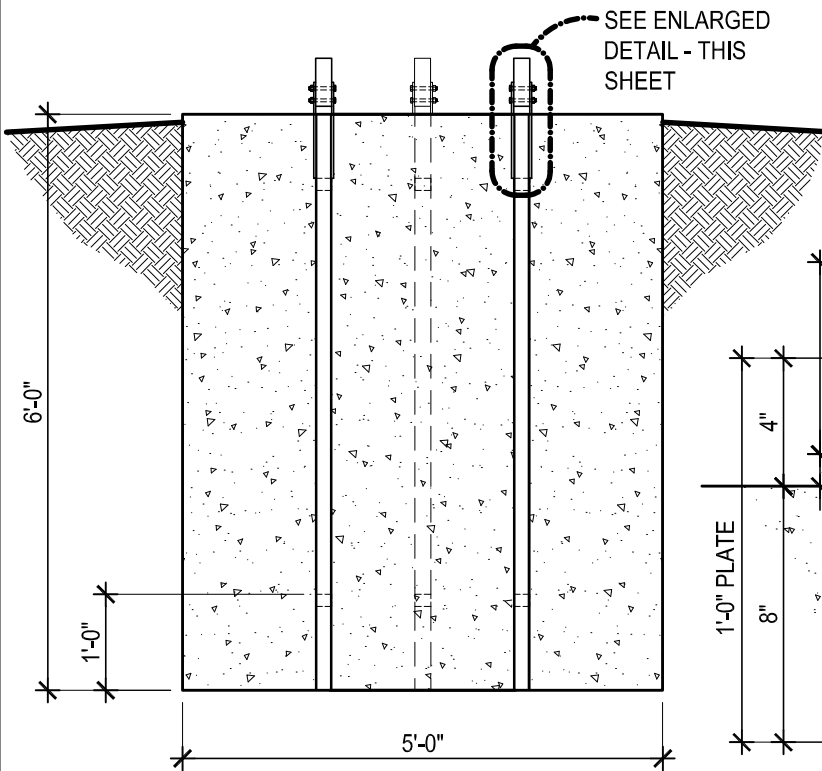

ELEVATION 2
SCALE: 1/2"=1'-0"

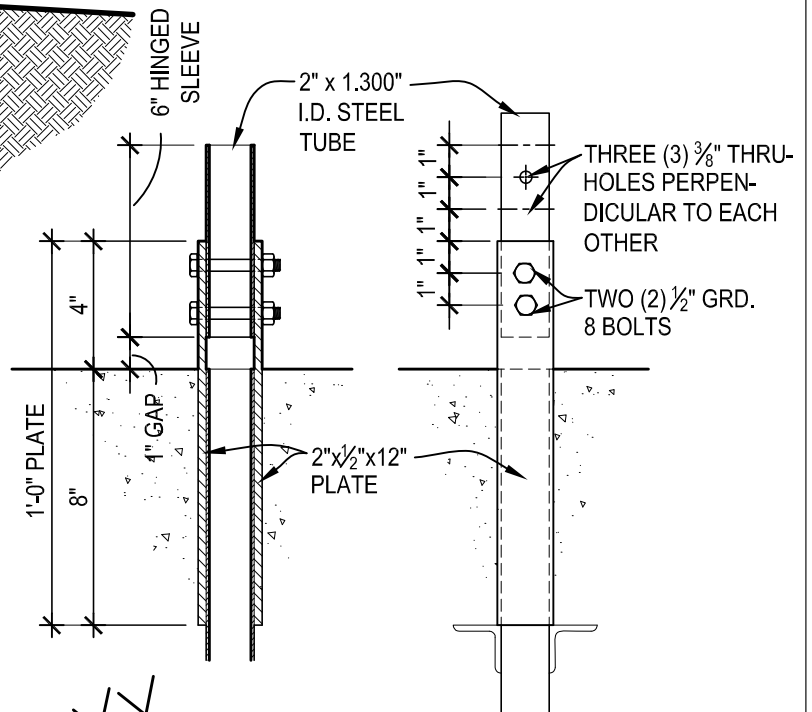

NOTE: FOUNDATIONS ARE DESIGNED FOR FIRM BEARING SOIL.

BASE FOOTING



UNIVERSAL TOWERS
A DIVISION OF
UNIVERSAL MANUFACTURING CORP.
43900 GROESBECK HWY.
CLINTON TOWNSHIP, MI 48036
PH: (586) 463-2560
FAX: (586) 463-2964

JOB NO.:

COMPONENT:

B-30

ATTACHMENT C - SPECIFICATIONS



SmartPoint 520M

Pit Set Module

The SmartPoint® 520M Pit Set Module is a radio transceiver that provides water utilities inbound and outbound access to water measurement and ancillary device diagnostics via radio signal. The SmartPoint 520M is designed for submersible, pit-set environments.

TouchCoupler Design

The SmartPoint 520M Module utilizes TouchCoupler, the patented Sensus inductive coupling communication platform, to interface with the encoded meter. With TouchCoupler, the SmartPoint 520M Module can connect to the meter using existing two wire AMR installations instead of requiring utilities to access the meter to install a new three-wire connection. This results in a fast, efficient and reliable connection at minimal cost.

OPTIONAL FEATURES SIDEBAR

- Easily receives input from either walk-by/drive-by or fixed-base collection device
- Controls both deployment and lifetime operation costs
- Compact installation that saves time, space and money - without reducing system performance
- Delivers a fast, efficient and reliable connection at minimal cost
- Minimizes new infrastructure investment
- Enables effective leak detection

Operation

With its migratable, two-way communication ability, the M-Series SmartPoint functions as a walk-by/drive-by endpoint, fixed-base endpoint, or combination of the two. This flexibility increases utility data collection capabilities and streamlines operations. The SmartPoint 520M Module receives input from the meter register and remotely sends data to a walk-by/drive-by or fixed-base collection device. The SmartPoint 520M Module easily migrates from walk-by/drive-by to fixed base by simply installing a Base Station.

In walk-by/drive-by mode, the SmartPoint 520M Module collects data and awaits an activation signal from the Vehicle Gateway Basestation (VGB) or Hand-Held Device (HHD). Upon signal receipt, it transmits readings, the meter identification number and any alarms.

As a fixed-base endpoint, the SmartPoint 520M Module interacts with one or more strategically placed Base Stations located in the utility service area. Top of the hour readings and other diagnostics are instantly forwarded to the Regional Network Interface (RNI)™ at time of transmission. The FlexNet® communication network provides unmatched reliability by using expansive tower receiver coverage of metering end points, data/message redundancy, failover backup provisions and operation on FCC primary use (unshared) RF spectrum.

Powerful Transmission, Flexible Platform

The SmartPoint® 520M Pit Set Module offers several advantages that control both deployment and lifetime operation costs. Its powerful, industry-leading two watt transmitter broadcasts over large distances and minimizes collection infrastructure. And after the SmartPoint is installed, its migratable, two-way system platform can be updated without requiring personnel to visit each meter and/or inconveniencing customers.

SmartPoint 520M

Pit Set Module

Additional Smartpoint 520M Module Features

The SmartPoint 520M Module obtains hourly readings and can monitor continuous flow over a programmable period of time, alerting the utility to leak conditions. In addition, the SmartPoint stores up to 840 consumption intervals (35 days of hourly consumption), providing the utility with the ability to extract detailed usage profiles for consumer information and dispute resolution. The SmartPoint also incorporates a two-port design, allowing the utility to connect multiple registers and ancillary devices (such as acoustic monitoring) to a single SmartPoint. This results in a compact installation that saves time, space and money - without reducing system performance.

SPECIFICATIONS

Service	Pit set installation interfacing the utility meter to the Sensus FlexNet communication network. Unit requires 1.75" diameter hole in pit lid; fits pit lid thicknesses up to 1.75"
Physical characteristics	Width: 4.43" x Height: 5.09" x Depth: 3"
Weight	1.0 lbs/16.0 oz
Color	Black
Frequency range	900 - 950 MHz, 8000 channels X 6.25 kHz steps
Modulation	Proprietary Narrow Band
Memory	Non-Volatile
Power	Lithium Thionyl Chloride batteries
Approvals	US: FCC CFR 47: Part 24D, Part 101C, Part 15 Licensed operation Canada: Industry Canada (IC) RSS-134, RSS-119
Operating temperature	- 22° F to +185° F - 30° C to + 85° C
Options	Dual or single port availability; TouchCoupler only, wired only
Installation environment	100% condensing, water submersible
Compatibility	TouchCoupler and Wired Version: Sensus Encoder Registers, Badger ADE water registers, Master Meter AccuLinx, and Hersey Translator (approved TR/PL Lead) Wired Version Only: Elster Encoder (Sensus protocol), Neptune ARB VI (ProRead), Hersey Translator, Zenner PMN Nitro 01, McCrometer flowcom FC100-00M, and Kamstrup flowIQ 2100 Refer to the 510M/520M SmartPoint® Module Water Meter and Ancillaries Compatibility Quick Guide for the latest compatibility information.
Warranty	20 years - Based on six transmissions per day. Refer to Sensus G-500 for warranty.



SENSUS | 637 Davis Drive | Morrisville, NC 27560 | 800.638.3748

©2020 Sensus. All products purchased and services performed are subject to Sensus' terms of sale, available at either sensus.com/TC or 1-800-638-3748. Sensus reserves the right to modify these terms and conditions in its own discretion without notice to the customer. The Sensus logo is a registered trademark of Sensus.

This document is for informational purposes only, and SENSUS MAKES NO EXPRESS WARRANTIES IN THIS DOCUMENT. FURTHERMORE, THERE ARE NO IMPLIED WARRANTIES, INCLUDING WITHOUT LIMITATION, WARRANTIES AS TO FITNESS FOR A PARTICULAR PURPOSE AND MERCHANTABILITY. ANY USE OF THE PRODUCTS THAT IS NOT SPECIFICALLY PERMITTED HEREIN IS PROHIBITED.



FlexNet M400B2 Base Station

Compact Point-to-Multipoint Base Station

The Sensus FlexNet® M400B2 Base Station offers a strategic communications option for public service providers with endpoints deployed in remote or densely populated areas.

The efficient transceiver can transmit and receive in a 200kHz band of spectrum. 200kHz enables more dedicated channels, resulting in higher network capacity, allowing more granular data and more channels of data. And the Sensus FlexNet communication network delivers double the transmit power of competitive systems over primary-use licensed spectrum – ensuring reliability for mission critical applications.

The tower-based architecture enables reliable communication of status and usage information with fewer access points than other network architectures. These compact, efficient base stations fit in space-constrained environments and require no air conditioning.

FEATURES

- GPS receiver for time synchronization
- Duplexer for single antenna
- IP-addressable power supply with hot-swap capability
- 8-hour battery backup
- Alarms and reporting capability
- Backhaul via Ethernet/IP
- Heated battery for cold weather environments
- Modular construction for easy serviceability

APPLICATIONS

- Two-way Advanced Meter Infrastructure (AMI)
- Distribution Automation (DA)
- Demand Response (DR)
- Home Area Networks (HAN)
- Sensus VantagePoint® Lighting Control

Licensed Radio Spectrum

In North America, FCC/IC protected primary-use spectrum avoids competition with other wireless services, interference from other radio devices and the risk of being taken over by emergency service providers.

Fewer Access Points

Our point-to-multipoint architecture directly connects base stations to endpoints over large geographic areas – greatly reducing the number of network backhaul connections as well as O&M costs.

Resilient Network Design

Sensus Base Stations continue to provide real time data during outages and emergencies because of eight hour plus battery backup – enabling better workforce management and faster service restoration.

Small Footprint

Flexible pole or wall-mounting options enable strategic deployment with a discreet appearance.

Industry Leading Security

Sensus has achieved GE/Wurldtech™ Achilles® communications certification for critical infrastructure security against cyber threats.

FlexNet® M400B2 Base Station

Compact Point-to-Multipoint Base Station



PROPERTIES

Receive bandwidth	200 KHz
Transceivers	Single
Spectrum	Licensed 900 MHz PCS/MAS
Duplexing	Single transmit Sixteen receivers - simultaneous/dedicated
Applications	Single
Expandability	No
Compatibility	SNMP
FlexNet	Requires RNI 3.x or newer

ENCLOSURES - OUTDOOR - POLE/WALL MOUNT

Height	22" (55.9 cm)
Width x Depth	22" (55.9 cm) x 10.5" (26.7 cm)
Capacity	One transceiver
Temperature	-40° to +122° F (-40° to +50° C)
Voltage	120 VAC
Battery backup	8 hours
NEMA rating	4
Air conditioned	No



SENSUS | 637 Davis Drive | Morrisville, NC 27560 | 800.638.3748

©2020 Sensus. All products purchased and services performed are subject to Sensus' terms of sale, available at either [sensus.com/TC](https://www.sensus.com/TC) or 1-800-638-3748. Sensus reserves the right to modify these terms and conditions in its own discretion without notice to the customer. The Sensus logo is a registered trademark of Sensus.

This document is for informational purposes only, and SENSUS MAKES NO EXPRESS WARRANTIES IN THIS DOCUMENT. FURTHERMORE, THERE ARE NO IMPLIED WARRANTIES, INCLUDING WITHOUT LIMITATION, WARRANTIES AS TO FITNESS FOR A PARTICULAR PURPOSE AND MERCHANTABILITY. ANY USE OF THE PRODUCTS THAT IS NOT SPECIFICALLY PERMITTED HEREIN IS PROHIBITED.

Nothing's out of reach.



MAKING YOUR DATA INSIGHTS SIMPLE, RELEVANT AND ACTIONABLE

Sensus Analytics



SENSUS
a xylem brand

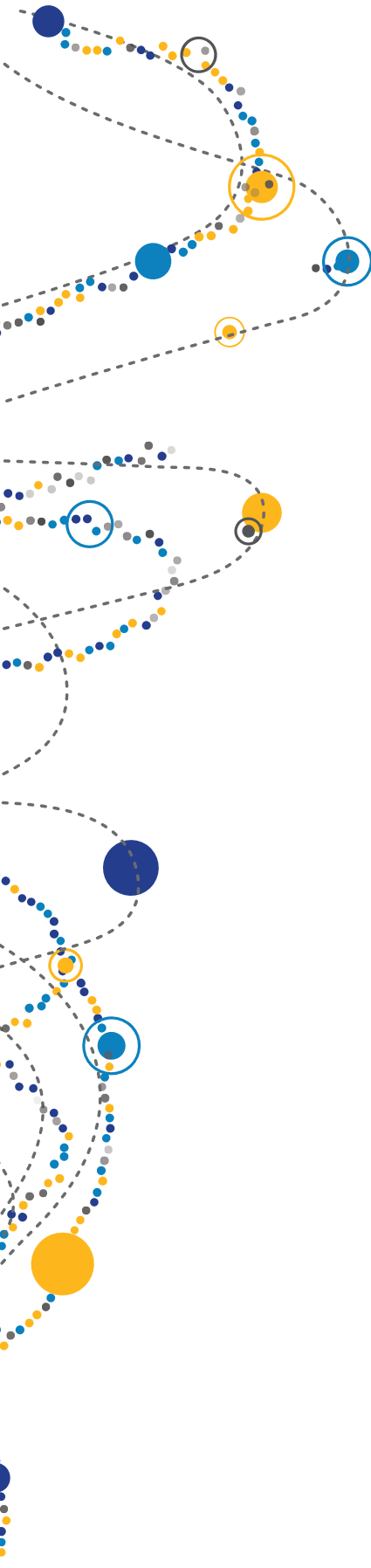

Convert smart data into smarter insight.

Utilities know that collecting the right information from meters and sensors is the best way to optimize a system and make the most of every investment. But the data itself doesn't tell the whole story. It's the process of sorting through this data—the analytics—that reveals relevant, actionable insights to help improve everything from operations to customer service.

Sensus Analytics provides the functionality needed to do just that. Our customizable suite of applications provides user-friendly dashboards that help you make informed decisions quickly and confidently. Our powerful data management tools aggregate information from your AMI, AMR and other sources. A secure connection to the cloud delivers these intuitive apps right to your desktop, tablet or smartphone.

With intuitive applications that are quick to implement and easy to use, you can rely less on IT resources. And role-based access allows service providers to share information across the organization for improved productivity, operational efficiency and customer satisfaction.

Experience tailor-made analytics for tailored results.

Data analytics is not a one-size-fits-all strategy. So Sensus Analytics offers you the flexibility to buy single applications or pre-bundled packages of our most popular apps to ideally fit your business needs. With Sensus Analytics, you have the power to extract value from your data through our industry-proven descriptive analytics. Not only can you see where you've been and where you are now, but you can also perform predictive analytics for actionable insights on what may happen in the future.

It's a good day when the power is on, the water is clean, and gas is safely flowing. Sensus Analytics gives you the foresight and insight to make every day a good day.

Sensus Analytics is the heart of our smart utility technology.

Big data is a big deal—but it doesn't have to be intimidating. Our advanced analytics provide all the number-crunching you need in an intuitive user-friendly approach to take your utility to the next level of smart. Here are just some of the valuable benefits:



<p>App-based</p> <p>Each purpose-built application accesses data from multiple systems and presents it in user-friendly dashboards.</p>	<p>Affordable</p> <p>Our flexible packages allow you to buy as many or as few apps as you need to meet your business goals. And when things change? No problem. Just add another app to your existing Sensus Analytics system without any hassle.</p>
<p>Accessible</p> <p>Our secure, cloud-based delivery platform puts your information within reach no matter where you are.</p>	<p>Real-time Analysis</p> <p>Applications are continuously updated as information enters the system, so you can make decisions based on the latest data.</p>
<p>Scalable</p> <p>Our Data Store, along with three years of cloud-based storage, enables you to add applications or increase storage quickly—often in hours.</p>	<p>Integration-ready</p> <p>Sensus Analytics draws information from many systems through the cloud, so little time and cost are required for standard systems integration.</p>
<p>Visible</p> <p>Role-based access allows information sharing across the organization—from customer service and operations to accounting and rates—for improved efficiency and cross-functional understanding.</p>	<p>Secure</p> <p>Guided by dedicated security teams, backed by best-practice policies and strict standards, and committed to swiftly handling evolving risks, Sensus meets the existing and future security needs of our utility customers.</p>

Sensus Essential Analytics

Ready. Set. Mobilize.

Sensus Essential Analytics is a bundle of applications to quickly provide the core meter data management performance you need without the high cost, commitment to enterprise-wide integration or seemingly endless learning curve.



Admin

A management tool for system-level settings including access and privileges, device groups, billing calendars and more.



Report Access

A business intelligence tool that offers a menu of reports that instantly summarize the information you need to know right away.



Device Access

A customer service tool that, combined with account and customer information, presents detailed usage history and trends, identifies anomalies and enables custom alert programming to track specific issues.



Billing Access

A billing interface tool that previews and audits billing extracts for issues, enabling the utility to take corrective action and then generate final billing files for production.



Meter Insight

A dashboard providing a summary of incoming network, account and meter data to identify and prioritize issues needing to be addressed.

Validation, estimation and editing. This is not your grandfather's VEE.

With the Sensus FlexNet[®] communication network, you're getting data at over two times the power of competitive systems. The need for many of the historical features of VEE becomes obsolete when you're running an accurate, reliable system. Many components of VEE are built right into our architecture and software. Our private network means you'll never have transmission interference or have to share frequencies. Designed for 100% coverage, even during major storm events, your data is transmitted securely and reliably over spectrum that is protected by federal law.

Sensus doesn't just meet the intent of VEE. We do it better.

Sensus Enhanced Analytics

Ready. Set. Analyze.

In addition to the key features found in Essential Analytics, Sensus Enhanced Analytics also provides alarm management capabilities. Go beyond billing applications to get true insight on system performance and health.



Alert Manager

A notification tool to immediately alert individuals, teams or key customers on conditions such as high temperature, high/low voltage, power failure/restoration, leakage and tampering.



Alarm Insight

A monitoring tool for your entire system with near-real-time alarms, allowing you to drill down into individual events, view historical data and map the alarm events to watch event trends.

Secure by design

All Sensus solutions have been designed and built from the ground up to provide end-to-end security protection. Our security policies and practices are continuously driven by customer feedback, industry standards and best practices, and emerging and potential threats. Our security controls are rigorously guided by the requirement to maintain the "CIA triad":

- Confidentiality of data
- Integrity of data
- Availability of services





Sensus Advanced Analytics

Ready. Set. Customize.

Sensus Advanced Analytics is a flexible option that combines our easy-to-use applications and professional services to create a solution tailored for your needs. In addition to the key capabilities found in Essential and Enhanced, Sensus Advanced Analytics offers additional features and lets you choose the right applications to best fit your business needs.



Unbilled Insight

A forecasting tool providing an up-to-date view of service delivered but not yet billed, so you can accurately predict future revenue for upcoming billing cycles.



Energy Insight

A tool providing a “bottom up” view of loading along the circuit, enabling an unprecedented view of your system that allows you to understand what is being asked of the distribution design.



Transformer Utilization

An aggregation-based tool to determine potential transformer failure and help right-size installations. Coming soon: tools that expand analysis to additional devices including fuses and switches.



Voltage Insight

A tool uncovering opportunities where you can lower and balance voltage across your distribution territory during high-use periods and reduce the need to purchase energy at expensive peak prices.



Outage Management

A tool to display all active outages and recent restorations. Enhanced reporting capabilities will be added soon.



Acoustic Monitoring

An acoustic leak detection analysis tool used in conjunction with PermaLog devices to identify leaks in distribution systems.



Hidden Revenue Locator

A perfect application for a water meter testing and replacement program, this app examines meter inaccuracies to identify apparent losses. This solution empowers proactive revenue recovery and operational efficiencies through identifying meter under-performance due to under-registration, meter read errors and incorrect meter sizing.



Service Management

COMING SOON!

A tool providing remote shut off and activation of large numbers of valves inside Sensus devices. In contrast to tools for Field Technicians, this application is designed for Customer Service Representatives or others working from an office.



Daily Reads

A data collection tool for daily time-dependent meter readings. For example, reconciling rate vs. consumption for utilities working with transportation customers.

Smart City Innovations

Utility systems are fundamental to every city, and smarter management of this infrastructure is the foundation for any smart city. Go beyond metering to true intelligent resource management and monetization of your assets.

With Sensus Smart Gateways, the FlexNet® communication network and Sensus Analytics, the potential of smart is endless.

Analyze data from more than 100 types of sensors, including temperature, pressure, depth, distance, light, smoke and more.

- Make sure storm drains are clear before possible flooding
- Know when city garbage cans are full and need servicing
- Enable drivers to find open public parking spaces
- And discover many, many more smart city applications

We give you the tools to build your smart city. Only your imagination and innovation set the limits.

Sensus Analytics and the Customer Portal enabled

Cedar Park, Texas, to quickly catch continuous flow, sending leak alerts and tier-billing information to residents. In the first year, the water municipality saved \$67,000 and 15 million gallons of water.



\$67,000



15 million gallons

Customer Portal

Engage customers for smart impact.

Sensus Analytics Customer Portal is a web-based, custom-branded, interactive application for utility consumers. This intuitive portal provides virtually everything a consumer needs to understand consumption patterns, correct current issues and make more informed decisions about future usage. Customer Portal also serves as an additional communication channel for the utility to provide enhanced customer service.

Customer Portal provides the consumer with the most current data available—the same data that the utility customer service representative is observing in Sensus Analytics. For example, a customer can see hourly water consumption down to a gallon, updated every four hours. No other utility analytics package on the market can provide this level of speed and detail. Your customers can use this information to set up alerts for managing daily usage, billing cycle usage and even vacation alerts.



Helping drive the success of your business.

Sensus Analytics goes beyond data analysis to streamline your entire organization's workflows and create more efficient operations. Sensus Analytics combines analytical information with business processes to enable smart and fast data-driven decisions for improved service and revenue.

While other software packages are designed for all industries and built for users with a high degree of expertise or years of experience, Sensus Analytics is made by utility experts for utilities. We know every utility is unique, so our software is right-sized and flexible—and you don't need to be a statistician or data scientist to use it. Our approach provides applications targeting daily utility functions that make managing the AMR or AMI system an integral part of managing the utility's existing goals.

With Sensus Analytics, you can focus on what you really want: near-real-time analysis of data to understand trends, improve operations and enhance customer experiences.



Prepare and execute billing on meters



Support customer service



Maintain and manage meter performance and data



About Sensus

Sensus, a Xylem brand, helps a wide range of public service providers—from utilities to cities to industrial complexes and campuses—do more with their infrastructure to improve quality of life in their communities. We enable our customers to reach farther through the application of technology and data-driven insights that deliver efficiency and responsiveness. We partner with them to anticipate and respond to evolving business needs with innovation in sensing and communications technologies, data analytics and services. Learn more at sensus.com and follow us on Facebook, LinkedIn and Twitter through @sensusglobal.

Sensus by the numbers

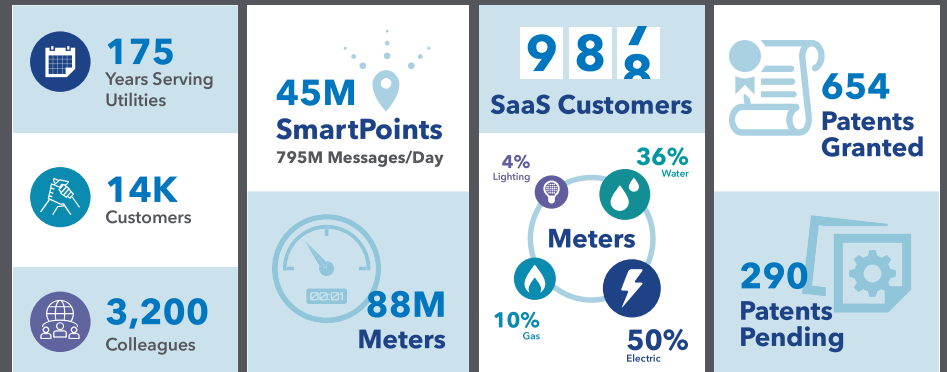

ATTACHMENT D – OPUD BOUNDARY MAP

Olivehurst Public Utility District - Boundary With Fire Service Area And Sphere Of Influence

