

Olivehurst Public Utility District



Agenda Item Staff Report

Meeting Date: 06/20/24

Item description/summary:

Consider RFB for OPUD Wastewater Treatment Plant Flow Meter and Transmitter.

Olivehurst Public Utility District (OPUD) is requesting Bids for Replacement of Effluent meter and transmitter. Bids will be open for 3+ weeks and will be due on July 9th, 2024. The existing effluent meter has been very inconsistent in providing accurate data of effluent flow and this is an important piece of equipment that needs to be ordered asap.

Fiscal Analysis:

n/a

Employee Feedback

n/a

Sample Motion:

Move forward for Request for Bid

Prepared by: Swarnjit Boyal, Public Work Engineer

EXHIBIT A – BID SET

OLIVEHURST PUBLIC UTILITY DISTRICT

NOTICE OF REQUEST FOR SEALED BID'S

(DATE) JUN 20, 2024

OWNER: **Olivehurst Public Utility District**
PROJECT: **WASTEWATER REPLACEMENT ROSEMOUNT 8700M 24”
MANGNETIC FLOWMETER (Part# 8705TSA240C1M0N5G1) &
TRANSMITTER (Part#8712EMR1A1N5M4)**

TO: Contractor / Bidder

BID DUE DATE: July 9, 2024 2:00 P.M.

BID OPENING DATE/TIME: July 9, 2024 Shortly after Bid Due Date.

SUBMIT BID

TO: **Olivehurst Public Utility District**
1970 9th Avenue
Olivehurst, CA 95961
(530) 682-0736

Notice is hereby given to all prospective Contractors / Suppliers to submit a sealed BID on or before the above date. Contractor / Supplier agree to supply and/or to perform all the work described in the available CONTRACT DOCUMENTS consisting of Plans, proposal document and Specifications. Copies of the CONTRACT DOCUMENTS may be obtained from Olivehurst Public Utility District, upon the non-refundable payment of \$ 50 per set, or you may request a free electronic copy from the District Engineer via email at sboyal@opud.org.

Sincerely,



Swarnjit Boyal, MS
Public Works Engineer

OLIVEHURST PUBLIC UTILITY DISTRICT

1970 9TH Avenue
Olivehurst, CA 95961
Phone: (530) 743-4657

OLIVEHURST PUBLIC UTILITY DISTRICT

Our mission is to provide high quality services to enhance our community's quality of life.



BOARD OF DIRECTORS

Dennise Burbank Lacey Nelson John Floe Mary Jane Griego Marc Perrault

GENERAL MANAGER

John Tillotson

June 20, 2024

To: Prospective Bidders

RE: Purchase of a Rosemount 8700M 24" Magnetic Flowmeter AND Transmitter

Olivehurst Public Utility District will be accepting as specified below:

1.) Rosemount 8705 Flanged Sensor: (Part# 8705TSA240C1M0N5G1) Fully welded sensor for maximum protection

DESCRIPTION

8705240	ROSEMOUNT 8705 FLANGED MAGNETIC FLOW METER SENSOR, 24 INCH (DN600)
T	Lining Material: PTFE
S	Electrode Material: 316L Stainless Steel
A	Electrode Type: 2 Measurement Electrodes - Standard
C	Flange Type and Material: Slip-On, Raised-Face, Carbon Steel
1	Flange Rating: ASME B16.5, Class 150 (1/2" thru 24"); AWWA Class D (30" & 36")
M0	Coil Housing Configuration: Sealed, Welded Housing
N5	US Approvals, Class I Div 2, Non-Incendive with I.S. Electrodes, and Dust
G1	Grounding Rings: Grounding Ring - 316L Stainless Steel (Qty 2)
Qty	1

2.) Rosemount 8712E Magnetic Flow Meter Transmitter: (Part#8712EMR1A1N5M4) Wall mount design, backlit display, 15-Button tactile key pad

DESCRIPTION

8712E	ROSEMOUNT 8712E MAGNETIC FLOW METER TRANSMITTER
M	Transmitter Class: Revision 4 Electronics
R	Transmitter Mount: Remote Wall Mount
1	Transmitter Power Supply: AC Power Supply (90 to 250VAC, 50-60Hz)
A	Transmitter Outputs: 4-20mA; Digital HART; Scalable Pulse
1	Conduit Entry: 1/2-14 NPT
N5	Safety Approvals: US Approvals, Class I Div 2, Non-Incendive and Dust
M4	Display Option: Local Operator Interface
Qty 1	
	Calibration
	Flow Units : ft/sec
	LRV for output : 0.0
	URV for output : 30.0

No substitutes or equals. Bids shall include any and all taxes, freight, federal/state fees etc. and be an 'Out-The-Door' cost. Any questions shall be directed to the OPUD Public Works Department at 530 682-0736.

Rosemount™ 8700M Magnetic Flowmeter Platform





- Industry leading performance:
 - Standard reference accuracy of 0.25% of rate
 - High reference accuracy of 0.15% of rate (optional)
- Rosemount 8732 Transmitter: Integral and remote mount designs, backlit display, and explosion-proof housing
- Rosemount 8712 Transmitter: Wall mount design, backlit display, 15-Button tactile key pad
- Available in 4-20 mA with HART®, FOUNDATION™ Fieldbus, Modbus® RS-485, Intrinsically Safe (I.S.) outputs, Process Diagnostics, and SMART™ Meter Verification to improve reliability and performance
- Rosemount 8705 Flanged Sensor: Fully welded sensor for maximum protection
- Rosemount 8711 Wafer Sensor: Economical, compact, fully welded, and lightweight sensor, provided with alignment spacers for easy installation
- Rosemount 8721 Hygienic (Sanitary) Sensor: Specifically designed for food, beverage, and life sciences applications

Product Selection Guide

The Rosemount 8700M Magnetic Flowmeter Platform is available in a variety of sensor styles and configurations to ensure compatibility with virtually all applications and installations.

Other liner and electrode materials not listed may be available. Contact your local sales representative. For further guidance on selecting materials, refer to the Magnetic Flowmeter Material Selection Guide located on Rosemount.com (Technical Data Sheet Number [00816-0100-3033](#)). For more information regarding the available product offering see the ordering information, [Table 6](#) thru [Table 18](#).

Transmitter selection

Transmitter	General characteristics
<p>8732</p> 	<ul style="list-style-type: none"> ▪ Integral and remote configurations available ▪ HART/Analog and Pulse outputs available ▪ FOUNDATION™ Fieldbus and pulse output available ▪ Modbus RS-485 and Pulse output available ▪ Advanced Diagnostics available ▪ LCD display, optional (with optional optical switch local operator interface)⁽¹⁾ ▪ Three independent totalizers (A/B/C) ▪ Two discrete channels (optional)
<p>8712</p> 	<ul style="list-style-type: none"> ▪ Wall mount configuration ▪ HART/Analog and Pulse outputs available ▪ Modbus RS-485 and Pulse output available ▪ FOUNDATION™ Fieldbus and pulse output available ▪ Advanced Diagnostics available ▪ Local LCD display, optional (with optional 15 button tactile key pad ⁽¹⁾) ▪ Three independent totalizers (A/B/C) ▪ Two discrete channels, optional



(1) HART or Modbus protocol only.

Contents

Product Selection Guide.....	2
Magmeter Diagnostics.....	4
Magnetic flow meter sizing.....	5
Ordering information.....	8
Product specifications.....	38
Product certifications.....	65
Dimensional drawings.....	66

Sensor selection

Table 1: Sensor Selection

Sensor	General characteristics
<p>8705</p> 	<ul style="list-style-type: none"> ▪ Standard process sensor ▪ Flanged process connections ▪ Welded, sealed coil housing ▪ ½ -in. (15 mm) to 36-in. (900 mm) ▪ Standard, reference, bullet-nose, and flat electrodes available
<p>8711</p> 	<ul style="list-style-type: none"> ▪ Economical, compact, and lightweight alternative to flanged sensors ▪ Wafer (flangeless) design ▪ Welded, sealed coil housing ▪ 1½ -in. (40 mm) to 8-in. (200 mm) ▪ Standard, reference, and bullet-nose electrodes available
<p>8721</p> 	<ul style="list-style-type: none"> ▪ Hygienic (sanitary) sensor ▪ Designed for food, beverage, and pharmaceutical applications ▪ Variety of industry standard process connections ▪ ½ -in. (15 mm) to 4-in. (100 mm) ▪ 3-A certified ▪ Suitable for CIP/SIP

Magmeter Diagnostics

Rosemount diagnostics reduce cost & improve output by enabling new practices

Rosemount Magnetic Flowmeters provide device diagnostics that detect and warn of abnormal situations throughout the life of the meter - from installation to maintenance and meter verification. With Rosemount Magnetic Flowmeter diagnostics enabled, plant availability and throughput can be improved, and costs through simplified installation, maintenance and troubleshooting can be reduced.

Table 2: Magnetic flowmeter diagnostics

Diagnostic name	Diagnostic category	Product capability
Basic diagnostics		
Grounding and Wiring Fault	Installation	Standard
Tunable Empty Pipe	Process	Standard
Electronics Temperature	Meter Health	Standard
Coil Fault	Meter Health	Standard
Transmitter Fault	Meter Health	Standard
Reverse Flow	Process	Standard
Coil current	Maintenance	Standard
Electrode saturation	Process/Maintenance	Standard
Advanced diagnostics		
High Process Noise	Process	Suite 1 (DA1)
Coated Electrode Detection	Process	Suite 1 (DA1)
Commanded Smart Meter Verification	Meter Health	Suite 2 (DA2)
Continuous Smart Meter Verification	Meter Health	Suite 2 (DA2)
4-20 mA Loop Verification ⁽¹⁾	Installation	Suite 2 (DA2)

(1) Available with HART output only.

Options for accessing diagnostics

Rosemount Magmeter Diagnostics can be accessed through the Local Operator Interface (LOI), ProLink® III v3.1, a HART Field Communicator⁽¹⁾, and AMS® Suite: Intelligent Device Manager⁽¹⁾. Contact your local Rosemount representative to activate diagnostics or for diagnostic availability on existing transmitters.

Access diagnostics through the LOI for quicker installation, maintenance, and meter verification

Rosemount Magnetic Flowmeter Diagnostics are available through the LOI to simplify maintenance.

Access diagnostics through ProLink III v. 3.0 (HART)/ProLink III v. 3.1 (HART, Modbus)

Simplify maintenance and troubleshooting practices by utilizing ProLink III v3.0/v3.1 to access diagnostics and troubleshooting information, log variable data, run SMART Meter Verification, and print verification reports.

Access diagnostics through AMS Intelligent Device Manager⁽¹⁾ for the ultimate value

The value of the diagnostics increases significantly when AMS Intelligent Device Manager is used. AMS Intelligent Device Manager provides a simplified screen flow and procedures for how to respond to the diagnostic messages.

(1) Available with HART output only.

Magnetic flow meter sizing

Selecting the appropriate sensor size is an important step when considering a magnetic flow meter. The physical properties of the process fluid, as well as the fluid velocity should be considered. It may be necessary to select a flow sensor that is larger or smaller than the adjacent piping to ensure the fluid velocity is in the recommended flow range for the application.

Table 3: Sizing guidelines

Application	Velocity range (ft/s)	Velocity range (m/s)
Full Range	0 to 39	0 to 12
Preferred Service	2 to 20	0.6 to 6.1
Abrasive Slurries	3 to 10	0.9 to 3.1
Non-Abrasive Slurries	5 to 15	1.5 to 4.6

Note

Operation outside these guidelines may also give acceptable performance.

To convert flow rate to velocity, use the appropriate factor listed in [Table 4](#) and the following equation:

$$\text{Velocity} = \frac{\text{Flow Rate}}{\text{Factor}}$$

Example: English units	Example: SI units
Magmeter Size: 4 in. (factor from Table 4 = 39.679) Normal Flow Rate: 300 GPM $\text{Velocity} = \frac{300 \text{ (gpm)}}{39.679}$ <p style="text-align: center;">Velocity = 7.56 ft/s</p>	Magmeter Size: 100 mm (factor from Table 4 = 492.78) Normal Flow Rate: 800 L/min $\text{Velocity} = \frac{800 \text{ (L/min)}}{492.78}$ <p style="text-align: center;">Velocity = 1.62 m/s</p>

Table 4: Line size vs. conversion factor

Nominal line size—Inches (mm)	Gallons per minute factor	Liters per minute factor
½ (15)	0.947	11.762
1 (25)	2.694	33.455
1½ (40)	6.345	78.806
2 (50)	10.459	129.89
2 ½ (65)	14.923	185.33
3 (80)	23.042	286.17
4 (100)	39.679	492.78
5 (125)	62.356	774.42
6 (150)	90.048	1,118.3
8 (200)	155.93	1,936.5
10 (250)	245.78	3,052.4
12 (300)	352.51	4,378.0
14 (350)	421.70	5,237.3

Table 4: Line size vs. conversion factor (continued)

Nominal line size—Inches (mm)	Gallons per minute factor	Liters per minute factor
16 (400)	550.80	6,840.6
18 (450)	697.19	8,658.6
20 (500)	866.51	10,761
24 (600)	1,253.2	15,564
30 (750)	2006.0	24,913
36 (900)	2,935.0	36,451

Table 5: Line size vs. velocity/rate

Nominal line size in inches (mm)	Minimum/maximum flow rate							
	Gallons per minute				Liters per minute			
	at 0.04 ft/s (low-flow cutoff)	at 1 ft/s (min range setting)	at 3 ft/s	at 39.37 ft/s (max range setting)	at 0.012 m/s (low-flow cutoff)	at 0.3 m/s (min range setting)	at 1 m/s	at 12 m/s (max range setting)
½ (15)	0.038	0.947	2.841	37.287	0.141	3.529	11.76	141.15
1 (25)	0.108	2.694	8.081	106.05	0.401	10.04	33.45	401.46
1½ (40)	0.254	6.345	19.04	249.82	0.946	23.64	78.81	945.67
2 (50)	0.418	10.459	31.38	411.77	1.559	38.97	129.89	1,558.7
2½ (65)	0.597	14.923	44.77	587.51	2.224	55.60	185.33	2,224.0
3 (80)	0.922	23.042	69.13	907.17	3.434	85.85	286.17	3,434.0
4 (100)	1.587	39.679	119.04	1,562.2	5.913	147.84	492.78	5,913.4
5 (125)	2.494	62.356	187.07	2,454.9	9.293	232.33	774.42	9,293.0
6 (150)	3.602	90.048	270.14	3,545.2	13.42	335.50	1,118.3	13,420
8 (200)	6.237	155.93	467.79	6,138.9	23.24	580.96	1,936.5	23,238
10 (250)	9.831	245.78	737.34	9,676.3	36.63	915.73	3,052.4	36,629
12 (300)	14.10	352.51	1,057.5	13,878	52.54	1,313.4	4,378.0	52,535
14 (350)	16.87	421.71	1,265.1	16,603	62.85	1,571.2	5,237.3	62,848
16 (400)	22.03	550.80	1,652.4	21,685	82.09	2,052.2	6,840.6	82,087
18 (450)	27.89	697.19	2,091.6	27,448	103.90	2,597.6	8,658.6	103,903
20 (500)	34.66	866.51	2,599.5	34,114	129.14	3,228.4	10,761	129,137
24 (600)	50.13	1,253.2	3,759.6	49,339	186.77	4,669.2	15,564	186,769
30 (750)	80.24	2,006.0	6,018.0	78,976	298.96	7,474.0	24,913	298,959
36 (900)	117.40	2,935.0	8,805.1	115,553	437.42	10,935	36,451	437,416

Upstream and downstream piping

To ensure specified accuracy over widely varying process conditions, it is recommended to install the sensor with a minimum of five straight pipe diameters upstream and two pipe diameters downstream from the electrode plane.

Figure 1: Upstream and downstream straight pipe diameters

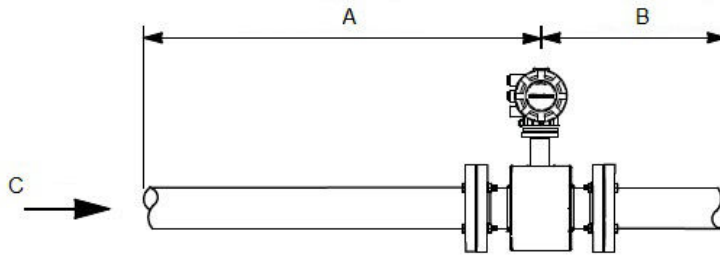

- A. Five pipe diameters (upstream)
- B. Two pipe diameters (downstream)
- C. Flow direction

Installations with reduced upstream and downstream straight runs are possible. In reduced straight run installations, the meter may not meet accuracy specifications. Reported flow rates will still be highly repeatable.

Sensor process reference grounding

In addition to grounding required by applicable safety/electrical standards or codes, a reliable process reference ground path is required between the sensor and the process fluid. Optional grounding rings, process reference electrode, and lining protectors are available with the sensor to ensure proper process reference grounding. See [Table 25](#) and [Table 26](#).

Ordering information

Rosemount 8712EM Transmitter



The Rosemount 8712EM Transmitter with “Best in Class” performance, coupled with advanced diagnostics, provides unparalleled process management capabilities. An optional backlit 2-line by 16-character display/local operator interface is available. The transmitter can be configured using the 15 button tactile keypad.

Note

The starred (★) offerings represent the most common options, and should be selected for best delivery.

Model code structure

Figure 2: Guide to model code structure

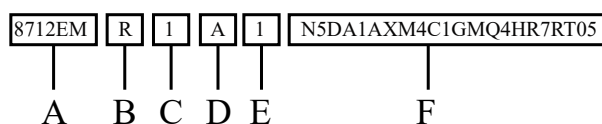

- A. Base model
- B. Mounting style
- C. Power supply
- D. Outputs
- E. Conduit entry
- F. Options ([Table 7](#))

Example model code with one selection out of each category:
8712EM R 1 A 1 N5 DA1 AX M4 C1 GM Q4 HR7 RT05

Table 6: 8712EM requirements - select one from each available choice

Code	Description	
Base model		
8712EM	Magnetic Flowmeter Transmitter - Wall Mount	
Mounting style		
R ⁽¹⁾	Wall Mount	★
Power supply		
1	AC Power Supply (90 - 250 VAC, 50/60 Hz)	★
2	DC Power Supply (12 - 42 VDC)	★

Table 6: 8712EM requirements - select one from each available choice (continued)

Code	Description	
Outputs		
A	4-20 mA Output with Digital HART Protocol & Scalable Pulse Output	★
B ⁽²⁾	4-20 mA Intrinsically Safe Output with Digital Hart Protocol & Intrinsically Safe Scalable Pulse Output	★
F	FOUNDATION Fieldbus Output & Scalable Pulse Output	★
M	Modbus RS-485 & Scalable Pulse Output	★
Conduit entry		
1	½-14 NPT	★
2	M20-1.5 adapters	★

(1) Zn plated CS U-bolt assembly

(2) Intrinsically safe outputs must be externally powered.

Options

Note

The following options are not required, but they must be included in the model number if desired.

Table 7: 8712EM options - select only as needed

Code	Description	
Hazardous area certifications		
-(1)	Ordinary Locations - (no code required)	★
N5	US Approvals, Class I Div 2, Non-Incendive and Dust	★
N6	Canadian Approvals, Class I Div 2, Non-Incendive and Dust	★
ND	ATEX Dust	★
N1 ⁽²⁾	ATEX Non-Sparking, ATEX Dust	★
NF	IECEX Dust	★
N7 ⁽²⁾	IECEX Non-Sparking, IECEX Dust	★
N2 ⁽²⁾	INMETRO Non-Sparking, INMETRO Dust	★
N3 ⁽²⁾	NEPSI Non-Sparking, NEPSI Dust	★
N4 ⁽²⁾	CML Non-Sparking, CML Dust	★
NW ⁽²⁾	PESO Non-Sparking	★
Advanced diagnostics		
DA1	Process Diagnostics, High Process Noise Detection, and Electrode Coating	★
DA2	Smart Meter Verification	★
Discrete input/discrete output		
AX ⁽³⁾	Two Discrete Channels (DI/DO 1, DO 2)	★
Display		
M4 ⁽⁴⁾	LCD with Local Operator Interface	★
M5	LCD Display only	★

Table 7: 8712EM options - select only as needed (continued)

Code	Description	
Miscellaneous		
C1	Custom Configuration (completed CDS form required with order)	
D1 ⁽⁵⁾	High Accuracy Calibration	
B6	316 SST Mounting Bracket with U-bolt Kit for 2-in. Pipe Mount	
Conduit electrical connectors⁽⁶⁾		
GE ⁽⁷⁾	M12, 4-Pin, Male Connector (eurofast [®])	
GM ⁽⁷⁾	A Size Mini, 4-Pin, Male Connector (minifast [®])	
GT ⁽⁸⁾	A Size, Spade Terminal Mini, 5-pin, Male Connector (minifast)	
Quality certificate		
Q4	Calibration Data, per ISO 10474 3.1 / EN 10204 3.1	★
NTEP approval		
WM	US NTEP Certification	★
Revision configuration		
HR7	HART Revision 7	★
Remote cable kit⁽⁹⁾		
RTxx	Standard Temperature Component Cables – -4 °F to 167 °F (-20 °C to 75 °C) For xx: 01 = 10 ft, 02 = 20 ft, 03 = 30 ft, 04 = 40 ft, 05 = 50 ft, 10 = 100 ft, 15 = 150 ft, 20 = 200 ft, 25 = 250 ft, 30 = 300 ft, 35 = 350 ft, 40 = 400 ft, 45 = 450 ft, 50 = 500 ft	★
RHxx	Extended Temperature Component Cables – -58 °F to 257 °F (-50 °C to 125 °C) For xx: 01 = 10 ft, 02 = 20 ft, 03 = 30 ft, 04 = 40 ft, 05 = 50 ft, 10 = 100 ft, 15 = 150 ft, 20 = 200 ft, 25 = 250 ft, 30 = 300 ft, 35 = 350 ft, 40 = 400 ft, 45 = 450 ft, 50 = 500 ft	★
RCxx ⁽¹⁰⁾	Combination Coil and Electrode Cable – -4 °F to 176 °F (-20 °C to 80 °C) For xx: 01 = 10 ft, 02 = 20 ft, 03 = 30 ft, 04 = 40 ft, 05 = 50 ft, 10 = 100 ft, 15 = 150 ft, 20 = 200 ft, 25 = 250 ft, 30 = 300 ft	★
RSxx ⁽¹⁰⁾	Submersible Combination Coil and Electrode Cable – -4 °F to 167 °F/dry, 140 °F wet (-20 °C to 75 °C/dry, 60 °C wet); only available for Ordinary Locations. For xx: 01 = 10 ft, 02 = 20 ft, 03 = 30 ft, 04 = 40 ft, 05 = 50 ft, 10 = 100 ft, 15 = 150 ft, 20 = 200 ft, 25 = 250 ft, 30 = 300 ft	★
Quick Start Guide language		
YF	French	
YG	German	
YI	Italian	
YJ	Japanese	
YM	Chinese–Mandarin	
YP	Portuguese–Brazil	
YR	Russian	
YS	Spanish	

(1) Labeled with CSA(C/US), CE, C-tick and EAC.

(2) DC power only.

(3) Not available with FOUNDATION Fieldbus (output code F).

(4) Not available with FOUNDATION Fieldbus (output code F).

(5) The high accuracy calibration requires a matched sensor. It is only available when ordered with a sensor. Spare or replacement orders are not available with the D1 option.

- (6) *½" NPT conduit entries only*
- (7) *Communication only.*
- (8) *Power and communication.*
- (9) *Remote cable kits are shipped with the transmitter and not connected to the terminals.*
- (10) *Only available for Ordinary Locations.*

Rosemount 8732EM Transmitter



The Rosemount 8732EM Transmitter with “Best in Class” performance, coupled with advanced diagnostics, provides unparalleled process management capabilities. An optional backlit 2-line by 16-character display/local operator interface is available. The transmitter can be configured by optical switches to simplify adjustments in hazardous environments without removing the cover.

Note

The starred (★) offerings represent the most common options, and should be selected for best delivery.

Model code structure

Figure 3: Guide to model code structure

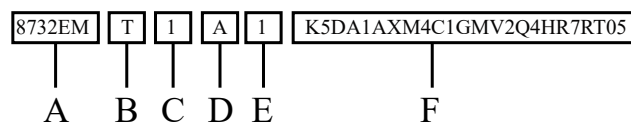

- A. Base model
- B. Mounting style
- C. Power supply
- D. Outputs
- E. Conduit entry
- F. Options ([Table 9](#))

Example model code with one selection out of each category:

8732EM T 1 A 1 K5 DA1 AX M4 C1 GM V2 Q4 HR7 RT05

Requirements

Table 8: 8732EM requirements - select one from each available choice

Code	Description	
Base model		
8732EM	Magnetic Flowmeter Transmitter - Field Mount	★
Mounting style		
T	Integral Field Mount	★
R ⁽¹⁾	Remote Field Mount	★

Table 8: 8732EM requirements - select one from each available choice (continued)

Code	Description	
Power supply		
1	AC Power Supply (90 -250 VAC, 50/60 Hz)	★
2	DC Power Supply (12 - 42 VDC)	★
3 ⁽²⁾	DC Low Power Supply (12 - 30 VDC)	★
Outputs		
A	4-20 mA Output with Digital HART Protocol & Scalable Pulse Output	★
B ⁽³⁾	4-20 mA Intrinsically Safe Output with Digital Hart Protocol & Intrinsically Safe Scalable Pulse Output	★
F	FOUNDATION Fieldbus Output (FISCO) & Scalable Pulse Output	★
M	Modbus RS-485 & Scalable Pulse Output	★
Conduit entry		
1	½-14 NPT — Integral mount qty (2), remote mount qty (4)	★
2	M20-1.5 — Integral mount qty (2), remote mount qty (4)	★
4	½-14 NPT, Additional Entry — Integral mount qty (3), remote mount qty (5)	★
5	M20-1.5, Additional Entry — Integral mount qty (3), remote mount qty (5)	★

(1) *Zn plated CS mounting bolts and 304L bracket.*

(2) *Low Power available for integral mount transmitter with Output B or M only.*

(3) *Intrinsically safe outputs must be externally powered.*

Options

Note

The following options are not required, but they must be included in the model number if desired.

Table 9: 8732EM options - select only as needed

Example code	Category	
Hazardous area certifications		
-(1)	Ordinary Locations - (no code required)	★
N5	US Approvals, Class I Div 2, Non-Incendive and Dust	★
K5	US Approvals, Class I Div 1, Explosion proof and Dust	★
N6	Canadian Approvals, Class I Div 2, Non-Incendive and Dust	★
K6	US/Canadian Approvals, Flameproof with Increased Safety and Dust	★
KU(2)	US Approvals, Class I Div 1, Explosion proof and Dust	★
ND	ATEX Dust	★
N1(3)	ATEX Non-Sparking, ATEX Dust	★
K1	ATEX Flameproof with Increased Safety, ATEX Dust	★
NF	IECEX Dust	★
N7(3)	IECEX Non-Sparking, IECEX Dust	★
K7	IECEX Flameproof with Increased Safety, IECEX Dust	★
N8(3)	EAC Non-Sparking; EAC Dust	★
K8	EAC Flameproof with Increased Safety; EAC Dust	★
N2(3)	INMETRO Non-Sparking, INMETRO Dust	★
K2	INMETRO Flameproof with Increased Safety, INMETRO Dust	★
N3(3)	NEPSI Non-Sparking; NEPSI Dust	★
K3	NEPSI Flameproof with Increased Safety; NEPSI Dust	★
N4(3)	CML Non-Sparking, CML Dust	★
K4	CML Flameproof with Increased Safety, CML Dust	★
K9	KTL Flameproof with Increased Safety, KTL Dust	★
NW(3)	PESO Non-Sparking	★
KW	PESO Flameproof with Increased Safety	★
Advanced diagnostics		
DA1	Process Diagnostics, High Process Noise Detection, and Electrode Coating	★
DA2	Smart Meter Verification	★
Discrete input/discrete output		
AX(4)(5)	Two Discrete Channels (DI/DO 1, DO 2)	★
Display		
M4(5)	Local Operator Interface	★
M5	LCD Display only	★
M6(5)(6)	Local Operator Interface (Polycarbonate lens)	
M7(6)	LCD Display only (Polycarbonate lens)	

Table 9: 8732EM options - select only as needed (continued)

Example code	Category	
Miscellaneous		
C1	Custom Configuration (completed CDS form required with order)	
D1 ⁽⁷⁾	High Accuracy Calibration	
SH ⁽⁸⁾	316 SST Electronics Housing and 316 SST Bracket (Remote mount only)	
B6	316 SST Mounting Bracket with 4-bolt Kit for 2-in. Pipe Mount	
Conduit electrical connectors⁽⁹⁾		
GE ⁽¹⁰⁾	M12, 4-Pin, Male Connector (eurofast [®])	
GM ⁽¹⁰⁾	A Size Mini, 4-Pin, Male Connector (minifast [®])	
GT ⁽¹¹⁾	A Size, Spade Terminal Mini, 5-pin, Male Connector (minifast)	
Paint		
V2	Offshore/Near Shore Marine Paint (3 layer epoxy)	
Quality certificate		
Q4	Calibration Data, per ISO 10474 3.1 / EN 10204 3.1	★
NTEP approval		
WM	US NTEP Certification	★
Revision configuration		
HR7	HART Revision 7	★
Remote cable kit⁽¹²⁾		
RTxx	Standard Temperature Component Cables – -4 °F to 167 °F (-20 °C to 75 °C) For xx: 01 = 10 ft, 02 = 20 ft, 03 = 30 ft, 04 = 40 ft, 05 = 50 ft, 10 = 100 ft, 15 = 150 ft, 20 = 200 ft, 25 = 250 ft, 30 = 300 ft, 35 = 350 ft, 40 = 400 ft, 45 = 450 ft, 50 = 500 ft	★
RHxx	Extended Temperature Component Cables – -58 °F to 257 °F (-50 °C to 125 °C) For xx: 01 = 10 ft, 02 = 20 ft, 03 = 30 ft, 04 = 40 ft, 05 = 50 ft, 10 = 100 ft, 15 = 150 ft, 20 = 200 ft, 25 = 250 ft, 30 = 300 ft, 35 = 350 ft, 40 = 400 ft, 45 = 450 ft, 50 = 500 ft	★
RCxx ⁽¹³⁾	Combination Coil and Electrode Cable – -4 °F to 167 °F (-20 °C to 80 °C) For xx: 01 = 10 ft, 02 = 20 ft, 03 = 30 ft, 04 = 40 ft, 05 = 50 ft, 10 = 100 ft, 15 = 150 ft, 20 = 200 ft, 25 = 250 ft, 30 = 300 ft	★
RSxx ⁽¹³⁾	Submersible Combination Coil and Electrode Cable – -4 °F to 167 °F/dry, 140 °F wet (-20 °C to 75 °C/dry, 60 °C wet); only available for Ordinary Locations. For xx: 01 = 10 ft, 02 = 20 ft, 03 = 30 ft, 04 = 40 ft, 05 = 50 ft, 10 = 100 ft, 15 = 150 ft, 20 = 200 ft, 25 = 250 ft, 30 = 300 ft	★
Quick Start Guide language		
YF	French	
YG	German	
YI	Italian	
YJ	Japanese	
YM	Chinese–Mandarin	
YP	Portuguese–Brazil	
YR	Russian	
YS	Spanish	

(1) Labeled with CSA (C/US), CE, C-tick and EAC.

- (2) *Modbus only.*
- (3) *DC power only.*
- (4) *Only available with conduit entry code 4 or 5.*
- (5) *Not available with FOUNDATION Fieldbus (output code F).*
- (6) *Ordinary Locations only.*
- (7) *The high accuracy calibration requires a matched sensor. It is only available when ordered with a sensor. Spare or replacement orders are not available with the D1 option.*
- (8) *Not available with US/Canadian Approvals N5, K5, N6, or KU.*
- (9) *½" NPT conduit entries only.*
- (10) *Communication only.*
- (11) *Power and communication.*
- (12) *Remote cable kits are shipped with the transmitter and not connected to the terminals.*
- (13) *Only available for Ordinary Locations.*

Rosemount 8705-M Flanged Sensor



All flanged sensors are fabricated from stainless and carbon steel and welded to provide a hermetic seal that protects against moisture and other contaminants. Sizes range from ½-in. (15 mm) to 36-in. (900 mm). The sealed housing ensures maximum sensor reliability by protecting all internal components and wiring from the most hostile environments.

Note

The starred (★) offerings represent the most common options, and should be selected for best delivery.

Model code structure

Figure 4: Guide to model code structure

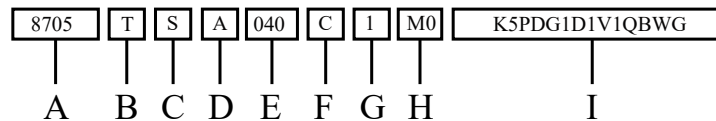

- A. Base model
- B. Lining material
- C. Electrode material
- D. Electrode type
- E. Line size
- F. Flange type and material
- G. Flange rating
- H. Coil housing configuration
- I. Options (Table 11)

Example model code with one selection out of each category: 8705 T S A 040 C 1 M0 K5 PD G1 D1 V1 Q8 WG

Requirements

Table 10: 8705-M Flanged Sensor requirements - select one from each available choice

Code	Description
Base model	
8705	Magnetic Flanged Flowmeter Sensor

Table 10: 8705-M Flanged Sensor requirements - select one from each available choice (continued)

Code	Description	
Lining material - Availability based on line size and flange type/rating. See Table 12 (slip on) and Table 13 (weld neck)		
T	PTFE. Available in line sizes: <ul style="list-style-type: none"> ½-in. to 24-in. (15 mm to 600 mm): ASME Class 150, Class 300, Class 600 (derated), and EN 1092-1 30-in. and 36-in. (750 mm and 900 mm) AWWA Class D, ASME Class 150, and MSS SP44 Class 150 	★
P	Polyurethane. Available in line sizes: <ul style="list-style-type: none"> 1-in. to 24-in. (25 mm to 600 mm) ASME Class 150, Class 300, Class 600 (fully rated) and EN 1092-1 30-in. and 36-in. (750 mm and 900 mm) AWWA Class D and MSS SP44 Class 150 1-in. to 16-in. (25 mm to 400 mm) ASME Class 900 1½-in. to 12-in. (40 mm to 300 mm) ASME Class 1500 Consult Technical Support for ASME Class 2500.	★
N	Neoprene. Available in line sizes: <ul style="list-style-type: none"> 1-in. to 24-in. (25 mm to 600 mm) ASME Class 150, Class 300, Class 600 (fully rated) and EN 1092-1 30-in. and 36-in. (750 mm and 900 mm) AWWA Class D, ASME Class 150, and MSS SP44 Class 150 1-in. to 12-in. (25 mm to 300 mm) ASME Class 900 1½-in. to 12-in. (40 mm to 300 mm) ASME Class 1500 1½-in. to 8-in. (40 mm to 200 mm) ASME Class 2500 	★
L	Linatex - Natural Rubber. Available in line sizes: <ul style="list-style-type: none"> 1-in. to 24-in. (25 mm to 600 mm) ASME Class 150, Class 300, Class 600 (fully rated) and EN 1092-1 30-in. and 36-in. (750 mm and 900 mm) AWWA Class D, ASME Class 150, and MSS SP44 Class 150 1-in. to 12-in. (25 mm to 300 mm) ASME Class 900 1½-in. to 12-in. (40 mm to 300 mm) ASME Class 1500 1½-in. to 8-in. (40 mm to 200 mm) ASME Class 2500 	
A ⁽¹⁾	PFA. Available in line sizes: <ul style="list-style-type: none"> ½-in. to 12-in. (15 mm to 300 mm) ASME Class 150, Class 300, and EN 1092-1 Flanges 14-in. (350 mm) ASME Class 150 	
F	ETFE. Available in line sizes: <ul style="list-style-type: none"> ½-in. to 14-in. (15 mm to 350 mm) ASME Class 150, ASME Class 300, and EN 1092-1 16-in. (400 mm) ASME Class 150 only 1-in. to 10-in. (25 mm to 250 mm) ASME Class 600 (derated) 	
D	Adiprene. Consult technical support for available line sizes.	
K	PFA+. Available in line sizes ½-in. to 14-in. (15 mm to 350 mm) ASME Class 150, Class 300, and EN 1092-1 Flanges.	
Electrode material		
S	316L Stainless Steel	★
H	Nickel Alloy 276 (UNS N10276)	★
T	Tantalum	★
P	80% Platinum - 20% Iridium	★
N	Titanium	★
W	Tungsten-Carbide Coated 316L	
Y	Tungsten-Carbide Coated Nickel Alloy 276	

Table 10: 8705-M Flanged Sensor requirements - select one from each available choice (continued)

Code	Description							
Electrode type								
A	2 Measurement Electrodes - Standard							★
E ⁽²⁾	2 Measurement Electrodes plus 1 Reference Electrode - Standard							★
B ⁽³⁾	2 Measurement Electrodes - Bulletnose							
F ⁽²⁾⁽³⁾	2 Measurement Electrodes plus 1 Reference Electrode - Bulletnose							
T	2 Measurement Electrodes - Flat Head							
U ⁽²⁾	2 Measurement Electrodes plus 1 Reference Electrode - Flat Head							
	Line size	Liner availability In this section, the starred (★) offerings represent available liner based on line size. Consult factory for additional Flange Type/Rating sensor availability						
		PTFE code T	Poly code P	Neo./Lin. codes N/L	PFA code A	ETFE code F	Adiprine code D	PFA+ code K
005	½-in. (15 mm)	★			★	★		★
010	1-in. (25 mm)	★	★	★	★	★		★
015	1½-in. (40 mm)	★	★	★	★	★		★
020	2-in. (50 mm)	★	★	★	★	★	★	★
025	2½-in. (65 mm)	★		★	★	★		★
030	3-in. (80 mm)	★	★	★	★	★	★	★
040	4-in. (100 mm)	★	★	★	★	★	★	★
050	5-in. (125 mm)	★		★	★	★		★
060	6-in. (150 mm)	★	★	★	★	★	★	★
080	8-in. (200 mm)	★	★	★	★	★	★	★
100	10-in. (250 mm)	★	★	★	★	★	★	★
120	12-in. (300 mm)	★	★	★	★	★	★	★
140	14-in. (350 mm)	★	★	★	★	★		★
160	16-in. (400 mm)	★	★	★		★		
180	18-in. (450 mm)	★	★	★				
200	20-in. (500 mm)	★	★	★				
240	24-in. (600 mm)	★	★	★				
300	30-in. (750 mm)	★	★	★				
360	36-in. (900 mm)	★	★	★				
Flange type and material								
C	Slip-On, Raised-Face, Carbon Steel							See Table 12 for Slip-on availability
S	Slip-On, Raised-Face, 304/304L Stainless Steel							
P	Slip-On, Raised-Face, 316/316L Stainless Steel							
F	Slip-On, Flat-Face, Carbon Steel							
G	Slip-On, Flat-Face, 304/304L Stainless Steel							
H	Slip-On, Flat-Face, 316/316L Stainless Steel							

Table 10: 8705-M Flanged Sensor requirements - select one from each available choice (continued)

Code	Description	
D	Weld-Neck, Raised-Face, Carbon Steel	See Table 13 for Weld-neck availability
T	Weld-Neck, Raised-Face, 304/304L Stainless Steel	
R	Weld-Neck, Raised-Face, 316/316L Stainless Steel	
J	Weld-Neck, RTJ, Carbon Steel	
K	Weld-Neck, RTJ, 304/304L Stainless Steel	
L	Weld-Neck, RTJ, 316/316L Stainless Steel	
Flange rating		
1	ASME B16.5, Class 150 (½ thru 24-in.); AWWA Class D (30 and 36-in.)	
2	Class 150 Line Size 30 and 36-in. only; (MSS SP44 with Slip-On Flange or B16.47 Series A with Weld-Neck Flange)	
3	ASME B16.5, Class 300 (½ thru 24-in.); (ASME B16.47 Class 300 for 30 and 36-in. Weld-Neck Flange only)	
6	ASME B16.5, Class 600 (maximum working pressure: derated 1000 psig)	
7	ASME B16.5, Class 600	
9 ⁽⁴⁾	ASME B16.5, Class 900	
M ⁽⁴⁾	ASME B16.5, Class 1500	
N ⁽⁴⁾	ASME B16.5, Class 2500	
D	EN 1092-1, PN10	
E	EN 1092-1, PN16	
F	EN 1092-1, PN25	
H	EN 1092-1, PN40	
K ⁽⁵⁾	AS2129, Table D	
L ⁽⁵⁾	AS2129, Table E	
P ⁽⁶⁾	JIS B 2220, 10K	
R ⁽⁶⁾	JIS B 2220, 20K	
T ⁽⁷⁾	JIS B 2220, 40K	
U ⁽⁸⁾	AS4087, PN16	
W ⁽⁸⁾	AS4087, PN21	
Y ⁽⁸⁾	AS4087, PN35	
Housing configuration		
W0 ⁽⁹⁾⁽¹⁰⁾	Sealed, Welded Housing with Legacy Terminal Block	★
M0 ⁽¹¹⁾	Sealed, Welded Housing	★
M1 ⁽¹¹⁾⁽¹²⁾	Sealed, Welded Housing with Pressure Relief Port	
M2 ⁽¹¹⁾	Sealed, Welded Housing with Sealed Electrode Compartments	
M4 ⁽¹¹⁾	Sealed, Welded Housing with Sealed Electrode Compartments with Cap and Port	

(1) PFA lining material is not available with coil housing codes M2 or M4.

(2) Reference Electrode not available in line sizes ½-in. to 6-in. with M2/M4 coil housing.

(3) Not available in Tantalum - all line sizes; Not available in ½-in. - all materials; Not available in 1-in. with flanges #600 and greater.

(4) Not available with lining protectors.

(5) Not available with PFA (A) liner; not available with lining protectors.

(6) Available line sizes ½-in. to 24-in. (15 mm to 600 mm); not available with lining protectors.

(7) Available line sizes ½-in. to 16-in. (15 mm to 400 mm); not available with lining protectors.

(8) Available in 2-in. to 4-in. (50 mm to 100 mm) and 6-in. to 24-in. (150 mm to 600 mm) line sizes; not available with lining protectors.

- (9) Available for Ordinary Locations or "EN" NEPSI China Domestic Only.
- (10) Consult Product Data Sheet [00813-0100-4727](#) for technical details.
- (11) Consult Technical Support for use with Ordinary Locations.
- (12) Pressure relief valve must be installed appropriately to maintain the approvals on the meter. Recovery piping diameter must not be smaller than M6 to avoid building pressure after the valve.

Options

Note

The following options are not required, but they must be included in the model number if desired.

Table 11: 8705-M Flanged Sensor options - select only as needed

Code	Description	
Hazardous area certifications		
-(1)	Ordinary Locations - (no code required)	★
N5	US Approvals, Class I Div 2, Non-Incendive with I.S. Electrodes; and Dust	★
K5 ⁽²⁾	US Approvals, Class I Div 1, Explosion proof with I.S. Electrodes; and Dust	★
N6	Canadian Approvals, Class I Div 2, Non-Incendive with I.S. Electrodes; and Dust	★
K6	US/Canadian Approvals, Increased Safety with I.S. Electrodes; and Dust	★
KU ⁽²⁾	US Approvals, Class I Div 1, Explosion proof with I.S. Electrodes; and Dust	★
ND	ATEX Dust	★
N1	ATEX Non-Sparking with I.S. Electrodes; ATEX Dust	★
K1	ATEX Increased Safety with I.S. Electrodes; ATEX Dust	★
NF	IECEX Dust	★
N7	IECEX Non-Sparking with I.S. Electrodes; IECEX Dust	★
K7	IECEX Increased Safety with I.S. Electrodes; IECEX Dust	★
N8	EAC Non-Sparking with I.S. Electrodes; EAC Dust	★
K8	EAC Increased Safety with I.S. Electrodes; EAC Dust	★
N2	INMETRO Non-Sparking with I.S. Electrodes; INMETRO Dust	★
K2	INMETRO Increased Safety with I.S. Electrodes; INMETRO Dust	★
N3	NEPSI Non-Sparking with I.S. Electrodes; NEPSI Dust	★
K3	NEPSI Increased Safety with I.S. Electrodes; NEPSI Dust	★
N4	CML Non-Sparking with I.S. Electrodes; CML Dust	★
K4	CML Increased Safety with I.S. Electrodes; CML Dust	★
K9	KTL Flameproof with Increased Safety, KTL Dust	★
NW	PESO Non-Sparking with Intrinsically Safe Electrodes	★
KW	PESO Increased Safety with Intrinsically Safe Electrodes	★
Certifications		
CR	Canadian Registration Number (CRN) Certification	
PD ⁽³⁾	Pressure Equipment Directive Certification (PED)	
DW ⁽⁴⁾	NSF Drinking Water Certification	

Table 11: 8705-M Flanged Sensor options - select only as needed (continued)

Code	Description	
Grounding rings⁽⁵⁾		
G1	(2) 316L SST Ground Rings	
G2	(2) Nickel Alloy 276 (UNS N10276) Ground Rings	
G3	(2) Titanium Ground Rings	
G4	(2) Tantalum Ground Rings	
G5	(1) 316L SST Ground Ring	
G6	(1) Nickel Alloy 276 (UNS N10276) Ground Ring	
G7	(1) Titanium Ground Ring	
G8	(1) Tantalum Ground Ring	
Lining protectors⁽⁶⁾		
L1	(2) 316L SST Lining Protectors	
L2	(2) Nickel Alloy 276 (UNS N10276) Lining Protectors	
L3	(2) Titanium Lining Protectors	
L5	(1) 316L SST Lining Protector	
L6	(1) Nickel Alloy 276 (UNS N10276) Lining Protector	
L7	(1) Titanium Lining Protector	
Miscellaneous		
B3	Integral Mount with 8732EM Transmitter	
D1 ⁽⁷⁾	High Accuracy Calibration (0.15% of rate for matched sensor and transmitter).	
D3	Low Power Calibration	
H1 ⁽⁸⁾	Lay-length matching 8701 using spool piece/spacer	
H2 ⁽⁹⁾	Lay-length matching 8701	
J1 ⁽¹⁰⁾	M20-1.5 Conduit Entries	
P05 ⁽¹¹⁾	Standard Calibration with a 5 Velocity Point Verification Report (1 point each at 2, 4, 6, 8, 10 ft/s)	
SH ⁽¹²⁾	316 SST Coil Housing and Remote Junction Box	
SJ ⁽¹²⁾	316 SST Remote Junction Box	
Increased submergence protection⁽¹³⁾		
S05	Potted junction box with 50 feet of submersible combo cable/cable gland	
S10	Potted junction box with 100 feet of submersible combo cable/cable gland	
S15	Potted junction box with 150 feet of submersible combo cable/cable gland	
S20	Potted junction box with 200 feet of submersible combo cable/cable gland	
S25	Potted junction box with 250 feet of submersible combo cable/cable gland	
S30	Potted junction box with 300 feet of submersible combo cable/cable gland	
Paint		
V1	Coal Tar Paint	
V2	Offshore/Near Shore Marine Paint (3 layer epoxy)	

Table 11: 8705-M Flanged Sensor options - select only as needed (continued)

Code	Description
Quality certificates	
Q4	Calibration Certificate per ISO 10474 3.1/EN 10204 3.1
Q5	Hydrostatic Test Certificate
Q8	Material Traceability per ISO 10474 3.1/EN 10204 3.1
Q25	Certificate of Compliance to NACE MR0175 and MR0103
Q66	Weld Procedure Package (Weld Map, Weld Procedure Specification, Weld Procedure Qualification Record, Welder Performance Qualification)
Q70	NDE Weld Examination Inspection Certificate, ISO 10474 3.1
Q71 ⁽¹⁴⁾	NDE Weld Examination Inspection Certificate, ISO 10474 3.1 with images
Q76	Positive Material Identification (PMI) on flanges and pipe, per ASTM E1476-97
NTEP approval	
WM	US NTEP Certification
Witness inspection	
WG	Witness Inspection
Quick Start Guide language	
YF	French
YG	German
YI	Italian
YJ	Japanese
YM	Chinese–Mandarin
YP	Portuguese–Brazil
YR	Russian
YS	Spanish

(1) Labeled with CSA(C/US), CE, C-tick and EAC.

(2) Available in line sizes ½-in. to 20-in. (15 mm to 500 mm), **excluding** 2½-in. (65 mm) and 5-in. (125 mm) line sizes.

(3) Carbon Steel flanges for PED have a minimum process temperature limit of 0 °C.

(4) Available liners PTFE (T) all line sizes or Polyurethane (P) 4-in. or larger; electrode materials 316L SST (S) or Ni-Alloy 276 (H).

(5) Grounding Rings and Lining Protectors provide the same process reference function.

(6) Grounding Rings and Lining Protectors provide the same process reference function.

(7) The high accuracy calibration requires a matched transmitter. It is only available when ordered with a transmitter. Spare or replacement orders are not available with the D1 option.

(8) Available line sizes ½ -in. to 12-in. (15 mm to 300 mm).

(9) Available in sensor line sizes ½ -in. to 16-in. (15 mm to 400 mm).

(10) M20 conduit adapters are supplied for Ordinary Locations and US/Canadian Approvals N5, N6, K5 and KU.

(11) Available for: ½-in. to 24-in. (15 mm to 600 mm) Velocities 2, 4, 6, 8, 10 ft/s; 30-in. (700 mm) Velocities 1, 2, 3, 4, 6, 8 ft/s; 36-in. (900 mm) Velocities 1, 2, 3, 4, 5, 6 ft/s.

(12) Not available with US/Canadian Approvals N5, K5, N6, or KU.

(13) Ordinary location only. Conduit not required.

(14) Weld-Neck only.

Slip-on flanges

Table 12: Slip on flange options by line size

Size code	Flange code and rating																	
	1	2	3	6	7	9	D	E	F	H	K	L	P	R	T	U	W	Y
	ASME Class 150	MSS-SP44 Class 150 (30", 36")	ASME Class 300	ASME Class 600 Derated	ASME Class 600 Full Rated	ASME Class 900	EN PN10	EN PN16	EN PN25	EN PN40	AS2129 Table D	AS2129 Table E	JIS 10K	JIS 20K	JIS 40K	AS4087 PN16	AS4087 PN21	AS4087 PN35
005	★		★	★	★					★	★	★	★	★	★			
010	★		★	★	★	★				★	★	★	★	★	★			
015	★		★	★	★	★				★	★	★	★	★	★			
020	★		★	★	★	★		★		★	★	★	★	★	★	★	★	★
025	★		★	★	★	★		★		★	★	★	★	★	★	★	★	★
030	★		★	★	★	★		★		★	★	★	★	★	★	★	★	★
040	★		★	★	★	★		★		★	★	★	★	★	★	★	★	★
050	★		★	★	★	★		★		★	★	★	★	★	★			
060	★		★	★	★	★		★	★	★	★	★	★	★	★	★	★	★
080	★		★	★	★	★	★	★	★	★	★	★	★	★	★	★	★	★
100	★		★	★	★	★	★	★	★	★	★	★	★	★	★	★	★	★
120	★		★	★	★	★	★	★	★	★	★	★	★	★	★	★	★	★
140	★		★	★	★	★	★	★	★	★	★	★	★	★	★	★	★	★
160	★		★	★	★	★	★	★	★	★	★	★	★	★	★	★	★	★
180	★		★	★	★	★	★	★	★	★	★	★	★	★		★	★	★
200	★		★	★	★	★	★	★	★	★	★	★	★	★		★	★	★
240	★		★	★	★		★	★	★	★	★	★	★	★		★	★	★
300	★ ⁽¹⁾	★	★								★	★				★	★	★
360	★ ⁽¹⁾	★	★				★	★			★	★				★	★	★

(1) AWWA Class D

Weld neck flanges

Table 13: Weld neck flange options by line size

Size code	Flange code and rating											
	1	2	3	6	7	9	D	E	F	H	M	N
	ASME Class 150	ASME Class 150 (30", 36")	ASME Class 300	ASME Class 600 Derated	ASME Class 600 Full Rated	ASME Class 900	EN PN10	EN PN16	EN PN25	EN PN40	ASME Class 1500	ASME Class 2500
005	★		★							★		
010	★		★	★	★	★				★	★	
015	★		★	★	★	★				★	★	★
020	★		★	★	★	★				★	★	★
025											★	★
030	★		★	★	★	★				★	★	★
040	★		★	★	★	★		★		★	★	★
050												
060	★		★	★	★	★		★	★	★	★	★
080	★		★	★	★	★	★	★	★	★	★	★
100	★		★	★	★	★	★	★	★	★	★	
120	★		★	★	★	★	★	★	★	★	★	
140	★		★	★	★	★	★	★	★	★		
160	★		★	★	★	★	★	★	★	★		
180	★		★	★	★	★	★	★	★	★		
200	★		★	★	★	★	★	★	★	★		
240	★		★	★	★		★	★	★	★		
300		★ ⁽¹⁾	★ ⁽¹⁾									
360		★ ⁽¹⁾	★ ⁽¹⁾				★	★	★			

(1) ASME B16.47 Series A.

Rosemount 8711-M/L Wafer Sensors



The flangeless design of the wafer sensor makes it an economical, compact, and lightweight alternative to flanged magnetic flowmeters. Alignment spacers are provided with every 8711-M/L which help center the sensor in the process line simplifying installation.

Note

The starred (★) offerings represent the most common options, and should be selected for best delivery.

Model code structure

Figure 5: Guide to model code structure

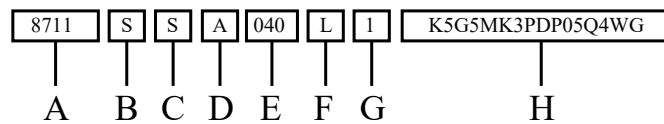

- A. Base model
- B. Lining material
- C. Electrode material
- D. Electrode type
- E. Line size
- F. Transmitter mounting configuration
- G. Mating pipe flange pressure rating
- H. Options ([Table 15](#))

Example model code with one selection out of each category: 8711 S S A 040 L 1 K5 G5 MK3 PD P05 Q4 WG

Requirements

Table 14: Rosemount 8711-M/L Wafer Sensor requirements – select one from each available choice

Code	Product description	
Base model		
8711	Rosemount Wafer Sensor	
Wafer Sensor lining material		
A ⁽¹⁾	PFA	
S	PTFE	★
F	ETFE	

Table 14: Rosemount 8711-M/L Wafer Sensor requirements - select one from each available choice (continued)

Code	Product description	
Electrode material		
S	316L Stainless Steel	★
H	Nickel Alloy 276 (UNS N10276)	★
T	Tantalum	★
P	80% Platinum - 20% Iridium	★
N	Titanium	★
Electrode type		
A	2 Measurement Electrodes	★
E	2 Measurement Electrodes plus 1 Reference Electrode	
B ⁽²⁾	2 Bulletnose Measurement Electrodes	
F ⁽²⁾	2 Measurement Bulletnose Electrodes plus 1 Reference Bulletnose Electrode	
8711-R/U line size		
15F	0.15-in. (4 mm) liner material PFA only; mounting configuration R/U only	★
30F	0.30-in. (8 mm) liner material PFA only; mounting configuration R/U only	★
005	½-in. (15 mm); mounting configuration R/U only	★
010	1-in. (25 mm); mounting configuration R/U only	★
8711-M/L line size		
015	1½-in. (40 mm)	
020	2-in. (50 mm)	
030	3-in. (80 mm)	
040	4-in. (100 mm)	
060	6-in. (150 mm)	
080	8-in. (200 mm)	
Transmitter mounting configuration		
R ⁽³⁾ (4)	Remote Mount with Legacy Terminal Block	
U ⁽³⁾ (4)	Integral Mount IMS Cable Assembly for use with an 8732EM Transmitter	
L	Remote Mount with Field Replaceable Terminal Block	
M ⁽⁵⁾	Integral Mount Socket Module/Direct Lead Assembly for use with an 8732EM Transmitter	

Table 14: Rosemount 8711-M/L Wafer Sensor requirements - select one from each available choice (*continued*)

Code	Product description
Mating pipe flange pressure rating - Includes three alignment spacers (where applicable)	
1	ASME, Class 150
3	ASME, Class 300
D	EN1092-1, PN10
E	EN1092-1, Flange Rating up to PN16
F	EN1092-1, Flange Rating up to PN25
H	EN1092-1, Flange Rating up to PN40
P	JIS B2220, 10K
R	JIS B2220, 20K
U	AS4087, PN16
W	AS4087, PN21
Y	AS4087, PN35

(1) Available for 15F, 30F only.

(2) not available in 0.15-in., 0.3-in., or ½-in. line sizes.

(3) Available for Ordinary Locations, "EN" NEPSI China Domestic, "KD" ATEX, "N5," CSA (C/US) or "E5" CSA (C/US) only.

(4) Reference Product Data Sheet [00813-0100-4727](#) for technical details.

(5) Consult Technical Support for use with Ordinary Locations.

Options

Note

The following options are not required, but they must be included in the model number if desired.

Table 15: Rosemount 8711-M/L Wafer Sensor options - select only as needed

Code	Description	
Hazardous area certifications		
-(1)	Ordinary Locations - (no code required)	★
N5	US Approvals, Class I Div 2, Non-Incendive with I.S. Electrodes; and Dust	★
K5	US Approvals, Class I Div 1, Explosion proof with I.S. Electrodes; and Dust	★
N6	Canadian Approvals, Class I Div 2, Non-Incendive with I.S. Electrodes; and Dust	★
K6	US/Canadian Approvals, Increased Safety with I.S. Electrodes; and Dust	★
KU	US Approvals, Class I Div 1, Explosion proof with I.S. Electrodes; and Dust	★
ND	ATEX Dust	★
N1	ATEX Non-Sparking with I.S. Electrodes; ATEX Dust	★
K1	ATEX Increased Safety with I.S. Electrodes; ATEX Dust	★
NF	IECEX Dust	★
K9	KTL Flameproof with Increased Safety, KTL Dust	★
N7	IECEX Non-Sparking with I.S. Electrodes; IECEX Dust	★
K7	IECEX Increased Safety with I.S. Electrodes; IECEX Dust	★
N8	EAC Non-Sparking with I.S. Electrodes; EAC Dust	★
K8	EAC Increased Safety with I.S. Electrodes; EAC Dust	★
N2	INMETRO Non-Sparking with I.S. Electrodes; INMETRO Dust	★
K2	INMETRO Increased Safety with I.S. Electrodes; INMETRO Dust	★
N3	NEPSI Non-Sparking with I.S. Electrodes; NEPSI Dust	★
K3	NEPSI Increased Safety with I.S. Electrodes; NEPSI Dust	★
N4	CML Non-Sparking with I.S. Electrodes; CML Dust	★
K4	CML Increased Safety with I.S. Electrodes; CML Dust	★
NW	PESO Non-Sparking with Intrinsically Safe Electrodes	★
KW	PESO Increased Safety with Intrinsically Safe Electrodes	★
Increased submergence protection⁽²⁾		
S05	Potted junction box with 50 feet of submersible combo cable/cable gland	
S10	Potted junction box with 100 feet of submersible combo cable/cable gland	
S15	Potted junction box with 150 feet of submersible combo cable/cable gland	
S20	Potted junction box with 200 feet of submersible combo cable/cable gland	
S25	Potted junction box with 250 feet of submersible combo cable/cable gland	
S30	Potted junction box with 300 feet of submersible combo cable/cable gland	

Table 15: Rosemount 8711-M/L Wafer Sensor options - select only as needed (continued)

Code	Description
Grounding rings	
G1	(2) 316L SST Ground Rings
G2	(2) Nickel Alloy 276 (UNS N10276) Ground Rings
G3	(2) Titanium Ground Rings
G4	(2) Tantalum Ground Rings
G5	(1) 316L SST Ground Ring
G6	(1) Nickel Alloy 276 (UNS N10276) Ground Ring
G7	(1) Titanium Ground Ring
G8	(1) Tantalum Ground Ring
Mounting hardware	
MK2	Carbon Steel mounting Studs & Nuts Kit
MK3	316 SST mounting Studs & Nuts Kit
Certifications	
PD	Pressure Equipment Directive Certification (PED)
DW ⁽³⁾	NSF Drinking Water Certification
Other options	
D1 ⁽⁴⁾	High Accuracy Calibration (0.15% of rate for matched sensor and transmitter)
J1 ⁽⁵⁾	M20-1.5 Conduit Entries
SJ ⁽⁶⁾	316 SST Remote Junction Box
P05	Standard Calibration with a 5 Velocity Point Verification Report (1 point each at 2, 4, 6, 8, 10 ft/s)
Quality certificates	
Q4	Calibration Certificate per ISO 10474 3.1 / EN 10204 3.1
Q5	Hydrostatic Test Certificate
Q8	Material Traceability per ISO 10474 3.1 / EN 10204 3.1
Q25	Certificate of Compliance to NACE MR0175 and MR0103
Q66 ⁽⁷⁾	Weld Procedure Package (Weld Map, Weld Procedure Specification, Weld Procedure Qualification Record, Welder Performance Qualification)
Q70 ⁽⁷⁾	NDE Weld Examination Inspection Certificate, ISO 10474 3.1
Q76 ⁽⁷⁾	Positive Material Identification (PMI) on Pipe, per ASTM E1476-97
Witness inspection	
WG	Witness Inspection
Quick Start Guide language	
YF	French
YG	German
YI	Italian

Table 15: Rosemount 8711-M/L Wafer Sensor options - select only as needed *(continued)*

Code	Description
YJ	Japanese
YM	Chinese-Mandarin
YP	Portuguese-Brazil
YR	Russian
YS	Spanish

- (1) *Labeled with CSA (C/US), CE, C-tick and EAC.*
- (2) *Ordinary location only, line sizes 1½-in. (40 mm) to 8-in. (200 mm). Conduit not required.*
- (3) *Available liner PTFE (T) and electrode materials 316L SST (S) or Ni-Alloy 276 (H).*
- (4) *The high accuracy calibration requires a matched transmitter. It is only available when ordered with a transmitter. Spare or replacement orders are not available with the D1 option.*
- (5) *M20 conduit adapters are supplied for Ordinary Locations and US/Canadian Approvals N5, N6, K5 and KU.*
- (6) *Not available with US/Canadian Approvals N5, N6, K5, or KU.*
- (7) *Available on 6- and 8-in. only.*

Rosemount 8721 Hygienic (Sanitary) Sensor



The 8721 Hygienic Sensor is specifically designed for the demanding applications in food, beverage, and life sciences. The robust, all-welded, full diameter sensor is constructed of FDA approved materials, authorized to display the 3-A Symbol (Authorization #1222). Sizes range from ½-in. (15mm) to 4-in. (100mm) and are available in a variety of industry standard process connections.

Note

The starred (★) offerings represent the most common options, and should be selected for best delivery.

Model code structure

Figure 6: Guide to model code structure

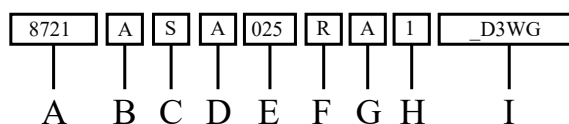

- A. Base model
- B. Lining material
- C. Electrode material
- D. Electrode type
- E. Line size
- F. Transmitter mounting configuration
- G. Process connection type
- H. Process gasket material
- I. Options ([Table 17](#))

Example model code with one selection out of each category: 8721 A S A 025 R A 1 _ D3 WG

Requirements

Table 16: Rosemount 8721 Hygienic Sensor Requirements - select one from each available choice

Model	Product description
Base model	
8721	Rosemount Hygienic Sensor
Lining material	
A	PFA ★

Table 16: Rosemount 8721 Hygienic Sensor Requirements - select one from each available choice (continued)

Model	Product description	
Electrode material		
S	316L SST	★
H	Nickel Alloy 276 (UNS N10276)	★
P	80% Platinum-20% Iridium	
Electrode type		
A	2 Measurement Electrodes	★
Line size		
005	½-in. (15 mm)	★
010	1-in. (25 mm)	★
015	1½-in. (40 mm)	★
020	2-in. (50 mm)	★
025	2½-in. (65 mm)	★
030	3-in. (80 mm)	★
040	4-in. (100 mm)	★
Transmitter mounting configuration		
R	Remote Mount with Replaceable Terminal Block	★
U	Integral mount	★
Process connection type		
A ⁽¹⁾	Tri Clamp	★
B ⁽²⁾	IDF Sanitary screw type	★
C	ANSI Weld Nipple	
D	DIN 11851 (Imperial)	
E	DIN 11851 (Metric)	
F	DIN 11864-1 form A	
G	DIN 11864-2 form A	
H	SMS Connection	
J	Cherry-Burrell I-Line	
K	DIN 11850 Weld Nipple	
Gasket material		
1	Silicone	★
2	EPDM	★
4	Viton®	
8	EPDM Compression limiting ⁽³⁾	
9	Viton Compression limiting ⁽³⁾	
X	No Gasket - User Supplied (Order gasket kit as a spare part)	

(1) Tri Clamp specification per BPE ½-inch (15 mm) line size with Tri Clamp fittings use a ¾-inch fitting and requires ¾-inch gaskets.

(2) IDF Specification per BS4825 Part 4.

(3) Compression limiting gasket required for EHEDG.

Options

Note

The following options are not required, but they must be included in the model number if desired.

Table 17: Rosemount 8721 Hygienic Sensor options - select only as needed

Model	Product description	
-(¹)	Ordinary Locations - (no code required)	★
Other options		
AH	Electro-Polished process connection (Ra ≤ 15µinch)	
D1(²)	High Accuracy Calibration (0.25% of rate for matched sensor and transmitter system)	
D3	High Velocity Meter Verification. Calibration verified at 1, 3, 10 and 20 ft/sec (0.3, 1, 3, and 6 m/s)	
HP	Process Data PD340 (Alfa-Laval PD340) 250mm lay length and Tri Clamp process connections	
J1	M20-1.5 Conduit Adapter (Remote mount only)	
Q4	Calibration Certificate per ISO 10474 3.1/ EN 10204 3.1	
Q8	Material Traceability Certificate per ISO 10474 3.1 / EN 10204 3.1(product contact surfaces)	
SJ	316 SST Remote Junction Box	
NTEP approval		
WM	US NTEP Certification	
Witness inspection		
WG	Witness inspection	
Quick Start Guide language		
YF	French	
YG	German	
YI	Italian	
YM	Chinese-Mandarin	
YP	Portuguese-Brazil	
YR	Russian	
YS	Spanish	

(1) Labeled with CSA (C/US), CE, C-tick and EAC.

(2) The high accuracy calibration requires a matched transmitter. It is only available when ordered with a transmitter. Spare or replacement orders are not available with the D1 option.

Rosemount 8714D Magnetic Flowmeter Simulator Reference Calibration Standard



The Rosemount 8714D Magnetic Flowmeter Simulator attaches to an 8732EM Transmitter’s sensor connections to ensure traceability to NIST standards and long-term accuracy of the flowmeter system.

Note

The starred (★) offerings represent the most common options, and should be selected for best delivery.

Table 18: Rosemount 8714 Ordering Information

Model	Product	
8714	Magnetic Flowmeter Simulator - Reference Calibration Standard	★
Calibrator style		
D	Multi-point Reference Calibration Standard	★
Quality certificates		
Q4	Flow Calibration Certificate	★
Quick Start Guide language		
YF	French	★
YG	German	★
YI	Italian	★
YM	Chinese-Mandarin	★
YP	Portuguese-Brazil	★
YR	Russian	★
YS	Spanish	★

Ordering flowmeter equipment

Ordering procedure

To order, select the desired sensor and/or transmitter by specifying model codes from the ordering table.

For remote transmitter applications, note the cable specification requirements.

Sensors and transmitters must be selected from Product Data Sheet [00813-0100-4444](#), unless otherwise noted.

Standard configuration

Unless the Configuration Data Sheet is completed, the transmitter will be shipped as follows:

Engineering units:	ft/sec
4mA:	0
20mA:	30
Sensor size:	3-in.
Empty pipe:	On
Sensor calibration number:	1000005010000000

Integrally mounted transmitters are factory configured with the paired sensor size and appropriate calibration number.

Custom configuration (option code C1)

If Option Code C1 is ordered, the Configuration Data Sheet (CDS) must be submitted at the time of order.

Standard tagging

Instrument tags for the transmitter and sensors are as follows:

- 316SST laser etched label, permanently attached
- Main label:

Model string	8712EM: character height 0.060 in. (1.5 mm) 8732EM: character height 0.085 in. (2.1 mm) 8705, 8711, 8721: character height 0.065 in. (1.6 mm)
Tag name	1 line 21 characters, height 0.065 in. (1.6 mm)

- Additional 316SST 'wire-on' tag available: 5 lines, 17 characters per line (3.2 mm height)

Interconnecting cable

Interconnecting cables are required to connect a remote mount transmitter to the sensor. When ordering cable, review the hazardous area approval requirements and the installation location requirements for proper cable selection.

- Cables can be ordered as individual component cables or a combination coil drive/electrode cable.
- Cables can be ordered as part of the transmitter model number or as a spare parts kit. Integrally mounted transmitters are factory wired and do not require additional interconnecting cables.
- Individual component cables require equal lengths of coil drive cable and electrode cable and should be limited to less than 500 feet (152 m). Consult an Emerson Flow representative for lengths between 500-1000 feet (152-300 m).
- Combination coil drive/electrode cable is only available for Ordinary Locations and should be limited to less than 330 feet (100 m).

Component cable kits

Standard temperature – -4 °F to 167 °F (-20 °C to 75 °C)				
Cable kit #	Description	Component	Alpha direct p/n	Alpha equivalent
08732-0065-0001 (feet)	Kit, Component Cables, Std Temp, (includes Coil and Electrode)	Coil	518243	2442C
		Electrode	518245	2413C
08732-0065-0002 (meters)	Kit, Component Cables, Std Temp (includes Coil and Electrode)	Coil	Not available	Not available
		Electrode	Not available	Not available
08732-0065-0003 (feet)	Kit, Component Cables, Std Temp (includes Coil and I. S. Electrode)	Coil	518243	Not available
		I. S. Electrode	518244	Not available
08732-0065-0004 (meters)	Kit, Component Cables, Std Temp (includes Coil and I. S. Electrode)	Coil	Not available	Not available
		I.S. Electrode	Not available	Not available

Extended temperature – -58 °F to 257 °F (-50 °C to 125 °C)				
Cable kit #	Description	Component	Alpha direct p/n	Alpha equivalent
08732-0065-1001 (feet)	Kit, Component Cables, Ext Temp (includes Coil and Electrode)	Coil	840310	Not available
		Electrode	518189	Not available
08732-0065-1002 (meters)	Kit, Component Cables, Ext Temp (includes Coil and Electrode)	Coil	Not available	Not available
		Electrode	Not available	Not available
08732-0065-1003 (feet)	Kit, Component Cables, Ext Temp (includes Coil and I. S. Electrode)	Coil	840310	Not available
		I. S. Electrode	840309	Not available
08732-0065-1004 (meters)	Kit, Component Cables, Ext Temp (includes Coil and I. S. Electrode)	Coil	Not available	Not available
		I.S. Electrode	Not available	Not available

Combo cable kits

Coil/electrode cable – -4 °F to 176 °F (-20 °C to 80 °C)	
Cable Kit # ⁽¹⁾	
08732-0065-2001 (feet)	Kit, Combo Cable, Standard
08732-0065-2002 (meters)	
08732-0065-3001 (feet)	Kit, Combo Cable, Submersible ⁽²⁾
08732-0065-3002 (meters)	

(1) Only available for Ordinary Locations.

(2) 80 °C dry/60 °C wet/33 ft continuous submergence.

Product specifications

Rosemount 8700M Flowmeter Platform specifications

The tables below outline some of the basic performance, physical, and functional specifications of the Rosemount 8700M Magnetic Flowmeter Platform.

Table 19: Rosemount 8712EM Transmitter Specifications

	Model	8712EM
	Base accuracy ⁽¹⁾	0.25% Standard 0.15% High Accuracy Option
	Mounting	Remote
	Power supply	Global AC or DC
	User interface	LCD display with 15 button tactile keypad (with HART or Modbus protocols only) LCD display only No display
	Communication protocol	HART FOUNDATION™ fieldbus Modbus RS-485
	Diagnostics	Basic, DA1, DA2
	Sensor compatibility	All Rosemount plus other manufacturers
	Detailed specifications	8712 and 8732 Transmitter specifications
	Ordering information	Ordering information



(1) For complete accuracy specifications, please refer to [Transmitter functional specifications](#).

Table 20: Rosemount 8732EM Transmitter Specifications

	Model	8732EM
	Base accuracy ⁽¹⁾	0.25% Standard 0.15% High Accuracy Option
	Mounting	Integral or Remote
	Power supply	Global AC or DC
	User interface	LCD display with 4 Optical Switch LOI (with HART or Modbus protocols only) LCD display only No display
	Communication protocol	HART FOUNDATION™ fieldbus Modbus RS-485
	Diagnostics	Basic, DA1, DA2
	Sensor compatibility	All Rosemount plus other manufacturers
	Detailed specifications	8712 and 8732 Transmitter specifications
	Ordering information	Ordering information

(1) For complete accuracy specifications, please refer to [Transmitter functional specifications](#).

Table 21: Rosemount Sensor Specifications

8705 Sensor		
	Style	Flanged
	Base accuracy ⁽¹⁾	0.25% Standard 0.15% High Accuracy Option
	Line sizes	½-in. to 36-in. (15 mm to 900 mm)
	Design features	Standard Process Design
	Detailed specifications	8705-M Flanged Sensor Specifications
	Ordering information	Rosemount 8705-M Flanged Sensor
8711 Sensor		
	Style	Wafer
	Base accuracy ⁽¹⁾	0.25% Standard 0.15% High Accuracy Option
	Line sizes	1½ -in. to 8-in. (40 mm to 200 mm)
	Design features	Compact, Light Weight
	Detailed specifications	8711-M/L Wafer Sensor Specifications
	Ordering information	Rosemount 8711-M/L Wafer Sensors
8721 Sensor		
	Style	Hygienic (sanitary)
	Base accuracy ⁽¹⁾	0.5% Standard 0.25% High Accuracy Option
	Line sizes	½-in. to 4-in. (15 mm to 100 mm)
	Design features	3-A CIP/SIP
	Detailed specifications	8721 Hygienic (Sanitary) Sensor Specifications
	Ordering information	Rosemount 8721 Hygienic (Sanitary) Sensor

(1) For complete accuracy specifications, refer to the sensor's detailed specifications.

Table 22: Lining Material Selection



Liner material	General characteristics
PFA, PFA+ 	Best chemical resistance
	Better abrasion resistance than PTFE
	Best high temperature capabilities
	Process temperature: -58 to 350 °F (-50 to 177 °C)
PTFE 	Highly chemical resistant
	Excellent high temperature capabilities
	Process temperature: -58 to 350 °F (-50 to 177 °C)

Table 22: Lining Material Selection (continued)



Liner material	General characteristics
ETFE 	Excellent chemical resistance
	Better abrasion resistance than PTFE
	Process temperature: -58 to 300 °F (-50 to 149 °C)
Polyurethane 	Limited chemical resistance
	Excellent abrasion resistance for slurries with small and medium particles
	Process temperature: 0 to 140 °F (-18 to 60 °C)
	Typically applied in clean water
Neoprene 	Very good abrasion resistance for small and medium particles
	Better chemical resistance than polyurethane
	Typically applied in water with chemicals, and sea water
	Preferred liner for high pressure > ASME B16.5 Class 900
	Process temperature: 0 to 176 °F (-18 to 80 °C)
Linatex Rubber 	Limited chemical resistance especially in acids
	Very good abrasion resistance for large particles
	Softer material than polyurethane and neoprene
	Typically applied in mining slurries
	Process temperature: 0 to 158 °F (-18 to 70 °C)
Adiprene 	Ideal for applications with high salinity and/or hydrocarbon carryover
	Excellent abrasion resistance
	Typically used for Water Injection, Recovered Water, and Coal Gasification Slurries
	Preferred liner for high pressure > ASME B16.5 Class 900
	Process temperature: 0 to 200 °F (-18 to 93 °C)

Table 23: Electrode Material

Electrode material	General characteristics
316L Stainless Steel	Good corrosion resistance
	Good abrasion resistance
	Not recommended for sulfuric or hydrochloric acids
Nickel Alloy 276 (UNS N10276)	Better corrosion resistance
	High strength
	Good in slurry applications
	Effective in oxidizing fluids
Tantalum	Excellent corrosion resistance
	Not recommended for hydrofluoric acid, fluorosilic acid, or sodium hydroxide

Table 23: Electrode Material (continued)

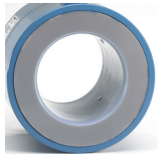
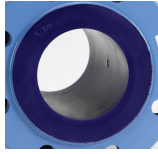
Electrode material	General characteristics
80% Platinum 20% Iridium	Best chemical resistance
	Expensive material
	Not recommended for aquaregia
Titanium	Better chemical resistance
	Better abrasion resistance
	Good for sea water applications
	Not recommended for hydrofluoric or sulfuric acid
Tungsten Carbide coated	Limited chemical resistance
	Best abrasion resistance
	High concentration slurries
	Preferred electrode for oil and gas fracturing applications

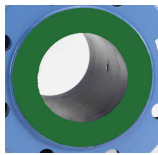
Table 24: Electrode Type

Electrode type	General characteristics
Standard Measurement	Lowest cost
	Good for most applications
Measurement + Reference Electrode (Also see Table 25 and Table 26 for grounding options and installation)	Low cost grounding option especially for large line sizes
	If using a reference electrode, process fluid must have a minimum conductivity of 100 microSiemens/cm
	Not recommended for electrolytic or galvanic corrosion applications
Bulletonose	Extended head protrudes into the flow stream for self-cleaning
	Best option for coating processes
Flat Head	Low profile head
	Best option for abrasive slurries

Table 25: Process Reference Options

Grounding options	General characteristics
No Grounding Options (grounding straps)	Acceptable for conductive unlined pipe
	Grounding straps provided at no cost
Reference Electrode	Same material as measurement electrodes
	Sufficient grounding option when process fluid conductivity is greater than 100 microSiemens/cm
	Not recommended in electrolysis applications, galvanic corrosion applications, applications where the electrodes may coat, or non-conductive pipe.
Grounding Rings	Low conductivity process fluids
	Cathodic or electrolysis applications that may have stray currents in or around the process
	Variety of materials for process fluid compatibility

Table 25: Process Reference Options (continued)

Grounding options	General characteristics
Lining Protectors	Protect upstream edge of sensor from abrasive fluids
	Permanently installed on sensor
	Protect liner material from over torquing of flange bolts
	Provide ground path and eliminate need for grounding rings or reference electrode
	Required for applications where Flexitallic gaskets are used

Table 26: Process Reference Installation

Type of pipe	Grounding straps	Grounding rings	Reference electrode	Lining protectors
Conductive unlined pipe	Acceptable	Not required	Not required	Not required
Conductive lined pipe	Not acceptable	Acceptable	Acceptable	Acceptable
Non-conductive pipe	Not acceptable	Acceptable	Not recommended	Acceptable

8712 and 8732 Transmitter specifications

Transmitter functional specifications

Sensor compatibility

Compatible with Rosemount 8705, 8711, and 8721 sensors. Compatible with AC and DC powered sensors of other manufacturers.

Transmitter coil drive current

500mA

Flow rate range

Capable of processing signals from fluids with velocities between 0.04 and 39 ft/s (0.01 to 12 m/s) for both forward and reverse flow in all sensor sizes. Full scale continuously adjustable between -39 and 39 ft/s (-12 to 12 m/s).

Conductivity limits

Process liquid must have a conductivity of 5 microSiemens/cm (5 micromhos/cm) or greater.

Power supply

- 90 - 250 VAC @ 50/60 Hz
- 12 - 42 VDC
- 12 - 30 VDC (with HART or Modbus protocol only)

Line power fuses

- 90 - 250 VAC systems:
 - 2 amp quick acting
 - Bussman AGC2 or equivalent
- 12 - 42 VDC systems
 - 3 amp quick acting
 - Bussman AGC3 or equivalent
- 12 - 30 VDC systems
 - 3 amp quick acting
 - Bussman AGC3 or equivalent

Power consumption

- 90 - 250 VAC: 40 VA maximum
- 12 - 42 VDC: 15 W maximum
- 12 - 30 VDC: 3 W maximum HART
- 12 - 30 VDC: 4 W maximum Modbus

Switch-on current

- At 250 VAC: Maximum 35.7 A (< 5 ms)
- At 42 VDC: Maximum 42 A (< 5 ms)
- At 30 VDC: Maximum 42 A (< 5 ms)

AC power supply requirements

Units powered by 90 - 250 VAC have the following power requirements. Peak inrush is 35.7 A at 250 VAC supply, lasting approximately 1ms. Inrush for other supply voltages can be estimated with: $\text{Inrush (Amps)} = \text{Supply (Volts)} / 7.0$

Figure 7: AC current requirements

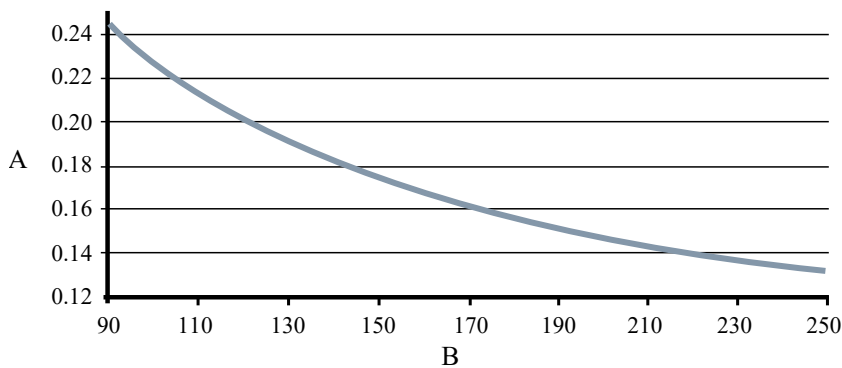

- A. Supply current (amps)
- B. Power supply (VAC)

Figure 8: Apparent power

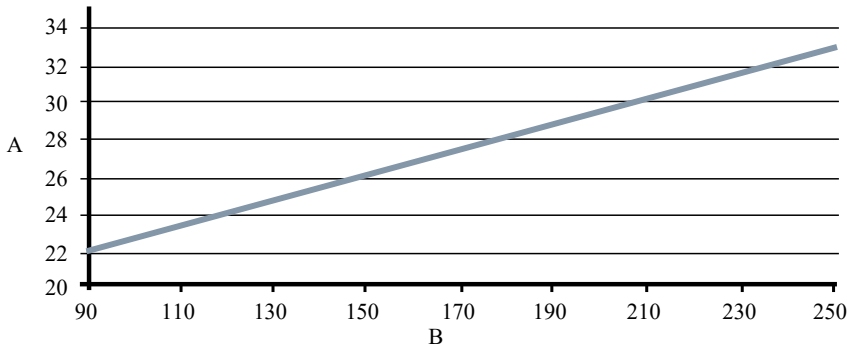

- A. Apparent power (VA)
- B. Power supply (VAC)

DC power supply requirements

Standard DC Units powered by 12 VDC power supply may draw up to 1.2 A of current steady state. Low power DC units may draw up to 0.25 A of current steady state. Peak inrush is 42 A at 42 VDC supply, lasting approximately 1 ms. Inrush for other supply voltages can be estimated with: $\text{Inrush (Amps)} = \text{Supply (Volts)} / 1.0$

Figure 9: DC current requirements

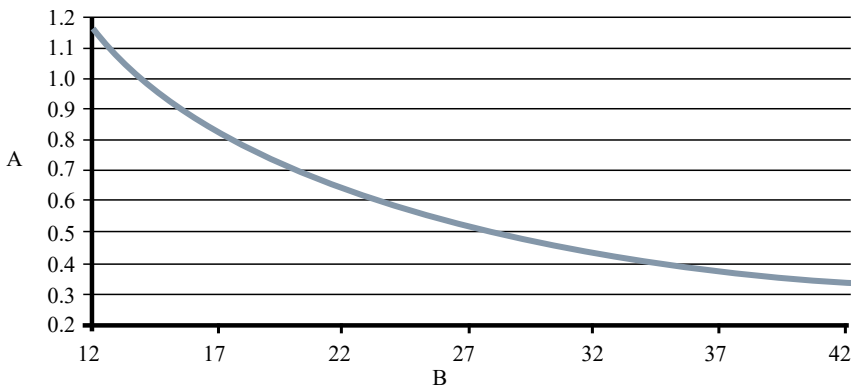

- A. Supply current (amps)
- B. Power supply (VDC)

DC low power supply requirements

Figure 10: Low power DC current requirements

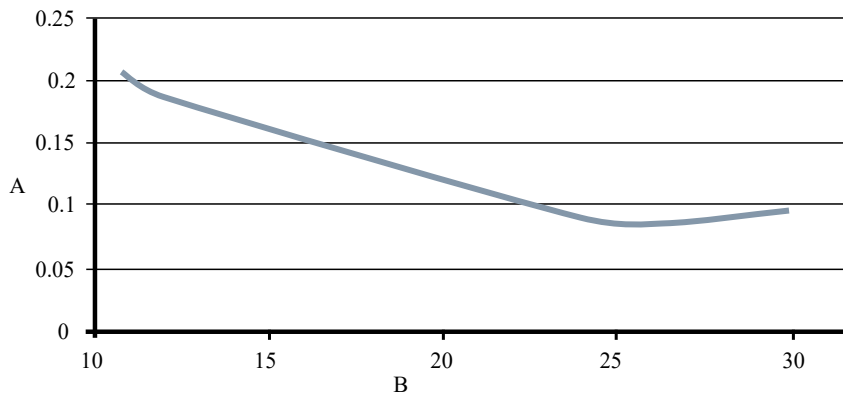

- A. Supply current (amps)
- B. Power supply (VDC)

Low power software option

This software option lowers the coil current from 500 mA to 75 mA in order to conserve power for applications in remote locations where power is scarce. The coils are still driven in a continuous manner optimizing measurement performance and providing access to all diagnostic capabilities. Because of the reduced coil current, flow measurement accuracy is reduced to 1% of rate for low power systems. [Table 27](#) shows the power consumption that can be expected for various configurations. Due to the reduced coil current, sensor size is limited to a maximum line size of 10-in. (250 mm).

The low power option is available for integral mount with DC power only (option code 3) and output code B (4-20 mA/HART/Pulse) or M (Modbus RS-485 / Pulse). To ensure the sensor will support the low power functionality, option code D3 for a low power calibration must appear in the sensor model number.

Sample model numbers for a low power system are:

8732EMT3M1N6M4DA1DA2

8705DHA020D7M0N6B3D3

Table 27: Low power consumption

Output code	Power consumption	Flow accuracy	Measurement range
Output Code B Utilize Pulse Output Only	2 Watts Maximum	1% of Rate	0.04 fps to 39 fps 0.01 m/s to 12 m/s
Output Code B Utilize Pulse and Analog Output	3 Watts Maximum	1% of Rate	0.04 fps to 39 fps 0.01 m/s to 12 m/s
Output code M Utilizing Modbus RS-485 and Pulse Output	4 Watts Maximum	1% of Rate	0.04 fps to 39 fps 0.01 m/s to 12 m/s

Ambient temperature limits

- Operating:
 - -58 to 140 °F (-50 to 60 °C) without LOI/Display
 - -4 to 140 °F (-20 to 60 °C) with LOI/Display
 - The LOI/Display will not be visible at temperatures below -4 °F (-20 °C)
- Storage:
 - -58 to 185 °F (-50 to 85 °C) without LOI/Display
 - -22 to 176 °F (-30 to 80 °C) with LOI/Display

Humidity limits

0-95% RH to 140 °F (60 °C)

Altitude limits

AC Input Voltage: Maximum 250 VAC – Up to 2000 meters (6,500 feet)

AC Input Voltage: Maximum 150 VAC – Up to 4000 meters (13,000 feet)

DC Input Voltage: No altitude limit

Transient protection rating

Built in transient protection that conforms to:

- IEC 61000-4-4 for burst currents
- IEC 61000-4-5 for surge currents
- IEC 611185-2.2000, Class 3 up to 2 kV and up to 2 kA protection

Turn-on time

- 5 minutes to rated accuracy from power up
- 5 seconds from power interruption

Start-up time

50ms from zero flow

Low flow cut-off

Adjustable between 0.01 and 38.37 ft/s (0.003 and 11.7 m/s). Below selected value, output is driven to the zero flow rate signal level.

Overrange capability

Signal output will remain linear until 110% of upper range value or 44 ft/s (13 m/s). The signal output will remain constant above these values. Out of range message displayed on LOI/Display and the Field Communicator.

Damping

Adjustable between 0 and 256 seconds

Advanced diagnostics capabilities**Basic**

- Self test
- Transmitter faults
- Analog output test
- Pulse output test

- Tunable empty pipe
- Reverse flow
- Ground/wiring fault
- Coil circuit fault
- Electronics temperature

Process diagnostics (DA1)

- High process noise
- Electrode coating diagnostic

Smart Meter Verification (DA2)

- Smart Meter Verification (continuous or commanded)
- 4-20 mA loop verification⁽²⁾

Output signals

Analog output adjustment ⁽³⁾

4–20 mA, switch-selectable as internally or externally powered.

Analog loop load limitations

- Internally powered 24 VDC max, 500 ohms max loop resistance
- Externally powered 10.8 - 30 VDC max.
- Loop resistance is determined by the voltage level of the external power supply at the transmitter terminals:

Figure 11: Analog loop load limitations

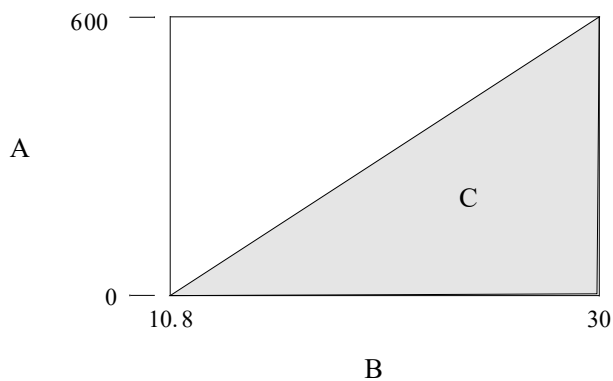

- A. Load (ohms)
- B. Power supply (volts)
- C. Operating region

- $R_{max} = 31.25 (V_{ps} - 10.8)$
- V_{ps} = power supply voltage (volts)
- R_{max} = maximum loop resistance (ohms)

(2) Available with HART output only.

(3) For transmitters with intrinsically safe outputs (option code B), power must be supplied externally.

The analog output is automatically scaled to provide 4 mA at lower range value and 20 mA at upper range value. Full scale continuously adjustable between -39 and 39 ft/s (-12 to 12 m/sec), 1 ft/s (0.3 m/s) minimum span.

HART Communications is a digital flow signal. The digital signal is superimposed on the 4–20 mA signal and is available for the control system interface. A minimum of 250 ohms loop resistance is required for HART communications.

Analog alarm mode

High or low alarm signal is user-selectable via the Alarm switch on the front of the electronics. NAMUR-compliant alarm limits are software configurable and can be preset via CDS (C1). Individual diagnostic alarms are also software configurable. Alarms will drive the analog signal to the following mA values.

Low	3.75 mA	Requires CDS (C1)
High	22.50 mA	Factory default
NAMUR Low	3.5 mA	Requires CDS (C1)
NAMUR High	22.6 mA	Requires CDS (C1)

FOUNDATION™ Fieldbus output

Output signal	Manchester-encoded digital signal that conforms to IEC 1158-2 and ISA 50.02
Scheduled Entries	Seven (7)
Links	Twenty (20)
Virtual Communications Relationships (VCRs)	One (1) predefined (F6, F7) Nineteen (19) configurable
FISCO compliant	Reference appropriate 8732EM Approvals QSG for details

FOUNDATION™ fieldbus function blocks

Table 28: Function block execution times

Block	Execution time (milliseconds)
Resource (RB)	—
Transducer (TB)	—
Analog Input (AI)	15
Proportional/Integral/Derivative (PID)	20
Integrator (INT)	25
Arithmetic (AR)	25
Discrete Output (DO)	15

Transducer Block	The transducer block calculates flow from the measured induced voltage. The calculation includes information related to the calibration number, line size, and diagnostics.
Resource Block	The resource block contains physical transmitter information, including available memory, manufacturer identification, device type, software tag, and unique identification.
Backup Link Active Scheduler (LAS)	The transmitter is classified as a device link master. A device link master can function as a Link Active Scheduler (LAS) if the current link master device fails or is removed from the segment. The host or other configuration tool is used to download the schedule for the application to the link master device. In the absence of a primary link master, the transmitter will claim the LAS and provide permanent control for the H1 segment.
Diagnostics	The transmitter automatically performs continuous self-diagnostics. The user can perform on-line testing of the transmitter digital signal. Advanced simulation diagnostics are available. This enables remote verification of the electronics via a flow signal generator built into the electronics.

	The sensor strength value can be used to view the process flow signal and provide information regarding filter settings.						
Analog Input	The AI function block processes the measurement and makes it available to other function blocks. The AI function block also allows filtering, alarming, and engineering unit changes.						
Arithmetic Block	Provides pre-defined application-based equations including flow with partial density compensation, electronic remote seals, hydrostatic tank gauging, ratio control and others.						
Proportional/Integral/Derivative	The PID function block provides a sophisticated implementation of the universal PID algorithm. The PID function block features input for feed forward control, alarms on the process variable, and control deviation. The PID type (series or Instrument Society of America [ISA]) is user-selectable on the derivative filter.						
Integrator	The standard integrator block is available for totalization of flow.						
	<table border="0"> <tr> <td>Reverse Flow</td> <td>Detects and reports reverse flow</td> </tr> <tr> <td>Software Lockout</td> <td>A write-lock switch and software lockout are provided in the resource function block.</td> </tr> <tr> <td>Totalizer</td> <td>Non-volatile totalizer for net, gross, forward and reverse totals.</td> </tr> </table>	Reverse Flow	Detects and reports reverse flow	Software Lockout	A write-lock switch and software lockout are provided in the resource function block.	Totalizer	Non-volatile totalizer for net, gross, forward and reverse totals.
Reverse Flow	Detects and reports reverse flow						
Software Lockout	A write-lock switch and software lockout are provided in the resource function block.						
Totalizer	Non-volatile totalizer for net, gross, forward and reverse totals.						
Discrete Output	The DO function block processes a discrete setpoint and saves it to a specified channel to produce an output signal. The block supports mode control, output tracking, and simulation.						

Modbus RS-485 output

Transmitters with a Modbus output provide an RS-485 signal to a Modbus host system; data rates can be configured from 1200 baud to 115.2 kilobaud.

Profibus PA output

See *Rosemount 8700 Series Magnetic Flowmeter Systems Product Data Sheet* (document number [00813-0100-4727](#)).

Scalable pulse frequency adjustment

- 0-10,000 Hz, switch-selectable as internally or externally powered ⁽⁴⁾
- Pulse value can be set to equal desired volume in selected engineering units
- Pulse width adjustable from 0.1 to 650 ms
- Internally powered: Outputs up to 12 VDC⁽⁵⁾
- Externally powered: Input 5 - 28 VDC

Output testing

Analog output test ⁽⁵⁾ Transmitter may be commanded to supply a specified current between 3.5 and 23 mA.

Pulse output test Transmitter may be commanded to supply a specified frequency between 1 and 10,000 Hz.⁽⁴⁾

⁽⁴⁾ For transmitters with intrinsically safe outputs (option code B), frequency range is limited to 0-5000 Hz and must be powered externally.

⁽⁵⁾ For transmitters with intrinsically safe outputs (option code B), power must be supplied externally.

Optional discrete output function (AX option)

Externally powered at 5 - 28 VDC, 240 mA max, solid state switch closure to indicate either:

Reverse flow	Activates switch closure output when reverse flow is detected.
Zero flow	Activates switch closure output when flow goes to 0 ft/s or below low flow cutoff.
Empty pipe	Activates switch closure output when an empty pipe condition is detected.
Transmitter faults	Activates switch closure output when a transmitter fault is detected.
Flow limit 1, flow limit 2	Activates switch closure output when the transmitter measures a flow rate that meets the conditions established for this alert. There are two independent flow limit alerts that can be configured as discrete outputs.
Totalizer limit	Activates switch closure output when the transmitter measures a total flow that meets the conditions established for this alert.
Diagnostic status	Activates switch closure output when the transmitter detects a condition that meets the configured criteria of this output.

Optional discrete input function (AX option)

Externally powered at 5 - 28 VDC, 1.4 - 20 mA to activate switch closure to indicate either:

Reset Totalizer A (or B or C)	Resets Totalizer A (or B or C) value to zero.
Reset All Totals	Resets all totalizer values to zero.
Positive Zero Return (PZR)	Forces outputs of the transmitter to zero flow.

Security lockout

Security lockout switch on the electronics board can be set to deactivate all LOI and HART-based communicator functions to protect configuration variables from unwanted or accidental change.

LOI lockout

The display can be manually locked to prevent unintentional configuration changes. The display lock can be activated through a HART communication device, or by holding the UP arrow for 3 seconds and then following the on-screen instructions. When the display lock is activated, a lock symbol will appear in the lower right hand corner of the display. To deactivate the display lock, hold the UP arrow for 3 seconds and follow the on-screen instructions.

Display auto lock can be configured from the LOI with the following settings: OFF, 1 Minute, or 10 Minutes.

Sensor compensation

Rosemount sensors are calibrated in a flow lab at the factory and are assigned a calibration number. The calibration number must be entered into the transmitter, enabling interchangeability of sensors without calculations or a compromise in standard accuracy.

Transmitters and other manufacturers' sensors can be calibrated at known process conditions or at the Rosemount NIST-Traceable Flow Facility. Transmitters calibrated on site require a two-step procedure to match a known flow rate. This procedure can be found in the operations manual.

Performance specifications

System specifications are given using the frequency output and with the unit at reference conditions.

Accuracy

Includes the combined effects of linearity, hysteresis, and repeatability.

Rosemount 8705-M Sensor

- Standard system accuracy:
 - $\pm 0.25\%$ of rate ± 1.0 mm/sec from 0.04 to 6 ft/s (0.01 to 2 m/s)
 - $\pm 0.25\%$ of rate ± 1.5 mm/sec above 6 ft/s (2 m/s)
- Optional high accuracy:⁽⁶⁾
 - $\pm 0.15\%$ of rate ± 1.0 mm/sec from 0.04 to 13 ft/s (0.01 to 4 m/s)
 - $\pm 0.18\%$ of rate above 13 ft/s (4 m/s)

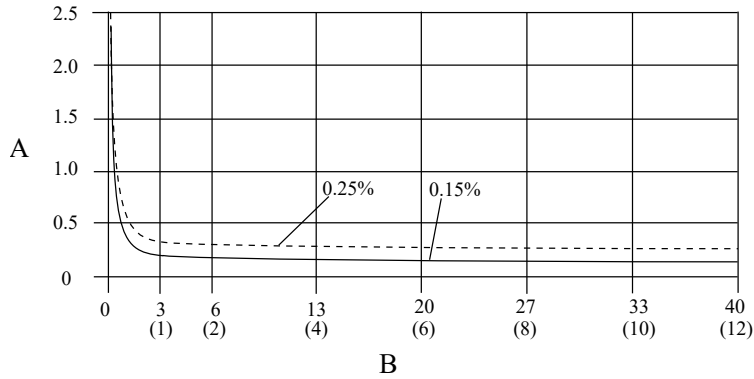

A. Percentage of rate
B. Velocity in ft/s (m/s)

Rosemount 8711-M/L Sensor

- Standard system accuracy:
 - $\pm 0.25\%$ of rate ± 2.0 mm/sec from 0.04 to 39 ft/s (0.01 to 12 m/s)
- Optional high accuracy:
 - $\pm 0.15\%$ of rate ± 1.0 mm/sec from 0.04 to 13 ft/s (0.01 to 4 m/s)
 - $\pm 0.18\%$ of rate above 13 ft/s (4 m/s)

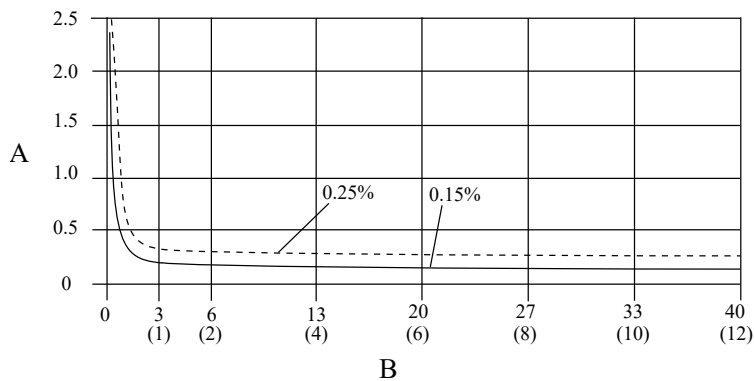

A. Percentage of rate
B. Velocity in ft/s (m/s)

(6) For sensor sizes greater than 12 in. (300 mm), the high accuracy is $\pm 0.25\%$ of rate from 3 to 39 ft/sec (1 to 12 m/sec).

Rosemount 8721 Sensor

- Standard system accuracy:
 - ± 1.5 mm/s from 0.04 to 1.0 ft/s (0.01 and 0.3 m/s)
 - $\pm 0.5\%$ of rate from 1 to 39 ft/s (0.3 to 12 m/s)
- Optional high accuracy:
 - $\pm 0.25\%$ of rate from 3 to 39 ft/s (1 to 12 m/s):

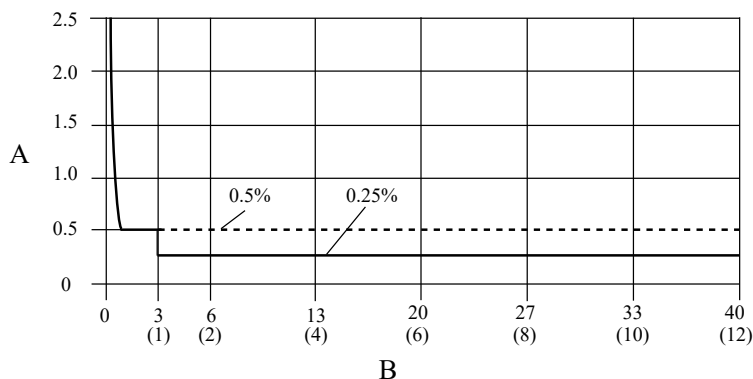

A. Percentage of rate
 B. Velocity in ft/s (m/s)

Other manufacturers' sensors

- When calibrated in the Rosemount Flow Facility, system accuracies as good as 0.5% of rate can be attained.
- There is no accuracy specification for other manufacturers' sensors calibrated in the process line.

Analog output effects

Analog output has the same accuracy as frequency output plus an additional $\pm 4 \mu A$ at room temperature.

Repeatability	$\pm 0.1\%$ of reading
Response time (analog output)	20 ms max response time to step change in input
Stability	$\pm 0.1\%$ of rate over six months
Ambient temperature effect	$\pm 0.25\%$ change over operating temperature range

8712 Wall mount transmitter physical specifications

Materials of construction

Housing	Low copper aluminum Type 4X and IEC 60529 IP66, IP69
Paint	Polyurethane coat (1.8 to 2.2 mils thick)
Cover gaskets	Silicone

Electrical connections

Conduit entries	$\frac{1}{2}$ -14 NPT or M20-1.5 ⁽¹⁾
Terminal block screws	6-32 (No. 6) suitable for up to 14 AWG wire
Safety grounding screws	External stainless assembly, M5; internal 8-32 (No. 8)

(1) M20-1.5 connections provided with an adapter.

Vibration rating

2G per IEC 61298

Dimensions

See [Figure 12](#).

Weight

Wall mount transmitter	Approximately 11 lbs. (5 kg)
------------------------	------------------------------

Add 1 pound (0.5 kg) for LOI/Display.

8732 Field mount transmitter physical specifications

Materials of construction

Standard housing	Low copper aluminum Type 4X and IEC 60529 IP66/67/68/69 ⁽¹⁾
Paint	Polyurethane coat (1.8 to 2.2 mils thick)
Optional housing	316/316L unpainted, option code SH Type 4X and IEC 60529 IP66/67/68/69 ⁽¹⁾
Cover gasket	Aluminum housing: Buna-N 316 SST housing: Silicone

⁽¹⁾ For applications where the transmitter may be submerged, even temporarily, contact Emerson Flow Technical Support for details.

Electrical connections

Conduit entries	Available in 1/2 inch NPT or M20. See ordering table footnotes for details.
Terminal block screws	6-32 (No. 6) suitable for up to 14 AWG wire
Safety grounding screws	External stainless assembly, M5; internal 8-32 (No. 8)

Vibration rating

Integral mount	2G per IEC 61298
Remote mount	5G per IEC 61298

Dimensions

See [Figure 13](#).

Weight

Field mount transmitter only	Aluminum	Approximately 7 lbs. (3.2 kg)
	316 stainless steel	Approximately 23 lbs. (10.5 kg)

Add 1 pound (0.5 kg) for LOI/Display.

8705-M Flanged Sensor Specifications



Functional specifications

Service

Conductive liquids and slurries

Line sizes

½ inch to 36 inch (15 mm to 900 mm)

Sensor coil resistance

2 - 20 Ω

Interchangeability

Rosemount 8705-M sensors are interchangeable with 8712EM and 8732EM transmitters. System accuracy is maintained regardless of line size or optional features. Each sensor nameplate has a sixteen-digit calibration number that can be entered into a transmitter during configuration.

Upper range limit

39.37 ft/s (12 m/s)

Ambient temperature limits

- -20 to 140 °F (-29 to 60 °C) standard carbon steel housing design
- -58 to 140 °F (-50 to 60 °C) with "SH" all stainless housing design⁽⁷⁾

Pressure limits

See [Process temperature limits](#).

Vacuum limits

PTFE lining	Full vacuum to +350 °F (+177 °C) through 4-in. (100 mm) line sizes. Consult an Emerson Flow representative for vacuum applications with line sizes of 6 inches (150 mm) or larger.
All other standard sensor lining materials	Full vacuum to maximum material temperature limits for all available line sizes.

Submergence protection IP68

The remote mount sensor is rated IP68 for continuous submergence. Tested to a depth of 33 ft (10 m) for a period of 48 hours. IP68 rating requires that the transmitter must be remote mount. Installer must use IP68 approved cable glands, conduit connections, and/or conduit plugs.

(7) Not available for Class/Div approval codes N5, N6, K5, KU.

Conductivity limits

Process liquid must have a conductivity of 5 microSiemens/cm or greater. Consult an Emerson Flow representative for conductivity less than 5 microSiemens/cm.

Process temperature limits

PTFE lining	-58 to +350 °F (-50 to +177 °C)
ETFE lining	-58 to +300 °F (-50 to +149 °C)
PFA and PFA+ lining	-58 to +350 °F (-50 to +177 °C)
Polyurethane lining	0 to +140 °F (-18 to +60 °C)
Neoprene lining	0 to +176 °F (-18 to +80 °C)
Linatex lining	0 to +158 °F (-18 to +70 °C)
Adiprene lining	0 to +200 °F (-18 to +93 °C)

Notes

- Carbon steel flanges for PED have a minimum process temperature limit of 32 °F (0 °C).
- Sensors ordered with hazardous location ratings may have different maximum process temperature limits. The sensors must be installed and used as directed by the installation drawing number noted on the serial nameplate.

Table 29: Temperature vs. Pressure Limits for ASME B16.5 class flanges ⁽¹⁾

Sensor temperature vs. pressure limits for ASME B16.5 class flanges (up to 36 inch Line Sizes) ⁽²⁾					
Flange material	Flange rating	Pressure			
		@ -20 to 100 °F (-29 to 38 °C)	@ 200 °F (93 °C)	@ 300 °F (149 °C)	@ 350 °F (177 °C)
Carbon Steel	Class 150	285 psi	260 psi	230 psi	215 psi
	Class 300	740 psi	680 psi	655 psi	645 psi
	Class 600 ⁽³⁾	1000 psi	800 psi	700 psi	650 psi
	Class 600 ⁽⁴⁾	1480 psi	1350 psi	1315 psi	1292 psi
	Class 900	2220 psi	2025 psi	1970 psi	1935 psi
	Class 1500	3705 psi	3375 psi	3280 psi	3225 psi
	Class 2500	6170 psi	5625 psi	5470 psi	5375 psi
304/304L Stainless Steel 316/316L Stainless Steel	Class 150	275 psi	235 psi	205 psi	190 psi
	Class 300	720 psi	620 psi	530 psi	500 psi
	Class 600 ⁽³⁾	1000 psi	800 psi	700 psi	650 psi
	Class 600 ⁽⁴⁾	1440 psi	1200 psi	1055 psi	997 psi
	Class 900	2160 psi	1800 psi	1585 psi	1497 psi
	Class 1500	3600 psi	3000 psi	2640 psi	2495 psi
	Class 2500	6000 psi	5000 psi	4400 psi	4160 psi

(1) Liner temperature limits must also be considered.
 (2) 30-in. and 36-in. AWWA C207 Class D rated to 150 psi at atmospheric temperature.
 (3) Flange rating Code 6.
 (4) Flange rating Code 7.

Table 30: Temperature vs. Pressure Limits for AS2129 Table D and E flanges ⁽¹⁾

Sensor temperature vs. pressure limits for AS2129 Table D and E flanges (4 inch to 24 inch line sizes)					
Flange Material	Flange Rating	Pressure			
		@ -29 to 50 °C (-20 to 122 °F)	@ 100 °C (212 °F)	@ 150 °C (302 °F)	@ 200 °C (392 °F)
Carbon Steel	D	101.6 psi	101.6 psi	101.6 psi	94.3 psi
	E	203.1 psi	203.1 psi	203.1 psi	188.6 psi

(1) Liner temperature limits must also be considered.

Table 31: Temperature vs. Pressure Limits for EN 1092-1 flanges ⁽¹⁾

Sensor temperature vs. pressure limits for EN 1092-1 flanges (15 mm to 600 mm Line Sizes)					
Flange material	Flange rating	Pressure			
		@ -29 to 50 °C (-20 to 122 °F)	@ 100 °C (212 °F)	@ 150 °C (302 °F)	@ 175 °C (347 °F)
Carbon Steel	PN 10	10 bar	10 bar	9.7 bar	9.5 bar
	PN 16	16 bar	16 bar	15.6 bar	15.3 bar
	PN 25	25 bar	25 bar	24.4 bar	24.0 bar
	PN 40	40 bar	40 bar	39.1 bar	38.5 bar
304/304L Stainless Steel 316/316L Stainless Steel	PN 10	9.1 bar	7.5 bar	6.8 bar	6.5 bar
	PN 16	14.7 bar	12.1 bar	11.0 bar	10.6 bar
	PN 25	23 bar	18.9 bar	17.2 bar	16.6 bar
	PN 40	36.8 bar	30.3 bar	27.5 bar	26.5 bar

(1) Liner temperature limits must also be considered.

Physical specifications

Emerson Rosemount magnetic flow meters are designed to the standards defined in ASME B31.3. This standard is used as the basis for all of our other pressure vessel certifications such as CRN and PED.

Non-wetted materials

Sensor Pipe	Type 304/304L SST or Type 316/316L SST
Flanges ⁽¹⁾	Flat-Face (FF) and Raised-Face (RF)
Coil housing	Rolled carbon steel or 300 series stainless steel
Remote junction box	Painted aluminum
Paint	Polyurethane coat (2.6 mils or greater)
Optional coil housing	316/316L unpainted, option code SH
Optional remote junction box	316/316L, unpainted, option code SJ; included with option code SH

(1) Ambient temperature low limit for A105 carbon steel is -20 °F (-29 °C) per ANSI B16.5. For colder ambient environments, stainless steel flanges must be used.

Process-wetted materials

Flanges ⁽¹⁾	Ring Type Joint (RTJ)
Lining	PTFE, ETFE, PFA, Polyurethane, Neoprene, Linatex, Adiprene, PFA+
Electrodes	316L SST, Nickel Alloy 276 (UNS N10276), Tantalum, 80% Platinum-20% Iridium, Titanium

(1) *Ambient temperature low limit for A105 carbon steel is -20 °F (-29 °C) per ANSI B16.5. For colder ambient environments, stainless steel flanges must be used.*

Flat-faced flanges

Sensors ordered with flat-faced flanges and Neoprene or Linatex liners are manufactured with the liner extending to the outer dimension of the flange. All other liner selections extend to the diameter of raised face dimension and create a raised surface on the flange face.

Process connections

ASME B16.5	<ul style="list-style-type: none"> ▪ Class 150 and Class 300: ½ inch to 24 inch (15 mm to 600 mm) ▪ Class 600: ½ inch to 24 inch (15 mm to 600 mm)⁽¹⁾ ▪ Class 900: 1 inch to 12 inch (25 mm to 300 mm)⁽²⁾ ▪ Class 1500: 1½ inch to 12 inch (40 mm to 300 mm)⁽²⁾ ▪ 1½ inch to 6 inch (40 mm to 150 mm)⁽²⁾
ASME B16.47	<ul style="list-style-type: none"> ▪ Class 150: 30 inch to 36 inch (750 mm to 900 mm) ▪ Class 300: 30 inch to 36 inch (750 mm to 900 mm)
AWWA C207	<ul style="list-style-type: none"> ▪ Class D: 30 inch and 36 inch (750 mm and 900 mm)
MSS SP44	<ul style="list-style-type: none"> ▪ Class 150: 30 inch to 36 inch (750 mm to 900 mm)
EN 1092-1	<ul style="list-style-type: none"> ▪ PN10: 200 mm to 900 mm (8 inch to 36 inch) ▪ PN16: 100 mm to 900 mm (4 inch to 36 inch) ▪ PN25: 200 mm to 900 mm (8 inch to 36 inch) ▪ PN40: 15 mm to 900 mm (½ inch to 36 inch)
AS2129	<ul style="list-style-type: none"> ▪ Table D and Table E: 15 mm to 900 mm (½ inch to 36 inch)
AS4087	<ul style="list-style-type: none"> ▪ PN16, PN21, PN35: 50 mm to 600 mm (2 inch to 24 inch)
JIS B2220	<ul style="list-style-type: none"> ▪ 10K, 20K, 40K: 15 mm to 200 mm (½ inch to 8 inch)

(1) *For PTFE, PFA, PFA+, and ETFE, maximum working pressure is derated to 1000 psig.*

(2) *For Class 900 and higher flange ratings, liner selection is limited to resilient liners.*

Electrical connections

Conduit entries	Available with ½ inch NPT and M20
Terminal block screws	6-32 (No. 6) suitable for up to 14 AWG wire
Safety grounding screws	External stainless assembly, M5; internal 8-32 (No. 8)

Process reference electrode (optional)

A process reference electrode can be installed similarly to the measurement electrodes through the sensor lining. It will be made of the same material as the measurement electrodes.

Grounding rings (optional)

Grounding rings can be installed between the flange and the sensor face on both ends of the sensor. Single ground rings can be installed on either end of the sensor. They have an I.D. slightly larger than the sensor I.D. and an external

tab to attach ground straps. Grounding rings are available in 316L SST, Nickel Alloy 276 (UNS N10276), titanium, and tantalum. See [Figure 23](#).

Lining protectors (optional)

Lining protectors can be installed between the flange and the sensor face on both ends of the sensor. The leading edge of lining material is protected by the lining protector; lining protectors cannot be removed once they are installed. Lining protectors are available in 316L SST, Nickel Alloy 276 (UNS N10276), and titanium. See [Figure 22](#).

Dimensions

See [Figure 13](#) through [Figure 21](#).

Weight

See [Table 34](#) through [Table 52](#).

8711-M/L Wafer Sensor Specifications



Functional specifications

Service

Conductive liquids and slurries

Line sizes

1.5-in. to 8-in. (40 mm to 200 mm)

Sensor coil resistance

10 - 18 Ω

Interchangeability

Rosemount 8711-M/L Sensors are interchangeable with 8712EM and 8732EM Transmitters. System accuracy is maintained regardless of line size or optional features. Each sensor nameplate has a sixteen-digit calibration number that can be entered into a transmitter during configuration.

Upper range limit

39.37 ft/s (12 m/s)

Process temperature limits

ETFE lining	-20 to 300 °F (-29 to 149 °C)
PTFE lining	-20 to 350 °F (-29 to 177 °C)

Ambient temperature limits

-20 to 140 °F (-29 to 60 °C)

Maximum safe working pressure at 100 °F (38 °C)

ETFE lining	Full vacuum to 740 psi (5.1 MPa)
PTFE lining	<ul style="list-style-type: none"> ■ Line sizes 1.5-in. (40 mm) through 4-in. (100 mm); Full vacuum to 740 psi (5.1 MPa) ■ Consult Technical Support for vacuum applications with line sizes of 6-in. (150 mm) or larger

Submergence protection IP68

The remote mount sensor is rated IP68 for continuous submergence. Tested to a depth of 33 ft (10 m) for a period of 48 hours. IP68 rating requires that the transmitter must be remote mount. Installer must use IP68 approved cable glands, conduit connections, and/or conduit plugs.

Conductivity limits

Process liquid must have a minimum conductivity of 5 microSiemens/cm (5 micromhos/cm) or greater for 8711.

Physical specifications**Non-wetted materials**

Sensor body	<ul style="list-style-type: none"> ■ 303 SST ■ CF3M or CF8M ■ Type 304/304L
Coil housing	Rolled carbon steel
Remote junction box	Painted aluminum
Paint	Polyurethane coat (2.6 mils or greater)

Process-wetted materials

Lining	PTFE, ETFE
Electrodes	316L SST, Nickel Alloy 276 (UNS N10276), Tantalum, 80% Platinum—20% Iridium, Titanium

Electrical connections

Conduit entries	Available with 1/2 inch NPT and M20. See ordering table footnotes for details
Terminal block screws	6-32 (No. 6) suitable for up to 14 AWG wire
Safety grounding screws	External stainless assembly, M5; internal 8-32 (No. 8)

Process reference electrode (optional)

A process reference electrode can be installed similarly to the measurement electrodes through the sensor lining. It will be made of the same material as the measurement electrodes.

Grounding rings (optional)

Grounding rings can be installed between the flange and the sensor face on both ends of the sensor. They have an I.D. slightly smaller than the sensor I.D. and an external tab to attach ground wiring. Grounding rings are available in 316L SST, Nickel Alloy 276 (UNS N10276), titanium, and tantalum. See [Table 24](#).

DimensionsSee [Figure 24](#).**Weight**See [Table 54](#).**Process connections—Mounts between these flange configurations**

ASME B16.5	Class 150, 300
EN 1092-1	PN10, PN16, PN25, PN40
JIS B2220	10K, 20K
AS4087	PN16, PN21, PN35

Studs, nuts, and washers—MK2-carbon steel

Component	ASME B16.5	EN1092-1
Studs, full thread	CS, ASTM A193, Grade B7	CS, ASTM A193, Grade B7
Hex nuts	ASTM A194 Grade 2H	ASTM A194 Grade 2H; DIN 934 H = D
Flat washers	CS, Type A, Series N, SAE per ANSI B18.2.1	CS, DIN 125
All items	Clear, chromate zinc-plated	Yellow zinc-plated

Studs, nuts, and washers—MK3-316 SST

Component	ASME B16.5	EN1092-1
Studs, full thread	ASTM A193, Grade B8M Class 1	ASTM A193, Grade B8M Class 1
Hex nuts	ASTM A194 Grade 8M	ASTM A194 Grade 8M; DIN 934 H = D
Flat washers	316 SST, Type A, Series N, SAE per ANSI B18.2.1	316 SST, DIN 125

8721 Hygienic (Sanitary) Sensor Specifications**Functional specifications****Service**

Conductive liquids and slurries

Line sizes

1/2 -in. to 4-in. (15 mm to 100 mm)

Sensor coil resistance

5 -10 Ω

Interchangeability

Rosemount 8721 sensors are interchangeable with Rosemount 8712EM and 8732EM transmitters. System accuracy is maintained regardless of line size or optional features. Each sensor label has a 16 digit calibration number that can be entered into the transmitter during configuration.

Conductivity limits

Process liquid must have a minimum conductivity of 5 microSiemens/cm (5 micromhos/cm) or greater. Excludes the effect of interconnecting cable length in remote mount transmitter installations.

Flow rate range

Capable of processing signals from fluids that are traveling between 0.04 and 39 ft/s (0.01 to 12 m/s) for both forward and reverse flow in all sensor sizes. Full scale continuously adjustable between -39 and 39 ft/s (-12 to 12 m/s).

Sensor ambient temperature limits

14 to 140 °F (-15 to 60 °C)

Process temperature limits

PFA lining -20 to 350 °F (-29 to 177 °C)

Table 32: Pressure limits

Line size	Max working pressure	CE mark max. working pressure
1/2 -in. (15 mm)	300 psi (20.7 bar)	300 psi (20.7 bar)
1-in. (25 mm)	300 psi (20.7 bar)	300 psi (20.7 bar)
1 1/2 -in. (40 mm)	300 psi (20.7 bar)	300 psi (20.7 bar)
2-in. (50 mm)	300 psi (20.7 bar)	300 psi (20.7 bar)
2 1/2 -in. (65 mm)	300 psi (20.7 bar)	240 psi (16.5 bar)
3 -in. (80 mm)	300 psi (20.7 bar)	198 psi (13.7 bar)
4-in. (100 mm)	210 psi (14.5 bar)	148 psi (10.2 bar)

Vacuum limits

Full vacuum at maximum lining material temperature; consult Technical Support.

Submergence protection IP68

The remote mount 8721 sensor is rated IP68 for submergence to a depth of 33 ft (10 m) for a period of 48 hours. IP68 rating requires that the transmitter must be remote mount. Installer must use IP68 approved cable glands, conduit connections, and/or conduit plugs.

Sanitary fitting torque

Hand tighten IDF nut to approximately 50 in-lbs [5 1/2 Newton-meters (N-m)] of torque. Re-tighten after a few minutes until there are no leaks (up to 130 in-lbs [14 1/2 Newton-meters (N-m)] of torque).

Fittings that continue to leak at a higher torque may be distorted or damaged.

Physical specifications

Mounting

Integrally mounted transmitters are factory-wired and do not require interconnecting cables. The transmitter can rotate in 90° increments. Remote-mounted transmitters require only a single conduit connection to the sensor.

Non-wetted materials

Sensor	304 Stainless Steel (wrapper), 304 Stainless Steel (pipe)
Terminal junction box	Low copper aluminum Optional: 304 Stainless Steel

Process wetted materials (sensor)

Liner	PFA with Ra < 32 μ in. (0.81 μ m)
Electrodes	<ul style="list-style-type: none"> ▪ 316L SST with Ra < 15μ in. (0.38 μm) ▪ Nickel Alloy 276 (UNS N10276) with Ra < 15μ in. (0.38 μm) ▪ 80% Platinum-20% Iridium with Ra < 15μ in. (0.38 μm)

Process connections

The Rosemount 8721 Sanitary Sensor is designed using a standard IDF fitting as the basis for providing a flexible, hygienic interface for a variety of process connections. The Rosemount 8721 Sensor has the threaded or “male” end of the IDF fitting on the ends of the base sensor. The sensor can be directly connected with user supplied IDF fittings and gaskets. If other process connections are needed, the IDF fittings and gaskets can be provided and welded directly into the sanitary process tubing, or can be supplied with adapters to standard Tri Clamp process connections. All connections are PED compliant for group 2 fluids.

Tri Clamp sanitary coupling	<ul style="list-style-type: none"> ▪ IDF Sanitary Coupling (screw type) ▪ IDF specification per BS4825 part 4 ▪ ANSI Weld Nipple ▪ DIN 11850 Weld Nipple ▪ DIN 11851 (Imperial and Metric) ▪ DIN 11864-1 form A ▪ DIN 11864-2 form A ▪ SMS 1145 ▪ Cherry-Burrell I-Line
-----------------------------	--

Process connection material

- 316L Stainless Steel with Ra < 32 μ in. (0.81 μ m)
- Optional Electropolished Surface Finish with Ra < 15 μ in. (0.38 μ m)

Process connection gasket material

- Silicone
- EPDM
- Viton

Electrical connections

Conduit entries	½ -in. NPT standard, M20 adapters
Terminal block screws	M3
Safety grounding screws	External stainless assembly, M5; internal 6-32 (No. 6)

Dimensions

See [Figure 26](#) through [Figure 33](#); [Table 55](#) and [Table 56](#).

Weight

Table 33: 8721 Sensor Weight

Line size	Sensor only	008721-0350 Tri Clamp fitting (Each)
1/2 -in. (15 mm)	4.84 lbs (2.20 kg)	0.58 lbs (0.263 kg)
1-in. (25 mm)	4.52 lbs (2.05 kg)	0.68 lbs (0.309 kg)
1 1/2 -in. (40 mm)	5.52 lbs (2.51 kg)	0.88 lbs (0.400 kg)
2-in. (50 mm)	6.78 lbs (3.08 kg)	1.30 lbs (0.591 kg)
2 1/2 -in. (65 mm)	8.79 lbs (4.00 kg)	1.66 lbs (0.727 kg)
3 -in. (80 mm)	13.26 lbs (6.03 kg)	2.22 lbs (1.01 kg)
4-in. (100 mm)	21.04 lbs (9.56 kg)	3.28 lbs (1.49 kg)

Aluminum remote junction box	<ul style="list-style-type: none"> ▪ Approximately 1 lb. (0.45 kg) ▪ Paint - Polyurethane (1.3 to 5 mils)
SST remote junction box	<ul style="list-style-type: none"> ▪ Approximately 2.5 lbs. (1.13 kg) ▪ Unpainted

8714D Reference Calibration Standard

Functional specifications

Ambient temperature limits

- Operating: - 30 to 140 °F (-34 to 60°C)
- Storage: -40 to 140°F (-40 to 60°C)

Humidity Limits

0 to 95% relative humidity

Performance specifications

Accuracy

- ±0.05% of rate at 30 ft/s
- ±0.10% of rate at 10 ft/s and 3 ft/s

Warm-up Time

30 minutes

Ambient Temperature Effect

< 0.015% of rate per 10°F (< 0.027% per 10°C)

Humidity Effect

- No effect from 0 to 60% relative humidity
- < 0.10% of rate from 60 to 90% relative humidity

Long-Term Stability

< 0.10% of rate shift in one year.

Physical specifications

Electrical connections

Electrical connections are compatible with Model 8712E or Model 8732E terminal blocks. Electrical connections are not compatible with Model 8712H terminal block.

Mounting

Any position is acceptable.

Materials of construction

Housing	Extruded aluminum
Covers	Stamped aluminum, silk-screened
Paint	Epoxy polyester

Weight

Approximately 10 lb (4.5 kg).

Product certifications

For detailed approval certification information and installation drawings, please see the appropriate document listed below:

- Document number 00825-MA00-0001: *Rosemount 8700M Approval Document - IECEx and ATEX*
- Document number 00825-MA00-0002: *Rosemount 8700M Approval Document - Class Division*
- Document number 00825-MA00-0003: *Rosemount 8700M Approval Document - North America Zone*
- Document number 00825-MA00-0007: *Rosemount 8700M Approval Document - NEPSI EN Zone 1 China*

NAMUR Compliance (8732E)

- NE21: Electromagnetic Compatibility of Equipment for Industrial Processes and Laboratory
- NE43: Standardisation of the Signal Level for the Failure Information of Digital Transmitters
- NE53: Software and Hardware of Field Devices and Signal Processing Devices with Digital Electronics
- NE70: Magnetic Inductive Flowmeters (MIF)
- NE95: Basic Principles of Homologation
- NE107: Self-Monitoring and Diagnosis of Field Devices

Dimensional drawings

8712 Wall mount transmitter dimensions

Figure 12: 8712 Wall mount transmitter dimensions

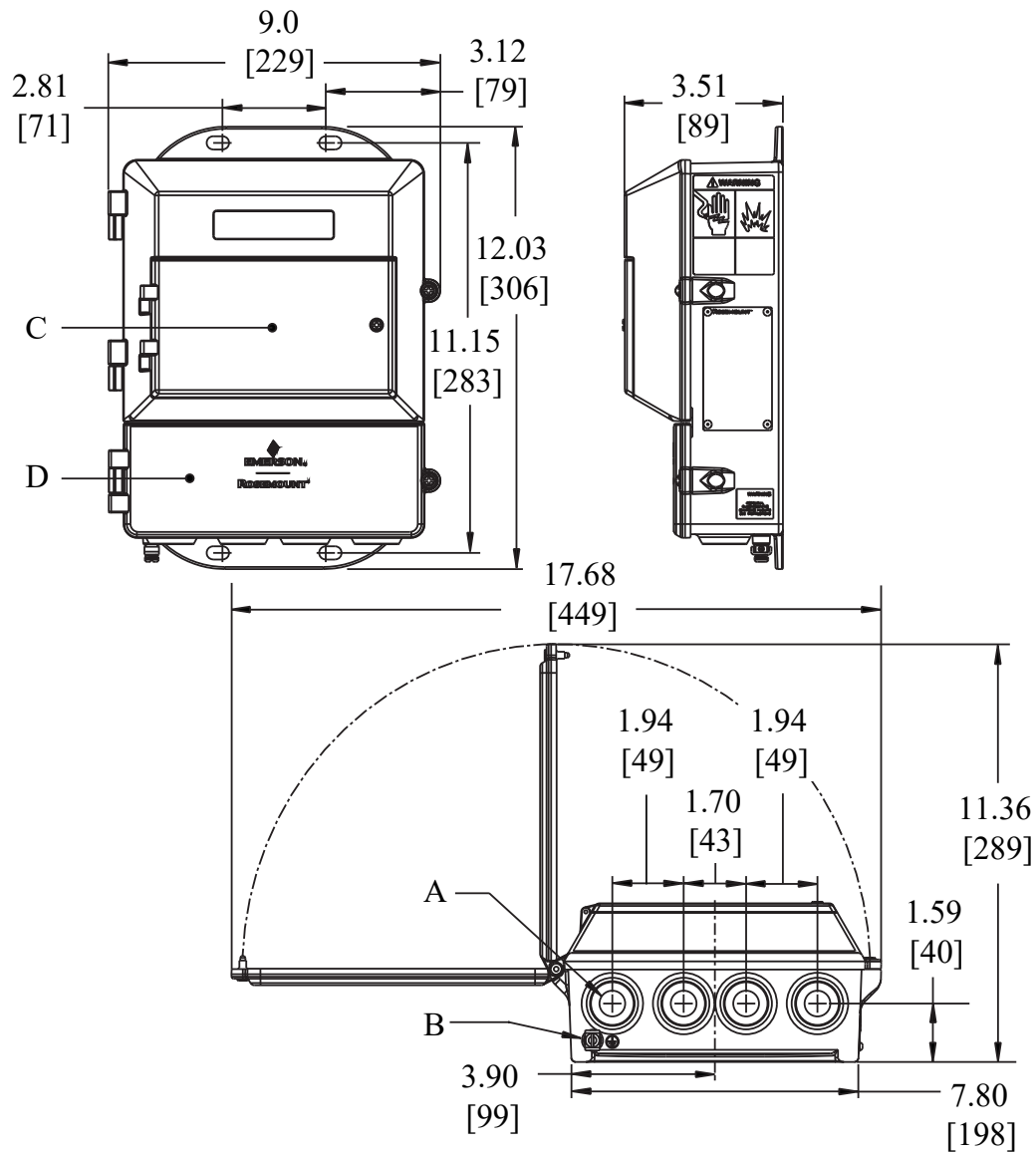

- A. Conduit entry, 1/2-14 NPT (4 places)
- B. Ground lug
- C. LOI keypad cover
- D. Lower cover opens for electrical connections

Note

Dimensions are in inches [millimeters].

8732 Field mount transmitter dimensions

Figure 13: 8732 Field mount transmitter dimensions

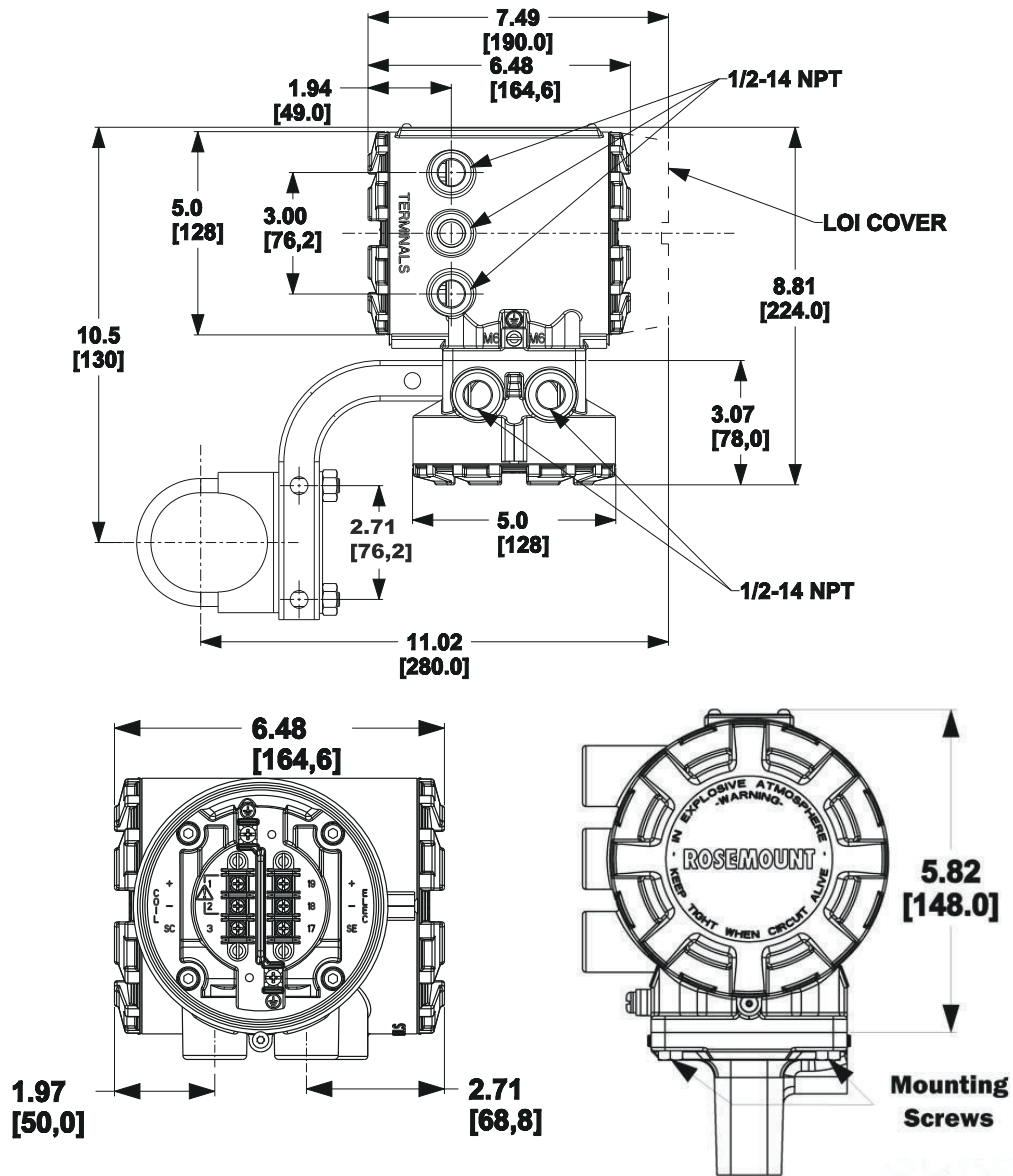

8705-M Low pressure sensor dimensions

The following notes apply to [Figure 14](#) through [Figure 16](#) and [Table 34](#) through [Table 45](#):

2.1 OPTIONAL RELIEF VALVE ASSEMBLY IS 1.75" [44,5].

3. DIM "A" FOR FLOWMETERS WITH SLIP-ON FLAT FACE (SO/FF) FLANGES IS EQUAL TO THAT OF A RAISED FACE FLANGE (SO/RF). IF USING LINING PROTECTORS, SEE "LINING PROTECTOR" SHEET. IF USING GROUND RINGS, SEE "GROUND RING" SHEET.

5. FOR BREVITY, THE MODEL NUMBER LIST ONLY CONTAINS THE CODES FOR CARBON STEEL FLANGES. 304 AND 316 STAINLESS STEEL FLANGES ARE DIMENSIONALLY IDENTICAL TO CARBON STEEL. USE THE TABLE BELOW TO FIND THE CARBON STEEL CODE THAT CORRESPONDS TO EACH STAINLESS STEEL CODE.

STAINLESS STEEL CODES	ARE THE SAME DIMENSIONS AS CARBON STEEL CODE
S,P	C
T,R	D
G,H	F
K,L	J

Figure 14: 8705-M Flanged sensor 0.5-in. to 2.5-in. (DN 15 mm to 65 mm) slip-on flanges—low pressure (P < Class 300)

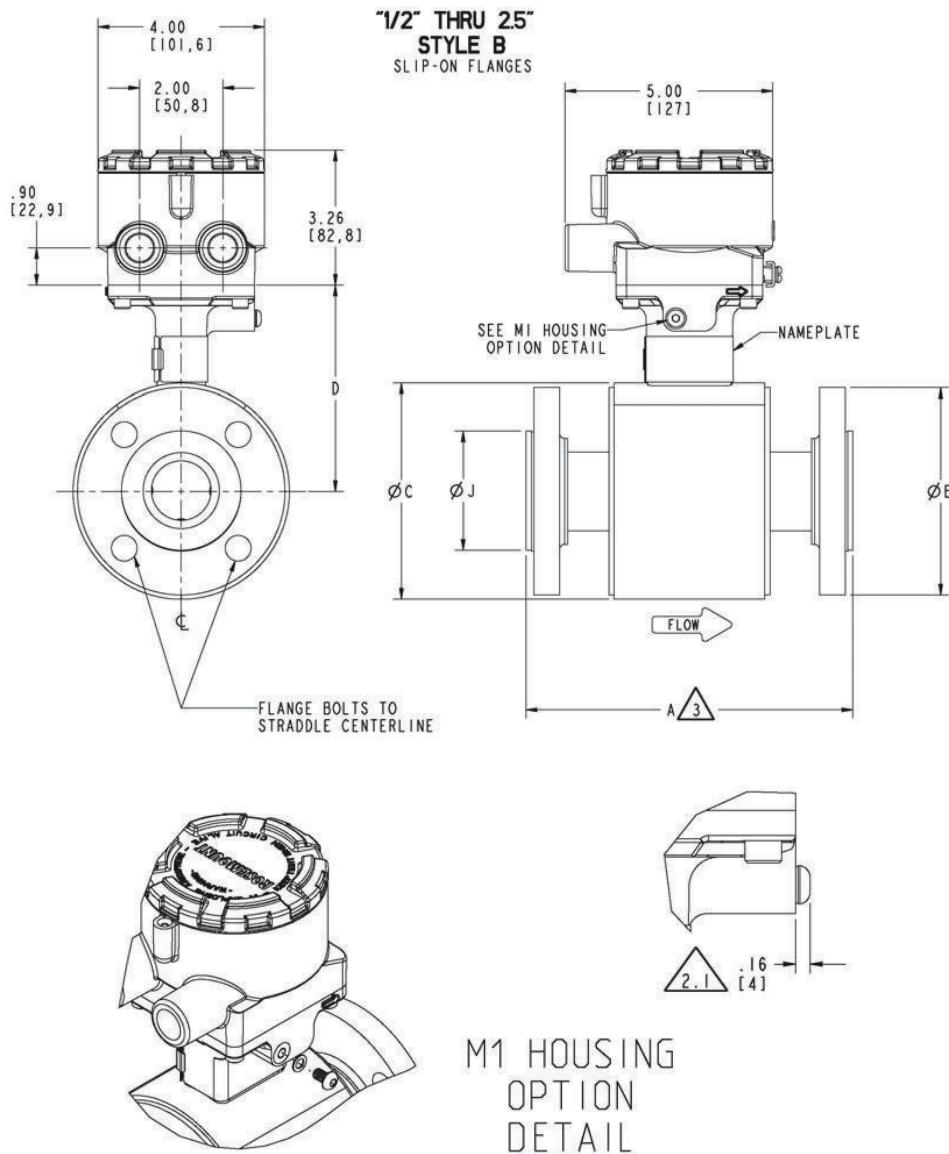

Table 34: 8705-M Flanged Sensor 0.5-in. to 2.5-in. slip-on flanges—low pressure (P ≤ Class 300)—Inches

SIZE, DESCRIPTION	MODEL NUMBER 	OVERALL LENGTH						FLANGE Ø DIM "B"	BODY Ø DIM "C"	DIM "D" CL to TA		LINER Ø ON FACE DIM "J"	FLOW TUBE WEIGHT (lbs.)
		DIM "A" PFE	DIM "A" ETFE	DIM "A" NEOPRENE	DIM "A" LINATEX	DIM "A" POLY	DIM "A" PFA			STYLE A	STYLE B		
0.5 (15) ASME - 150 , SO / RF	8705 _ _ _ 005C1	7.88	7.88	7.88	7.98	7.88	7.88	3.50	4.50	4.41	4.61	1.38	9
0.5 (15) ASME - 300 , SO / RF	8705 _ _ _ 005C3	7.88	7.88	7.88	7.98	7.88	7.88	3.75	4.50	4.41	4.61	1.38	10
0.5 (15) DIN - PN40, SO / RF	8705 _ _ _ 005CH	7.88	7.88	7.88	7.98	7.88	7.88	3.74	4.50	4.41	4.61	1.77	10
0.5 (15) AS2129 TABLE D, SO / RF	8705 _ _ _ 005CK	7.88	7.88	7.88	7.98	7.88		3.74	4.50	4.41	4.61	1.85	8
0.5 (15) AS2129 TABLE E, SO / RF	8705 _ _ _ 005CL	7.88		7.88	7.98	7.88		3.74	4.50	4.41	4.61	1.85	8
0.5 (15) JIS B2200 - 10K, SO / RF	8705 _ _ _ 005CP	7.88		7.88	7.98	7.88		3.74	4.50	4.41	4.61	1.77	10
0.5 (15) JIS B2200 - 20K, SO / RF	8705 _ _ _ 005CR	7.88		7.88	7.98	7.88		3.74	4.50	4.41	4.61	1.77	10
0.5 (15) JIS B2200 - 40K, SO / RF	8705 _ _ _ 005CT	8.38		8.38	8.48	8.38		4.53	4.50	4.41	4.61	1.77	13
1 (25) ASME - 150 , SO / RF	8705 _ _ _ 010C1	7.88	7.88	7.88	7.97	7.88	7.88	4.25	4.50	4.41	4.61	2.00	11
1 (25) ASME - 300 , SO / RF	8705 _ _ _ 010C3	7.88	7.88	7.88	7.97	7.88	7.88	4.88	4.50	4.41	4.61	2.00	14
1 (25) ASME - 600 DERAT., SO / RF	8705 _ _ _ 010C6	8.67	8.67	8.67	8.76	8.67		4.88	4.50	4.41	4.61	2.00	15
1 (25) DIN - PN40, SO / RF	8705 _ _ _ 010CH	7.88	7.88	7.88	7.97	7.88	7.88	4.53	4.50	4.41	4.61	2.68	14
1 (25) AS2129 TABLE D, SO / RF	8705 _ _ _ 010CK	7.88	7.88	7.88	7.97	7.88		4.53	4.50	4.41	4.61	2.56	10
1 (25) AS2129 TABLE E, SO / RF	8705 _ _ _ 010CL	7.88	7.88	7.88	7.97	7.88		4.53	4.50	4.41	4.61	2.48	10
1 (25) JIS B2200 - 10K, SO / RF	8705 _ _ _ 010CP	7.88		7.88	7.97	7.88		4.92	4.50	4.41	4.61	2.64	13
1 (25) JIS B2200 - 20K, SO / RF	8705 _ _ _ 010CR	7.88		7.88	7.97	7.88		4.92	4.50	4.41	4.61	2.64	14
1 (25) JIS B2200 - 40K, SO / RF	8705 _ _ _ 010CT	8.67		8.67	8.76	8.67		5.12	4.50	4.41	4.61	2.76	17
1.5 (40) ASME - 150 , SO / RF	8705 _ _ _ 015C1	7.87	7.87	7.80	7.90	7.87	7.87	5.00	5.21	4.82	4.97	2.88	15
1.5 (40) ASME - 300 , SO / RF	8705 _ _ _ 015C3	7.87	7.87	7.80	7.90	7.87	7.87	6.12	5.21	4.82	4.97	2.88	21
1.5 (40) ASME - 600 DERAT., SO / RF	8705 _ _ _ 015C6	8.63	8.63	8.56	8.65	8.63		6.12	5.21	4.82	4.97	2.88	23
1.5 (40) DIN - PN40, SO / RF	8705 _ _ _ 015CH	7.87	7.87	7.80	7.90	7.87	7.87	5.91	5.21	4.82	4.97	3.46	19
1.5 (40) AS2129 TABLE D, SO / RF	8705 _ _ _ 015CK	7.87		7.80	7.90	7.87		5.31	5.21	4.82	4.97	3.07	12
1.5 (40) AS2129 TABLE E, SO / RF	8705 _ _ _ 015CL	7.87		7.80	7.90	7.87		5.31	5.21	4.82	4.97	3.07	13
1.5 (40) JIS B2200 - 10K, SO / RF	8705 _ _ _ 015CP	7.87		7.80	7.90	7.87		5.51	5.21	4.82	4.97	3.19	16
1.5 (40) JIS B2200 - 20K, SO / RF	8705 _ _ _ 015CR	7.87		7.80	7.90	7.87		5.51	5.21	4.82	4.97	3.19	17
1.5 (40) JIS B2200 - 40K, SO / RF	8705 _ _ _ 015CT	8.63		8.56	8.65	8.63		6.30	5.21	4.82	4.97	3.54	24
2 (50) ASME - 150 , SO / RF	8705 _ _ _ 020C1	7.87	7.87	7.80	7.90	7.87	7.87	6.00	5.21	4.82	4.97	3.62	20
2 (50) ASME - 300 , SO / RF	8705 _ _ _ 020C3	7.87	7.87	7.80	7.90	7.87	7.87	6.50	5.21	4.82	4.97	3.62	23
2 (50) ASME - 600 DERAT., SO / RF	8705 _ _ _ 020C6	8.78	8.78	8.71	8.80	8.78		6.50	5.21	4.82	4.97	3.62	28
2 (50) DIN - PN40, SO / RF	8705 _ _ _ 020CH	7.87	7.87	7.80	7.90	7.87	7.87	6.50	5.21	4.82	4.97	4.02	23
2 (50) AS2129 TABLE D, SO / RF	8705 _ _ _ 020CK	7.87		7.80	7.90	7.87		5.91	5.21	4.82	4.97	3.54	14
2 (50) AS2129 TABLE E, SO / RF	8705 _ _ _ 020CL	7.87		7.80	7.90	7.87		5.91	5.21	4.82	4.97	3.54	15
2 (50) JIS B2200 - 10K, SO / RF	8705 _ _ _ 020CP	7.87		7.80	7.90	7.87		6.10	5.21	4.82	4.97	3.78	18
2 (50) JIS B2200 - 20K, SO / RF	8705 _ _ _ 020CR	7.87		7.80	7.90	7.87		6.10	5.21	4.82	4.97	3.78	19
2 (50) JIS B2200 - 40K, SO / RF	8705 _ _ _ 020CT	8.78		8.71	8.80	8.78		6.50	5.21	4.82	4.97	4.13	27
2 (50) AS4087 PN16, SO / RF	8705 _ _ _ 020CU	7.87		7.80	7.90	7.87		5.91	5.21	4.82	4.97	3.54	16
2 (50) AS4087 PN21, SO / RF	8705 _ _ _ 020CW	7.87		7.80	7.90	7.87		6.50	5.21	4.82	4.97	4.06	34
2 (50) AS4087 PN35, SO / RF	8705 _ _ _ 020CY	7.87		7.80	7.90	7.87		6.50	5.21	4.82	4.97	4.06	96
2.5 (65) ASME - 150 , SO / RF	8705 _ _ _ 025C1	7.82		7.76				7.00	6.31	5.37	5.52	4.12	27
2.5 (65) ASME - 300 , SO / RF	8705 _ _ _ 025C3	7.82		7.76				7.50	6.31	5.37	5.52	4.12	32
2.5 (65) ASME - 600 DERAT., SO / RF	8705 _ _ _ 025C6	8.86		8.80				7.50	6.31	5.37	5.52	4.12	40
2.5 (65) DIN - PN16, SO / RF	8705 _ _ _ 025CE	7.82		7.76				7.28	6.31	5.37	5.52	4.80	27
2.5 (65) DIN - PN40, SO / RF	8705 _ _ _ 025CH	7.82		7.76				7.28	6.31	5.37	5.52	4.80	31
2.5 (65) AS2129 TABLE D, SO / RF	8705 _ _ _ 025CK	7.82		7.76				6.50	6.31	5.37	5.52	4.06	17
2.5 (65) AS2129 TABLE E, SO / RF	8705 _ _ _ 025CL	7.82		7.76				6.50	6.31	5.37	5.52	4.06	19
2.5 (65) JIS B2200 - 10K, SO / RF	8705 _ _ _ 025CP	7.82		7.76				6.89	6.31	5.37	5.52	4.57	25
2.5 (65) JIS B2200 - 20K, SO / RF	8705 _ _ _ 025CR	7.82		7.76				6.89	6.31	5.37	5.52	4.57	26
2.5 (65) JIS B2200 - 40K, SO / RF	8705 _ _ _ 025CT	7.82		7.76				7.87	6.31	5.37	5.52	5.12	40
2.5 (65) AS4087 PN16, SO / RF	8705 _ _ _ 025CU	7.82		7.76				6.50	6.31	5.37	5.52	4.06	18
2.5 (65) AS4087 PN21, SO / RF	8705 _ _ _ 025CW	7.82		7.76				7.28	6.31	5.37	5.52	4.80	24
2.5 (65) AS4087 PN35, SO / RF	8705 _ _ _ 025CY	7.82		7.76				7.28	6.31	5.37	5.52	4.80	27

Table 35: 8705-M Flanged sensor DN 15mm to 65mm slip-on flanges—low pressure (P ≤ Class 300)—millimeters

SIZE, DESCRIPTION	MODEL NUMBER 	OVERALL LENGTH						FLANGE Ø DIM "B"	BODY Ø DIM "C"	DIM "D" CL to TA		LINER Ø ON FACE DIM "J"	FLOW TUBE WEIGHT (kg)
		DIM "A" PTFE	DIM "A" ETFE	DIM "A" NEOPRENE	DIM "A" LWATEX	DIM "A" POLY	DIM "A" PFA			STYLE A	STYLE B		
0.5 (15) ASME - 150 , SO / RF	8705 _ _ _ 005C1	200	200	200	203	200	200	89	114	112	117	35	4
0.5 (15) ASME - 300 , SO / RF	8705 _ _ _ 005C3	200	200	200	203	200	200	95	114	112	117	35	5
0.5 (15) DIN - PN40, SO / RF	8705 _ _ _ 005CH	200	200	200	203	200	200	95	114	112	117	45	5
0.5 (15) AS2129 TABLE D, SO / RF	8705 _ _ _ 005CK	200	200	200	203	200		95	114	112	117	47	4
0.5 (15) AS2129 TABLE E, SO / RF	8705 _ _ _ 005CL	200		200	203	200		95	114	112	117	47	4
0.5 (15) JIS B2200 - 10K, SO / RF	8705 _ _ _ 005CP	200		200	203	200		95	114	112	117	45	4
0.5 (15) JIS B2200 - 20K, SO / RF	8705 _ _ _ 005CR	200		200	203	200		95	114	112	117	45	5
0.5 (15) JIS B2200 - 40K, SO / RF	8705 _ _ _ 005CT	213		213	215	213		115	114	112	117	45	6
1 (25) ASME - 150 , SO / RF	8705 _ _ _ 010C1	200	200	200	202	200	200	108	114	112	117	51	5
1 (25) ASME - 300 , SO / RF	8705 _ _ _ 010C3	200	200	200	202	200	200	124	114	112	117	51	6
1 (25) ASME - 600 DERAT., SO / RF	8705 _ _ _ 010C6	220	220	220	223	220		124	114	112	117	51	7
1 (25) DIN - PN40, SO / RF	8705 _ _ _ 010CH	200	200	200	202	200	200	115	114	112	117	68	6
1 (25) AS2129 TABLE D, SO / RF	8705 _ _ _ 010CK	200	200	200	202	200		115	114	112	117	65	4
1 (25) AS2129 TABLE E, SO / RF	8705 _ _ _ 010CL	200	200	200	202	200		115	114	112	117	63	5
1 (25) JIS B2200 - 10K, SO / RF	8705 _ _ _ 010CP	200		200	202	200		125	114	112	117	67	6
1 (25) JIS B2200 - 20K, SO / RF	8705 _ _ _ 010CR	200		200	202	200		125	114	112	117	67	6
1 (25) JIS B2200 - 40K, SO / RF	8705 _ _ _ 010CT	220		220	223	220		130	114	112	117	70	8
1.5 (40) ASME - 150 , SO / RF	8705 _ _ _ 015C1	200	200	198	201	200	200	127	132	122	126	73	7
1.5 (40) ASME - 300 , SO / RF	8705 _ _ _ 015C3	200	200	198	201	200	200	155	132	122	126	73	9
1.5 (40) ASME - 600 DERAT., SO / RF	8705 _ _ _ 015C6	219	219	217	220	219		155	132	122	126	73	11
1.5 (40) DIN - PN40, SO / RF	8705 _ _ _ 015CH	200	200	198	201	200	200	150	132	122	126	88	9
1.5 (40) AS2129 TABLE D, SO / RF	8705 _ _ _ 015CK	200		198	201	200		135	132	122	126	78	6
1.5 (40) AS2129 TABLE E, SO / RF	8705 _ _ _ 015CL	200		198	201	200		135	132	122	126	78	6
1.5 (40) JIS B2200 - 10K, SO / RF	8705 _ _ _ 015CP	200		198	201	200		140	132	122	126	81	7
1.5 (40) JIS B2200 - 20K, SO / RF	8705 _ _ _ 015CR	200		198	201	200		140	132	122	126	81	8
1.5 (40) JIS B2200 - 40K, SO / RF	8705 _ _ _ 015CT	219		217	220	219		160	132	122	126	90	11
2 (50) ASME - 150 , SO / RF	8705 _ _ _ 020C1	200	200	198	201	200	200	152	132	122	126	92	9
2 (50) ASME - 300 , SO / RF	8705 _ _ _ 020C3	200	200	198	201	200	200	165	132	122	126	92	11
2 (50) ASME - 600 DERAT., SO / RF	8705 _ _ _ 020C6	223	223	221	224	223		165	132	122	126	92	13
2 (50) DIN - PN40, SO / RF	8705 _ _ _ 020CH	200	200	198	201	200	200	165	132	122	126	102	11
2 (50) AS2129 TABLE D, SO / RF	8705 _ _ _ 020CK	200		198	201	200		150	132	122	126	90	6
2 (50) AS2129 TABLE E, SO / RF	8705 _ _ _ 020CL	200		198	201	200		150	132	122	126	90	7
2 (50) JIS B220 - 10K, SO / RF	8705 _ _ _ 020CP	200		198	201	200		155	132	122	126	96	8
2 (50) JIS B220 - 20K, SO / RF	8705 _ _ _ 020CR	200		198	201	200		155	132	122	126	96	9
2 (50) JIS B220 - 40K, SO / RF	8705 _ _ _ 020CT	223		221	224	223		165	132	122	126	105	12
2 (50) AS4087 PN16, SO / RF	8705 _ _ _ 020CU	200		198	201	200		150	132	122	126	90	7
2 (50) AS4087 PN21, SO / RF	8705 _ _ _ 020CW	200		198	201	200		165	132	122	126	103	16
2 (50) AS4087 PN35, SO / RF	8705 _ _ _ 020CY	200		198	201	200		165	132	122	126	103	44
2.5 (65) ASME - 150 , SO / RF	8705 _ _ _ 025C1	199		197				178	160	136	140	105	12
2.5 (65) ASME - 300 , SO / RF	8705 _ _ _ 025C3	199		197				191	160	136	140	105	15
2.5 (65) ASME - 600 DERAT., SO / RF	8705 _ _ _ 025C6	225		224				191	160	136	140	105	18
2.5 (65) DIN - PN16, SO / RF	8705 _ _ _ 025CE	199		197				185	160	136	140	122	12
2.5 (65) DIN - PN40, SO / RF	8705 _ _ _ 025CH	199		197				185	160	136	140	122	14
2.5 (65) AS2129 TABLE D, SO / RF	8705 _ _ _ 025CK	199		197				165	160	136	140	103	8
2.5 (65) AS2129 TABLE E, SO / RF	8705 _ _ _ 025CL	199		197				165	160	136	140	103	8
2.5 (65) JIS B2200 - 10K, SO / RF	8705 _ _ _ 025CP	199		197				175	160	136	140	116	11
2.5 (65) JIS B2200 - 20K, SO / RF	8705 _ _ _ 025CR	199		197				175	160	136	140	116	12
2.5 (65) JIS B2200 - 40K, SO / RF	8705 _ _ _ 025CT	199		197				200	160	136	140	130	18
2.5 (65) AS4087 PN16, SO / RF	8705 _ _ _ 025CU	199		197				165	160	136	140	103	8
2.5 (65) AS4087 PN21, SO / RF	8705 _ _ _ 025CW	199		197				185	160	136	140	122	11
2.5 (65) AS4087 PN35, SO / RF	8705 _ _ _ 025CY	199		197				185	160	136	140	122	12

Figure 15: 8705-M Flanged Sensor 3-in. to 36-in. (DN 80mm to 900mm) slip-on flanges—low pressure (P ≤ Class 300)

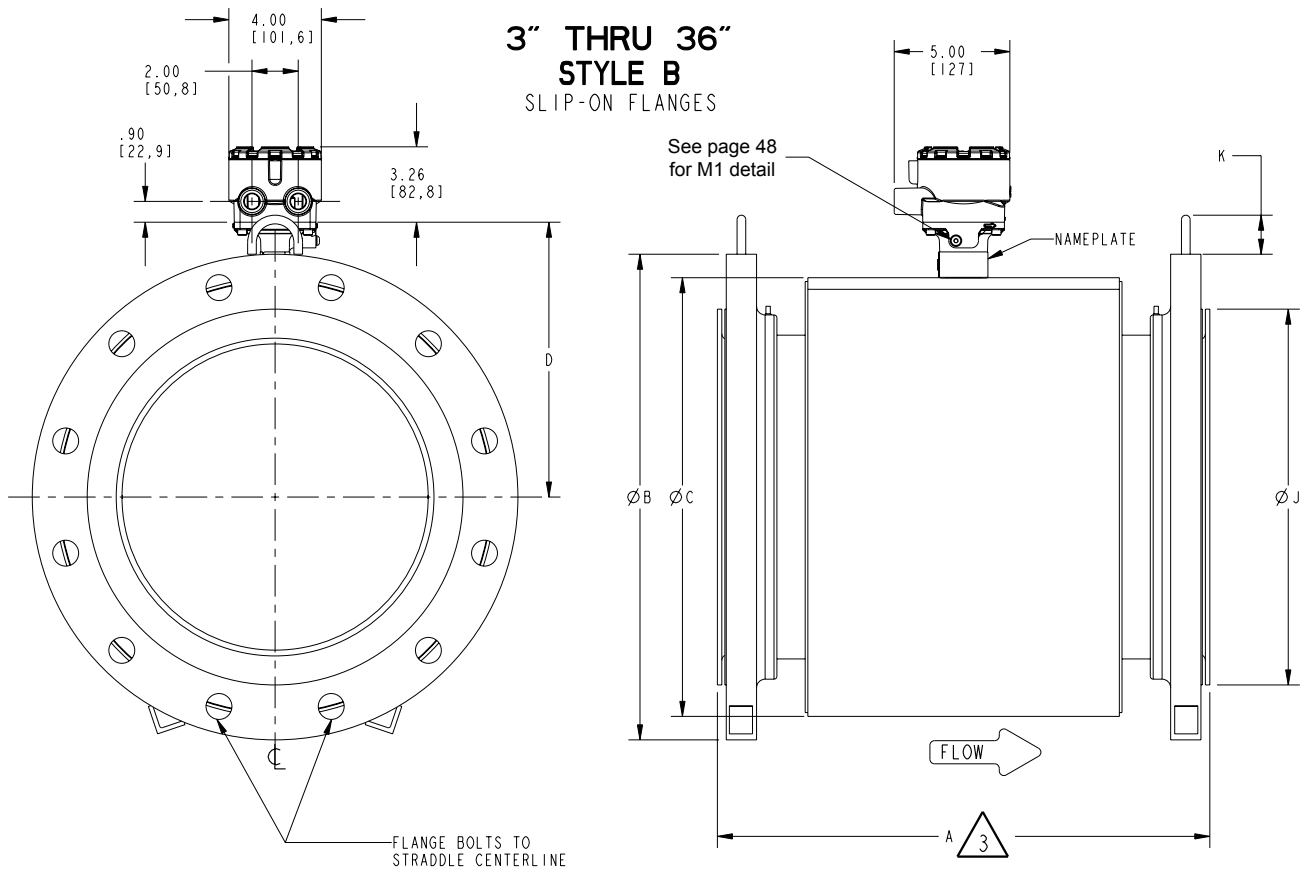

Table 36: 8705-M Flanged Sensor 3-in. to 6-in. slip-on flanges—low pressure (P ≤ Class 300)—Inches

SIZE, DESCRIPTION	MODEL NUMBER 	OVERALL LENGTH						FLANGE Ø DIM "B"	BODY Ø DIM "C"	DIM "D" CL to TA		LINER Ø ON FACE DIM "J"	LIFT RING HEIGHT DIM "K"	FLOW TUBE WEIGHT (lbs.)
		DIM "A" PTFE	DIM "A" ETFE	DIM "A" NEOPRENE	DIM "A" LINATEX	DIM "A" POLY	DIM "A" PFA			STYLE A	STYLE B			
3 (80) ASME - 150 , SO / RF	8705 _ _ _ 030C1	7.87	7.87	7.75	7.84	7.87	7.83	7.50	7.21	5.82	5.97	5.00	1.70	34
3 (80) ASME - 300 , SO / RF	8705 _ _ _ 030C3	8.63	8.63	8.51	8.60	8.63	8.60	8.25	7.21	5.82	5.97	5.00	1.70	43
3 (80) ASME - 600 DERAT., SO / RF	8705 _ _ _ 030C6	12.40	12.40	12.29	12.39	12.40		8.25	7.21	5.82	5.97	5.00	1.70	53
3 (80) EN1092-1- PN40, SO / RF	8705 _ _ _ 030CH	7.87	7.87	7.75	7.84	7.87	7.87	7.87	7.21	5.82	5.97	5.43	1.70	38
3 (80) AS2129 TABLE D, SO / RF	8705 _ _ _ 030CK	7.87		7.75	7.84	7.87		7.28	7.21	5.82	5.97	4.80	1.70	24
3 (80) AS2129 TABLE E, SO / RF	8705 _ _ _ 030CL	7.87		7.75	7.84	7.87		7.28	7.21	5.82	5.97	4.80	1.70	24
3 (80) JIS B2200 - 10K, SO / RF	8705 _ _ _ 030CP	7.87		7.75	7.84	7.87		7.28	7.21	5.82	5.97	4.96	1.70	28
3 (80) JIS B2200 - 20K, SO / RF	8705 _ _ _ 030CR	7.87		7.75	7.84	7.87		7.87	7.21	5.82	5.97	5.20	1.70	34
3 (80) JIS B2200 - 40K, SO / RF	8705 _ _ _ 030CT	12.40		12.29	12.39	12.40		8.27	7.21	5.82	5.97	5.51	1.70	52
3 (80) AS4087 PN16, SO / RF	8705 _ _ _ 030CU	7.87		7.75	7.84	7.87		7.28	7.21	5.82	5.97	4.80	1.70	20
3 (80) AS4087 PN21, SO / RF	8705 _ _ _ 030CW	7.87		7.75	7.84	7.87		8.07	7.21	5.82	5.97	5.55	1.70	56
3 (80) AS4087 PN35, SO / RF	8705 _ _ _ 030CY	7.87		7.75	7.84	7.87		8.07	7.21	5.82	5.97	5.55	1.70	109
4 (100) ASME - 150 , SO / RF	8705 _ _ _ 040C1	9.84	9.84	9.69	9.78	9.84	9.84	9.00	7.91	6.17	6.32	6.19	1.70	45
4 (100) ASME - 300 , SO / RF	8705 _ _ _ 040C3	10.88	10.88	10.73	10.82	10.88	10.88	10.00	7.91	6.17	6.32	6.19	1.70	65
4 (100) ASME - 600 DERAT., SO / RF	8705 _ _ _ 040C6	12.83	12.83	12.70	12.79	12.83		10.75	7.91	6.17	6.32	6.19	1.70	94
4 (100) EN1092-1 - PN16, SO / RF	8705 _ _ _ 040CE	9.84	9.81	9.69	9.78	9.81	9.81	8.66	7.91	6.17	6.32	6.22	1.70	41
4 (100) EN1092-1 - PN40, SO / RF	8705 _ _ _ 040CH	9.84	9.81	9.69	9.78	9.81	9.81	9.25	7.91	6.17	6.32	6.38	1.70	49
4 (100) AS2129 TABLE D, SO / RF	8705 _ _ _ 040CK	9.84	9.84	9.69	9.78	9.84		8.46	7.91	6.17	6.32	6.06	1.70	31
4 (100) AS2129 TABLE E, SO / RF	8705 _ _ _ 040CL	9.84	9.84	9.69	9.78	9.84		8.46	7.91	6.17	6.32	6.06	1.70	33
4 (100) JIS B2200 - 10K, SO / RF	8705 _ _ _ 040CP	9.84		9.69	9.78	9.84		8.27	7.91	6.17	6.32	5.95	1.70	35
4 (100) JIS B2200 - 20K, SO / RF	8705 _ _ _ 040CR	9.84		9.69	9.78	9.84		8.86	7.91	6.17	6.32	6.30	1.70	44
4 (100) JIS B2200 - 40K, SO / RF	8705 _ _ _ 040CT	12.83		12.70	12.79	12.83		9.84	7.91	6.17	6.32	6.50	1.70	75
4 (100) AS4087 PN16, SO / RF	8705 _ _ _ 040CU	9.84		9.69	9.78	9.84		8.46	7.91	6.17	6.32	6.06	1.70	28
4 (100) AS4087 PN21, SO / RF	8705 _ _ _ 040CW	9.84		9.69	9.78	9.84		9.06	7.91	6.17	6.32	6.57	1.70	68
4 (100) AS4087 PN35, SO / RF	8705 _ _ _ 040CY	9.84		9.69	9.78	9.84		9.06	7.91	6.17	6.32	6.57	1.70	119
5 (125) ASME - 150 , SO / RF	8705 _ _ _ 050C1	9.79		9.71				10.00	9.61	7.02	7.17	7.31	1.70	54
5 (125) ASME - 300 , SO / RF	8705 _ _ _ 050C3	10.94		10.86				11.00	9.61	7.02	7.17	7.31	1.70	89
5 (125) ASME - 600 DERAT., SO / RF	8705 _ _ _ 050C6	12.89		12.81				13.00	9.61	7.02	7.17	7.31	1.70	157
5 (125) EN1092-1 - PN16, SO / RF	8705 _ _ _ 050CE	9.79		9.50				9.84	9.61	7.02	7.17	7.40	1.70	55
5 (125) EN1092-1 - PN40, SO / RF	8705 _ _ _ 050CH	9.79		9.71				10.63	9.61	7.02	7.17	7.40	1.70	65
5 (125) AS2129 TABLE D, SO / RF	8705 _ _ _ 050CK	9.79		9.71				10.04	9.61	7.02	7.17	7.32	1.70	43
5 (125) AS2129 TABLE E, SO / RF	8705 _ _ _ 050CL	9.79		9.71				10.04	9.61	7.02	7.17	7.32	1.70	44
5 (125) JIS B2200 - 10K, SO / RF	8705 _ _ _ 050CP	9.79		9.71				9.84	9.61	7.02	7.17	7.17	1.70	49
5 (125) JIS B2200 - 20K, SO / RF	8705 _ _ _ 050CR	9.79		9.71				10.63	9.61	7.02	7.17	7.68	1.70	64
5 (125) JIS B2200 - 40K, SO / RF	8705 _ _ _ 050CT	10.94		10.86				11.81	9.61	7.02	7.17	7.87	1.70	112
6 (150) ASME - 150 , SO / RF	8705 _ _ _ 060C1	11.81	11.75	11.61	11.71	11.73	11.81	11.00	9.98	7.30	7.35	8.50	1.70	68
6 (150) ASME - 300 , SO / RF	8705 _ _ _ 060C3	13.06	13.02	12.88	12.97	13.00	13.06	12.50	9.98	7.30	7.35	8.50	1.70	117
6 (150) ASME - 600 DERAT., SO / RF	8705 _ _ _ 060C6	14.23	14.19	14.05	14.14	14.17		14.00	9.98	7.30	7.35	8.50	1.70	178
6 (150) EN1092-1 - PN16, SO / RF	8705 _ _ _ 060CE	11.81	11.75	11.61	11.71	11.73	11.81	11.22	9.98	7.30	7.35	8.35	1.70	67
6 (150) EN1092-1 - PN25, SO / RF	8705 _ _ _ 060CF	11.81	11.80	11.66	11.75	11.78	11.86	11.81	9.98	7.30	7.35	8.58	1.70	83
6 (150) EN1092-1 - PN40, SO / RF	8705 _ _ _ 060CH	13.06	13.02	12.88	12.97	13.00	13.06	11.81	9.98	7.30	7.35	8.58	1.70	95
6 (150) AS2129 TABLE D, SO / RF	8705 _ _ _ 060CK	11.81		11.61	11.71	11.73		11.02	9.98	7.30	7.35	8.31	1.70	52
6 (150) AS2129 TABLE E, SO / RF	8705 _ _ _ 060CL	11.81		11.61	11.71	11.73		11.02	9.98	7.30	7.35	8.15	1.70	57
6 (150) JIS B2200 - 10K, SO / RF	8705 _ _ _ 060CP	11.81		11.61	11.71	11.73		11.02	9.98	7.30	7.35	8.35	1.70	64
6 (150) JIS B2200 - 20K, SO / RF	8705 _ _ _ 060CR	11.81		11.61	11.71	11.73		12.01	9.98	7.30	7.35	9.06	1.70	82
6 (150) JIS B2200 - 40K, SO / RF	8705 _ _ _ 060CT	14.23		14.05	14.14	14.17		13.98	9.98	7.30	7.35	9.45	1.70	161
6 (150) AS4087 PN16, SO / RF	8705 _ _ _ 060CU	11.81		11.61	11.71	11.73		11.02	9.98	7.30	7.35	8.31	1.70	46
6 (150) AS4087 PN21, SO / RF	8705 _ _ _ 060CW	11.81		11.61	11.71	11.73		12.01	9.98	7.30	7.35	9.13	1.70	98
6 (150) AS4087 PN35, SO / RF	8705 _ _ _ 060CY	11.81		11.61	11.71	11.73		12.01	9.98	7.30	7.35	9.13	1.70	186

Table 37: 8705-M Flanged Sensor 8-in. to 12-in. slip-on flanges—low pressure (P ≤ Class 300)—Inches

SIZE, DESCRIPTION	MODEL NUMBER 	OVERALL LENGTH						FLANGE Ø DIM "B"	BODY Ø DIM "C"	DIM "D" CL to TA		LINER Ø ON FACE DIM "J"	LIFT RING HEIGHT DIM "K"	FLOW TUBE WEIGHT (lbs.)
		DIM "A" PTFE	DIM "A" ETFE	DIM "A" NEOPRENE	DIM "A" LINATEX	DIM "A" POLY	DIM "A" PFA			STYLE A	STYLE B			
8 (200) ASME - 150 , SO / RF	8705 _ _ _ 080C1	13.78	13.69	13.53	13.63	13.65	13.78	13.50	11.92	8.27	8.32	10.62	1.70	105
8 (200) ASME - 300 , SO / RF	8705 _ _ _ 080C3	15.60	15.54	15.42	15.51	15.54	15.60	15.00	11.92	8.27	8.32	10.62	1.70	183
8 (200) ASME - 600 DERAT. , SO / RF	8705 _ _ _ 080C6	16.72	16.66	16.54	16.63	16.66		16.50	11.92	8.27	8.32	10.62	1.70	272
8 (200) DIN - PN10, SO / RF	8705 _ _ _ 080CD	13.78	13.69	13.53	13.63	13.65	13.78	13.39	11.92	8.27	8.32	10.55	1.70	97
8 (200) DIN - PN16, SO / RF	8705 _ _ _ 080CE	13.78	13.69	13.53	13.63	13.65	13.78	13.39	11.92	8.27	8.32	10.55	1.70	96
8 (200) DIN - PN25, SO / RF	8705 _ _ _ 080CF	13.78	13.69	13.53	13.63	13.65	13.78	14.17	11.92	8.27	8.32	10.94	1.70	120
8 (200) DIN - PN40, SO / RF	8705 _ _ _ 080CH	15.60		15.54	15.51	15.54	15.60	14.76	11.92	8.27	8.32	11.22	1.70	158
8 (200) AS2129 TABLE D, SO / RF	8705 _ _ _ 080CK	13.78		13.53	13.63	13.65		13.19	11.92	8.27	8.32	10.55	1.70	77
8 (200) AS2129 TABLE E, SO / RF	8705 _ _ _ 080CL	13.78		13.53	13.63	13.65		13.19	11.92	8.27	8.32	10.39	1.70	86
8 (200) JIS B2200 - 10K, SO / RF	8705 _ _ _ 080CP	13.90		13.53	13.63	13.65		12.99	11.92	8.27	8.32	10.32	1.70	81
8 (200) JIS B2200 - 20K, SO / RF	8705 _ _ _ 080CR	15.60		15.42	15.51	15.54		13.78	11.92	8.27	8.32	10.83	1.70	134
8 (200) JIS B2200 - 40K, SO / RF	8705 _ _ _ 080CT	16.72		16.54	16.63	16.66		15.94	11.92	8.27	8.32	11.42	1.70	232
8 (200) AS4087 PN16, SO / RF	8705 _ _ _ 080CU	13.78		13.53	13.63	13.65		13.19	11.92	8.27	8.32	10.55	1.70	73
8 (200) AS4087 PN21, SO / RF	8705 _ _ _ 080CW	13.78		13.53	13.63	13.65		14.57	11.92	8.27	8.32	11.65	1.70	136
8 (200) AS4087 PN35, SO / RF	8705 _ _ _ 080CY	15.60		15.42	15.51	15.54		14.57	11.92	8.27	8.32	10.24	1.70	241
10 (250) ASME - 150 , SO / RF	8705 _ _ _ 100C1	15.00	14.85	14.63	14.73	14.75	15.00	16.00	14.64	9.69	9.68	12.75	2.00	152
10 (250) ASME - 300 , SO / RF	8705 _ _ _ 100C3	17.13	17.08	16.86	16.95	16.98	17.13	17.50	14.64	9.69	9.68	12.75	2.00	267
10 (250) ASME - 600 DERAT. , SO / RF	8705 _ _ _ 100C6	19.54	19.56	19.34	19.43	19.46		20.00	14.64	9.69	9.68	12.75	2.00	462
10 (250) DIN - PN10, SO / RF	8705 _ _ _ 100CD	15.00	14.85	14.63	14.73	14.75	15.00	15.55	14.64	9.69	9.68	12.60	2.00	134
10 (250) DIN - PN16, SO / RF	8705 _ _ _ 100CE	15.00	14.85	14.63	14.73	14.75	15.00	15.94	14.64	9.69	9.68	12.60	2.00	138
10 (250) DIN - PN25, SO / RF	8705 _ _ _ 100CF	15.00	14.85	14.63	14.73	14.75	15.00	16.73	14.64	9.69	9.68	13.19	2.00	174
10 (250) DIN - PN40, SO / RF	8705 _ _ _ 100CH	17.13		16.86	16.95	16.98	17.13	17.72	14.64	9.69	9.68	13.58	2.00	244
10 (250) AS2129 TABLE D, SO / RF	8705 _ _ _ 100CK	15.00		14.63	14.73	14.75		15.94	14.64	9.69	9.68	12.91	2.00	122
10 (250) AS2129 TABLE E, SO / RF	8705 _ _ _ 100CL	15.00		14.63	14.73	14.75		15.94	14.64	9.69	9.68	12.91	2.00	137
10 (250) JIS B2200 - 10K, SO / RF	8705 _ _ _ 100CP	15.00		14.63	14.73	14.75		15.75	14.64	9.69	9.68	12.76	1.70	129
10 (250) JIS B2200 - 20K, SO / RF	8705 _ _ _ 100CR	17.13		16.86	16.95	16.98		16.93	14.64	9.69	9.68	13.58	1.70	218
10 (250) JIS B2200 - 40K, SO / RF	8705 _ _ _ 100CT	19.54		19.34	19.43			18.70	14.64	9.69	9.68	13.98	1.70	382
10 (250) AS4087 PN16, SO / RF	8705 _ _ _ 100CU	15.00		14.63	14.73	14.75		15.94	14.64	9.69	9.68	12.91	2.00	96
10 (250) AS4087 PN21, SO / RF	8705 _ _ _ 100CW	15.00		14.63	14.73	14.75		16.93	14.64	9.69	9.68	13.74	2.00	176
10 (250) AS4087 PN35, SO / RF	8705 _ _ _ 100CY	17.13		16.86	16.95	16.98		16.93	14.64	9.69	9.68	12.24	2.00	299
12 (300) ASME - 150 , SO / RF	8705 _ _ _ 120C1	18.01	17.90	17.68	17.78	17.80	18.00	19.00	16.80	10.77	10.76	15.00	2.00	231
12 (300) ASME - 300 , SO / RF	8705 _ _ _ 120C3	20.14	20.02	19.80	19.89	19.92	20.14	20.50	16.80	10.77	10.76	15.00	2.00	387
12 (300) ASME - 600 DERAT. , SO / RF	8705 _ _ _ 120C6	22.08	22.10	21.88	21.98	22.00		22.00	16.80	10.77	10.76	15.00	2.00	623
12 (300) DIN - PN10, SO / RF	8705 _ _ _ 120CD	18.01	17.90	17.68	17.78	17.80	18.00	17.52	16.80	10.77	10.76	14.57	2.00	178
12 (300) DIN - PN16, SO / RF	8705 _ _ _ 120CE	18.01	17.90	17.68	17.78	17.80	18.00	18.11	16.80	10.77	10.76	14.88	2.00	192
12 (300) DIN - PN25, SO / RF	8705 _ _ _ 120CF	18.01	17.90	17.68	17.78	17.80	18.00	19.09	16.80	10.77	10.76	15.55	2.00	242
12 (300) DIN - PN40, SO / RF	8705 _ _ _ 120CH	20.14		19.80	19.89	19.92	20.14	20.28	16.80	10.77	10.76	16.14	2.00	351
12 (300) AS2129 TABLE D, SO / RF	8705 _ _ _ 120CK	18.01		17.68	17.78	17.80		17.91	16.80	10.77	10.76	14.88	2.00	172
12 (300) AS2129 TABLE E, SO / RF	8705 _ _ _ 120CL	18.01		17.68	17.78	17.80		17.91	16.80	10.77	10.76	14.72	2.00	185
12 (300) JIS B2200 - 10K, SO / RF	8705 _ _ _ 120CP	18.01		17.68	17.78	17.80		17.52	16.80	10.77	10.76	14.49	2.00	166
12 (300) JIS B2200 - 20K, SO / RF	8705 _ _ _ 120CR	20.14		19.80	19.89	19.92		18.90	16.80	10.77	10.76	15.55	2.00	285
12 (300) JIS B2200 - 40K, SO / RF	8705 _ _ _ 120CT	22.08		21.88	21.98	21.78		21.26	16.80	10.77	10.76	16.14	3.13	546
12 (300) AS4087 PN16, SO / RF	8705 _ _ _ 120CU	18.01		17.68	17.78	17.80		17.91	16.80	10.77	10.76	14.88	2.00	138
12 (300) AS4087 PN21, SO / RF	8705 _ _ _ 120CW	18.01		17.68	17.78	17.80		19.29	16.80	10.77	10.76	15.98	2.00	225
12 (300) AS4087 PN35, SO / RF	8705 _ _ _ 120CY	20.14		19.80	19.89	19.92		19.29	16.80	10.77	10.76	14.25	2.00	370

Table 38: 8705-M Flanged sensor 14-in. to 20-in. slip-on flanges—low pressure (P ≤ Class 300)—Inches

SIZE, DESCRIPTION	MODEL NUMBER 	OVERALL LENGTH						FLANGE Ø DIM "B"	BODY Ø DIM "C"	DIM "D" CL to TA		LINER Ø ON FACE DIM "J"	LIFT RING HEIGHT DIM "K"	FLOW TUBE WEIGHT (lbs.)
		DIM "A" PTFE	DIM "A" ETFE	DIM "A" NEOPRENE	DIM "A" LIMATEX	DIM "A" POLY	DIM "A" PFA			STYLE A	STYLE B			
14 (350) ASME - 150 , SO / RF	8705 _ _ _ 140C1	20.91	20.93	20.71	20.80	20.83	21.00	21.00	18.92	11.83	11.82	16.25	2.00	300
14 (350) ASME - 300 , SO / RF	8705 _ _ _ 140C3	23.16	23.18	22.96	23.05	23.08		23.00	18.92	11.83	11.82	16.25	2.00	517
14 (350) ASME - 600 DERAT., SO / RF	8705 _ _ _ 140C6	25.74						23.75	18.92	11.83	11.82	16.25	2.00	773
14 (350) DIN - PN10, SO / RF	8705 _ _ _ 140CD	20.91	20.93	20.71	20.80	20.83	21.00	19.88	18.92	11.83	11.82	16.93	2.00	252
14 (350) DIN - PN16, SO / RF	8705 _ _ _ 140CE	20.91		20.71	20.80	20.83	21.00	20.47	18.92	11.83	11.82	17.24	2.00	276
14 (350) DIN - PN25, SO / RF	8705 _ _ _ 140CF	20.91		20.71	20.80	20.83		21.85	18.92	11.83	11.82	17.72	2.00	359
14 (350) DIN - PN40, SO / RF	8705 _ _ _ 140CH	23.16		22.96	23.05	23.08		22.83	18.92	11.83	11.82	18.31	2.00	480
14 (350) AS2129 TABLE D, SO / RF	8705 _ _ _ 140CK	20.91		20.71	20.80	20.83		20.67	18.92	11.83	11.82	17.24	2.00	230
14 (350) AS2129 TABLE E, SO / RF	8705 _ _ _ 140CL	20.91		20.71	20.80	20.83		20.67	18.92	11.83	11.82	17.24	2.00	257
14 (350) JIS B2200 - 10K, SO / RF	8705 _ _ _ 140CP	20.91		20.71	20.80	20.83		19.29	18.92	11.83	11.82	16.26	2.00	221
14 (350) JIS B2200 - 20K, SO / RF	8705 _ _ _ 140CR	23.16		22.96	23.05	23.08		21.26	18.92	11.83	11.82	17.32	2.00	385
14 (350) JIS B2200 - 40K, SO / RF	8705 _ _ _ 140CT	25.74		25.54	25.64			23.03	18.92	11.83	11.82	17.91	2.00	702
14 (350) AS4087 PN16, SO / RF	8705 _ _ _ 140CU	20.91		20.71	20.80	20.83		20.67	18.92	11.83	11.82	17.24	2.00	219
14 (350) AS4087 PN21, SO / RF	8705 _ _ _ 140CW	20.91		20.71	20.80	20.83		21.65	18.92	11.83	11.82	18.07	2.00	294
14 (350) AS4087 PN35, SO / RF	8705 _ _ _ 140CY	23.16		22.96	23.05	23.08		21.65	18.92	11.83	11.82	16.50	2.00	497
16 (400) ASME - 150 , SO / RF	8705 _ _ _ 160C1	23.88	23.90	23.68	23.77	23.80		23.50	20.94	12.84	12.83	18.50	3.13	388
16 (400) ASME - 300 , SO / RF	8705 _ _ _ 160C3	26.13		25.93	26.02	26.05		25.50	20.94	12.84	12.83	18.50	3.13	705
16 (400) ASME - 600 DERAT., SO / RF	8705 _ _ _ 160C6	29.24						27.00	20.94	12.84	12.83	18.50	3.13	1102
16 (400) DIN - PN10, SO / RF	8705 _ _ _ 160CD	23.88	23.90	23.68	23.77	23.80		22.24	20.94	12.84	12.83	18.98	3.13	318
16 (400) DIN - PN16, SO / RF	8705 _ _ _ 160CE	23.88	23.90	23.68	23.77	23.80		22.83	20.94	12.84	12.83	19.28	3.13	354
16 (400) DIN - PN25, SO / RF	8705 _ _ _ 160CF	26.13		25.93	26.02	26.05		24.41	20.94	12.84	12.83	19.88	3.13	581
16 (400) DIN - PN40, SO / RF	8705 _ _ _ 160CH	26.13		25.93	26.02	26.05		25.98	20.94	12.84	12.83	21.06	3.13	696
16 (400) AS2129 TABLE D, SO / RF	8705 _ _ _ 160CK	23.88		23.68	23.77	23.80		22.83	20.94	12.84	12.83	19.25	3.13	283
16 (400) AS2129 TABLE E, SO / RF	8705 _ _ _ 160CL	23.88		23.68	23.77	23.80		22.83	20.94	12.84	12.83	19.25	3.13	327
16 (400) JIS B2200- 10K, SO / RF	8705 _ _ _ 160CP	23.88		23.68	23.77	23.80		22.05	20.94	12.84	12.83	18.70	2.00	296
16 (400) JIS B2200 - 20K, SO / RF	8705 _ _ _ 160CR	26.13		25.93	26.02	26.05		23.82	20.94	12.84	12.83	19.49	2.00	561
16 (400) JIS B2200 - 40K, SO / RF	8705 _ _ _ 160CT	29.24		29.04	29.14			25.39	20.94	12.84	12.83	20.28	2.00	961
16 (400) AS4087 PN16, SO / RF	8705 _ _ _ 160CU	23.88		23.68	23.77	23.80		22.83	20.94	12.84	12.83	19.25	3.13	262
16 (400) AS4087 PN21, SO / RF	8705 _ _ _ 160CW	23.88		23.68	23.77	23.80		24.02	20.94	12.84	12.83	20.31	3.13	387
16 (400) AS4087 PN35, SO / RF	8705 _ _ _ 160CY	26.13		25.93	26.02	26.05		24.02	20.94	12.84	12.83	19.02	3.13	631
18 (450) ASME - 150 , SO / RF	8705 _ _ _ 180C1	26.85		26.65	26.74	26.77		25.00	23.46	14.1	14.09	21	3.13	451
18 (450) ASME - 300 , SO / RF	8705 _ _ _ 180C3	29.97		29.77	29.86	29.89		28.00	23.46	14.1	14.09	21	3.13	907
18 (450) ASME - 600 DERAT., SO / RF	8705 _ _ _ 180C6	32.72						29.25	23.46	14.1	14.09	21	3.13	1407
18 (450) DIN - PN10, SO / RF	8705 _ _ _ 180CD	26.85		26.65	26.74	26.77		24.21	23.46	14.1	14.09	20.94	3.13	381
18 (450) DIN - PN16, SO / RF	8705 _ _ _ 180CE	26.85		26.65	26.74	26.77		25.20	23.46	14.1	14.09	21.65	3.13	434
18 (450) DIN - PN25, SO / RF	8705 _ _ _ 180CF	29.97		29.77	29.86	29.89		26.38	23.46	14.1	14.09	21.85	3.13	744
18 (450) DIN - PN40, SO / RF	8705 _ _ _ 180CH	29.97		29.77	29.86	29.89		26.97	23.46	14.1	14.09	22.05	3.13	817
18 (450) AS2129 TABLE D, SO / RF	8705 _ _ _ 180CK	26.85		26.65	26.74	26.77		25.20	23.46	14.1	14.09	20.94	3.13	356
18 (450) AS2129 TABLE E, SO / RF	8705 _ _ _ 180CL	26.85		26.65	26.74	26.77		25.20	23.46	14.1	14.09	21.73	3.13	414
18 (450) JIS B2200- 10K, SO / RF	8705 _ _ _ 180CP	26.85		26.65	26.74	26.77		24.41	23.46	14.1	14.09	20.87	3.13	373
18 (450) JIS B2200 - 20K, SO / RF	8705 _ _ _ 180CR	29.97		29.77	29.86	29.89		26.57	23.46	14.1	14.09	22.05	3.13	751
18 (450) AS4087 PN16, SO / RF	8705 _ _ _ 180CU	26.85		26.65	26.74	26.77		25.20	23.46	14.1	14.09	21.73	3.13	323
18 (450) AS4087 PN21, SO / RF	8705 _ _ _ 180CW	26.85		26.65	26.74	26.77		26.57	23.46	14.1	14.09	22.48	3.13	453
18 (450) AS4087 PN35, SO / RF	8705 _ _ _ 180CY	29.97		29.77	29.86	29.89		26.57	23.46	14.1	14.09	20.98	3.13	917
20 (500) ASME - 150 , SO / RF	8705 _ _ _ 200C1	29.78		29.58	29.67	29.70		27.50	25.48	15.11	15.1	23	3.13	569
20 (500) ASME - 300 , SO / RF	8705 _ _ _ 200C3	33.04		32.84	32.93	32.96		30.50	25.48	15.11	15.1	23	3.13	1127
20 (500) ASME - 600 DERAT., SO / RF	8705 _ _ _ 200C6	36.85						32.00	25.48	15.11	15.1	23	3.13	1824
20 (500) DIN - PN10, SO / RF	8705 _ _ _ 200CD	29.78		29.58	29.67	29.70		26.38	25.48	15.11	15.1	23.03	3.13	473
20 (500) DIN - PN16, SO / RF	8705 _ _ _ 200CE	29.78		29.58	29.67	29.70		28.15	25.48	15.11	15.1	24.02	3.13	567
20 (500) DIN - PN25, SO / RF	8705 _ _ _ 200CF	33.04		32.84	32.93	32.96		28.74	25.48	15.11	15.1	24.21	3.13	932
20 (500) DIN - PN40, SO / RF	8705 _ _ _ 200CH	33.04		32.84	32.93	32.96		29.72	25.48	15.11	15.1	24.21	3.13	1013
20 (500) AS2129 TABLE D, SO / RF	8705 _ _ _ 200CK	29.78		29.58	29.67	29.70		27.76	25.48	15.11	15.1	23.98	3.13	471
20 (500) AS2129 TABLE E, SO / RF	8705 _ _ _ 200CL	29.78		29.58	29.67	29.70		27.76	25.48	15.11	15.1	23.98	3.13	528
20 (500) JIS B2200 - 10K, SO / RF	8705 _ _ _ 200CP	29.78		29.58	29.67	29.70		26.57	25.48	15.11	15.1	23.03	3.13	453
20 (500) JIS B2200 - 20K, SO / RF	8705 _ _ _ 200CR	33.04		32.84	32.93	32.96		28.74	25.48	15.11	15.1	24.21	3.13	919
20 (500) AS4087 PN16, SO / RF	8705 _ _ _ 200CU	29.78		29.58	29.67	29.70		27.76	25.48	15.11	15.1	23.98	3.13	453
20 (500) AS4087 PN21, SO / RF	8705 _ _ _ 200CW	29.78		29.58	29.67	29.70		28.94	25.48	15.11	15.1	24.96	3.13	627
20 (500) AS4087 PN35, SO / RF	8705 _ _ _ 200CY	33.04		32.84	32.93	32.96		28.94	25.48	15.11	15.1	23.5	3.13	1074

Table 39: 8705-M Flanged sensor 24-in. to 36-in. slip-on flanges—low pressure (P ≤ Class 300)—Inches

SIZE, DESCRIPTION	MODEL NUMBER 	OVERALL LENGTH						FLANGE Ø DIM "B"	BODY Ø DIM "C"	DIM "D" CL 1 ₀ TA		LINER Ø ON FACE DIM "J"	LIFT RING HEIGHT DIM "K"	FLOW TUBE WEIGHT (lbs.)
		DIM "A" PTFE	DIM "A" ETFE	DIM "A" NEOPRENE	DIM "A" LINATEX	DIM "A" POLY	DIM "A" PFA			STYLE A	STYLE B			
24 (600) ASME - 150 , SO / RF	8705 _ _ _ 240C1	35.75		35.55	35.64	35.67		32.00	30.03	17.39	17.38	27.25	3.13	828
24 (600) ASME - 300 , SO / RF	8705 _ _ _ 240C3	39.38		39.18	39.27	39.30		36.00	30.03	17.39	17.38	27.25	3.13	1729
24 (600) ASME - 600 DERAT., SO / RF	8705 _ _ _ 240C6	41.35						37.00	30.03	17.39	17.38	27.25	3.13	2690
24 (600) DIN - PN10, SO / RF	8705 _ _ _ 240CD	35.75		35.55	35.64	35.67		30.71	30.03	17.39	17.38	26.97	3.13	661
24 (600) DIN - PN16, SO / RF	8705 _ _ _ 240CE	35.75		35.55	35.64	35.67		33.07	30.03	17.39	17.38	28.54	3.13	832
24 (600) DIN - PN25, SO / RF	8705 _ _ _ 240CF	39.38		39.18	39.27	39.30		33.27	30.03	17.39	17.38	28.35	3.13	1352
24 (600) DIN - PN40, SO / RF	8705 _ _ _ 240CH	39.38		39.18	39.27	39.30		35.04	30.03	17.39	17.38	28.94	3.13	1628
24 (600) AS2129 TABLE D, SO / RF	8705 _ _ _ 240CK	35.75		35.55	35.64	35.67		32.48	30.03	17.39	17.38	28.35	3.13	692
24 (600) AS2129 TABLE E, SO / RF	8705 _ _ _ 240CL	35.75		35.55	35.64	35.67		32.48	30.03	17.39	17.38	28.23	3.13	814
24 (600) JIS B2200 - 10K, SO / RF	8705 _ _ _ 240CP	35.75		35.55	35.64	35.67		31.30	30.03	17.39	17.38	27.17	3.13	659
24 (600) JIS B2200 - 20K, SO / RF	8705 _ _ _ 240CR	39.38		39.18	39.27	39.30		33.27	30.03	17.39	17.38	28.35	3.13	1353
24 (600) AS4087 PN16, SO / RF	8705 _ _ _ 240CU	35.75		35.55	35.64	35.67		32.48	30.03	17.39	17.38	28.35	3.13	709
24 (600) AS4087 PN21, SO / RF	8705 _ _ _ 240CW	39.38		39.18	39.27	39.30		33.46	30.03	17.39	17.38	29.09	3.13	1293
24 (600) AS4087 PN35, SO / RF	8705 _ _ _ 240CY	39.38		39.18	39.27	39.30		33.46	30.03	17.39	17.38	27.52	3.13	1528
30 (750) AWWA CLASS D, SO / FF	8705 _ _ _ 300C1	37.00		36.80	36.89	37.04		38.75	35.50	20.13	20.11	33.75	3.13	897
30 (750) MSS SP44 - 150 , SO / RF	8705 _ _ _ 300C2	41.56		41.36	41.45	41.48		38.75	35.50	20.13	20.11	33.75	3.13	1561
30 (750) MSS SP44 - 300 , SO / RF	8705 _ _ _ 300C3	47.25		47.05	47.14	47.17		43.00	35.50	20.13	20.11	33.75	3.13	2950
30 (750) AS2129 TABLE D, SO / RF	8705 _ _ _ 300CK	37.00		36.80	36.89	37.04		39.17	35.50	20.13	20.11	34.96	3.13	1036
30 (750) AS2129 TABLE E, SO / RF	8705 _ _ _ 300CL	41.56		41.36	41.45	41.48		39.17	35.50	20.13	20.11	33.75	3.13	1275
30 (750) AS4087 PN16, SO / RF	8705 _ _ _ 300CU	37.00		36.80	36.89	36.92		39.17	35.50	20.13	20.11	34.96	3.13	1083
30 (750) AS4087 PN21, SO / RF	8705 _ _ _ 300CW	41.56		41.36	41.45	41.48		39.96	35.50	20.13	20.11	3.00	3.13	1071
30 (750) AS4087 PN35, SO / RF	8705 _ _ _ 300CY	47.25		47.05	47.14	47.17		39.96	35.50	20.13	20.11	35.35	3.13	2452
36 (900) AWWA CLASS D, SO / FF	8705 _ _ _ 360C1	40.63		40.43	40.52	40.67		46.00	43.37	24.00	24.05	40.25	3.13	1267
36 (900) MSS SP44 - 150 , SO / RF	8705 _ _ _ 360C2	47.25		47.05	47.14	47.17		46.00	43.37	24.00	24.05	40.25	3.13	2550
36 (900) MSS SP44 - 300 , SO / RF	8705 _ _ _ 360C3	53.17		52.97	53.06	53.09		50.00	43.37	24.00	24.05	40.25	3.38	4584
36 (900) AS2129 TABLE D, SO / RF	8705 _ _ _ 360CK	40.63		40.43	40.52	40.67		46.26	43.37	24.00	24.05	41.34	3.13	1515
36 (900) AS2129 TABLE E, SO / RF	8705 _ _ _ 360CL	47.25		47.05	47.14	47.17		46.26	43.37	24.00	24.05	41.34	3.13	2105
36 (900) AS4087 PN16, SO / RF	8705 _ _ _ 360CU	40.63		40.43	40.52	40.55		46.26	43.37	24.00	24.05	41.34	3.13	1559
36 (900) AS4087 PN21, SO / RF	8705 _ _ _ 360CW	47.25		47.05	47.14	47.17		46.65	43.37	24.00	24.05	41.73	3.13	2060
36 (900) AS4087 PN35, SO / RF	8705 _ _ _ 360CY	53.17		52.97	53.06	53.09		46.65	43.37	24.00	24.05	40.55	3.38	3700

Table 40: 8705-M Flanged sensor DN 80mm to 150mm slip-on flanges—low pressure (P ≤ Class 300)—Millimeters

SIZE, DESCRIPTION	MODEL NUMBER 	OVERALL LENGTH						FLANGE Ø DIM "B"	BODY Ø DIM "C"	DIM "D" CL Fo TA		LINER Ø ON FACE DIM "J"	LIFT RING HEIGHT DIM "K"	FLOW TUBE WEIGHT (kg)
		DIM "A" PTFE	DIM "A" ETFE	DIM "A" NEOPRENE	DIM "A" LINATEX	DIM "A" POLY	DIM "A" PFA			STYLE A	STYLE B			
3 (80) ASME - 150 , SO / RF	8705 _ _ _ 030C1	200	200	197	199	200	199	190	183	148	152	127	43	15
3 (80) ASME - 300 , SO / RF	8705 _ _ _ 030C3	219	219	216	219	219	218	209	183	148	152	127	43	19
3 (80) ASME - 600 DERAT., SO / RF	8705 _ _ _ 030C6	315	315	312	315	315		209	183	148	152	127	43	24
3 (80) DIN - PN40, SO / RF	8705 _ _ _ 030CH	200	200	197	199	200	200	200	183	148	152	138	43	17
3 (80) AS2129 TABLE D, SO / RF	8705 _ _ _ 030CK	200		197	199	200		185	183	148	152	122	43	11
3 (80) AS2129 TABLE E, SO / RF	8705 _ _ _ 030CL	200		197	199	200		185	183	148	152	122	43	11
3 (80) JIS B2200 - 10K, SO / RF	8705 _ _ _ 030CP	200		197	199	200		185	183	148	152	126	43	13
3 (80) JIS B2200 - 20K, SO / RF	8705 _ _ _ 030CR	200		197	199	200		200	183	148	152	132	43	16
3 (80) JIS B2200 - 40K, SO / RF	8705 _ _ _ 030CT	315		312	315	315		210	183	148	152	140	43	24
3 (80) AS4087 PN16, SO / RF	8705 _ _ _ 030CU	200		197	199	200		185	183	148	152	122	43	9
3 (80) AS4087 PN21, SO / RF	8705 _ _ _ 030CW	200		197	199	200		205	183	148	152	141	43	25
3 (80) AS4087 PN35, SO / RF	8705 _ _ _ 030CY	200		197	199	200		205	183	148	152	141	43	49
4 (100) ASME - 150 , SO / RF	8705 _ _ _ 040C1	250	250	246	249	250	250	229	201	157	160	157	43	20
4 (100) ASME - 300 , SO / RF	8705 _ _ _ 040C3	276	276	273	275	276	276	254	201	157	160	157	43	29
4 (100) ASME - 600 DERAT., SO / RF	8705 _ _ _ 040C6	326	326	323	325	326		273	201	157	160	157	43	42
4 (100) DIN - PN16, SO / RF	8705 _ _ _ 040CE	250	249	246	249	249	249	220	201	157	160	158	43	19
4 (100) DIN - PN40, SO / RF	8705 _ _ _ 040CH	250	249	246	249	249	249	235	201	157	160	162	43	22
4 (100) AS2129 TABLE D, SO / RF	8705 _ _ _ 040CK	250	250	246	249	250		215	201	157	160	154	43	14
4 (100) AS2129 TABLE E, SO / RF	8705 _ _ _ 040CL	250	250	246	249	250		215	201	157	160	154	43	15
4 (100) JIS B2200 - 10K, SO / RF	8705 _ _ _ 040CP	250		246	249	250		210	201	157	160	151	43	16
4 (100) JIS B2200 - 20K, SO / RF	8705 _ _ _ 040CR	250		246	249	250		225	201	157	160	160	43	20
4 (100) JIS B2200 - 40K, SO / RF	8705 _ _ _ 040CT	326		323	325	326		250	201	157	160	165	43	34
4 (100) AS4087 PN16, SO / RF	8705 _ _ _ 040CU	250		246	249	250		215	201	157	160	154	43	13
4 (100) AS4087 PN21, SO / RF	8705 _ _ _ 040CW	250		246	249	250		230	201	157	160	167	43	31
4 (100) AS4087 PN35, SO / RF	8705 _ _ _ 040CY	250		246	249	250		230	201	157	160	167	43	54
5 (125) ASME - 150 , SO / RF	8705 _ _ _ 050C1	249		247				254	244	178	182	186	43	24
5 (125) ASME - 300 , SO / RF	8705 _ _ _ 050C3	278		276				279	244	178	182	186	43	40
5 (125) ASME - 600 DERAT., SO / RF	8705 _ _ _ 050C6	327		325				330	244	178	182	186	43	71
5 (125) DIN - PN16, SO / RF	8705 _ _ _ 050CE	249		241				250	244	178	182	188	43	25
5 (125) DIN - PN40, SO / RF	8705 _ _ _ 050CH	249		247				270	244	178	182	188	43	29
5 (125) AS2129 TABLE D, SO / RF	8705 _ _ _ 050CK	249		247				255	244	178	182	186	43	20
5 (125) AS2129 TABLE E, SO / RF	8705 _ _ _ 050CL	249		247				255	244	178	182	186	43	20
5 (125) JIS B2200 - 10K, SO / RF	8705 _ _ _ 050CP	249		247				250	244	178	182	182	43	22
5 (125) JIS B2200 - 20K, SO / RF	8705 _ _ _ 050CR	249		247				270	244	178	182	195	43	29
5 (125) JIS B2200 - 40K, SO / RF	8705 _ _ _ 050CT	278		276				300	244	178	182	200	43	51
6 (150) ASME - 150 , SO / RF	8705 _ _ _ 060C1	300	298	295	297	298	300	279	253	185	187	216	43	31
6 (150) ASME - 300 , SO / RF	8705 _ _ _ 060C3	332	331	327	330	330	332	318	253	185	187	216	43	53
6 (150) ASME - 600 DERAT., SO / RF	8705 _ _ _ 060C6	361	360	357	359	360		356	253	185	187	216	43	81
6 (150) DIN - PN16, SO / RF	8705 _ _ _ 060CE	300	298	295	297	298	300	285	253	185	187	212	43	31
6 (150) DIN - PN25, SO / RF	8705 _ _ _ 060CF	300	300	296	299	299	301	300	253	185	187	218	43	38
6 (150) DIN - PN40, SO / RF	8705 _ _ _ 060CH	332	331	327	330	330	332	300	253	185	187	218	43	43
6 (150) AS2129 TABLE D, SO / RF	8705 _ _ _ 060CK	300		295	297	298		280	253	185	187	211	43	24
6 (150) AS2129 TABLE E, SO / RF	8705 _ _ _ 060CL	300		295	297	298		280	253	185	187	207	43	26
6 (150) JIS B2200 - 10K, SO / RF	8705 _ _ _ 060CP	300		295	297	298		280	253	185	187	212	43	29
6 (150) JIS B2200 - 20K, SO / RF	8705 _ _ _ 060CR	300		295	297	298		305	253	185	187	230	43	37
6 (150) JIS B2200 - 40K, SO / RF	8705 _ _ _ 060CT	361		357	359	360		355	253	185	187	240	43	73
6 (150) AS4087 PN16, SO / RF	8705 _ _ _ 060CU	300		295	297	298		280	253	185	187	211	43	21
6 (150) AS4087 PN21, SO / RF	8705 _ _ _ 060CW	300		295	297	298		305	253	185	187	232	43	45
6 (150) AS4087 PN35, SO / RF	8705 _ _ _ 060CY	300		295	297	298		305	253	185	187	232	43	84

Table 41: 8705-M Flanged sensor DN 200mm to 300mm slip-on flanges—low pressure (P ≤ Class 300)—Millimeters

SIZE, DESCRIPTION	MODEL NUMBER 	OVERALL LENGTH						FLANGE Ø DIM "B"	BODY Ø DIM "C"	DIM "D" CL to TA		LINER Ø ON FACE DIM "J"	LIFT RING HEIGHT DIM "K"	FLOW TUBE WEIGHT (kg)
		DIM "A" PTFE	DIM "A" ETFE	DIM "A" NEOPRENE	DIM "A" LINATEX	DIM "A" POLY	DIM "A" PFA			STYLE A	STYLE B			
8 (200) ASME - 150 , SO / RF	8705 _ _ _ 080C1	350	348	344	346	347	350	342.90	303	210	211	270	43	48
8 (200) ASME - 300 , SO / RF	8705 _ _ _ 080C3	396	395	392	394	395	396	381.00	303	210	211	270	43	83
8 (200) ASME - 600 DERAT., SO / RF	8705 _ _ _ 080C6	425	423	420	422	423		419.10	303	210	211	270	43	123
8 (200) DIN - PN10, SO / RF	8705 _ _ _ 080CD	350	348	344	346	347	350	340.11	303	210	211	268	43	44
8 (200) DIN - PN16, SO / RF	8705 _ _ _ 080CE	350	348	344	346	347	350	340.11	303	210	211	268	43	43
8 (200) DIN - PN25, SO / RF	8705 _ _ _ 080CF	350	348	344	346	347	350	359.92	303	210	211	278	43	54
8 (200) DIN - PN40, SO / RF	8705 _ _ _ 080CH	396	395	392	394	395	396	374.90	303	210	211	285	43	72
8 (200) AS2129 TABLE D, SO / RF	8705 _ _ _ 080CK	350		344	346	347		335.03	303	210	211	268	43	35
8 (200) AS2129 TABLE E, SO / RF	8705 _ _ _ 080CL	350		344	346	347		335.03	303	210	211	264	43	39
8 (200) JIS B2200 - 10K, SO / RF	8705 _ _ _ 080CP	353		344	346	347		330.00	303	210	211	262	43	37
8 (200) JIS B2200 - 20K, SO / RF	8705 _ _ _ 080CR	396		392	394	395		350.00	303	210	211	275	43	61
8 (200) JIS B2200 - 40K, SO / RF	8705 _ _ _ 080CT	425		420	422	423		405.00	303	210	211	290	43	105
8 (200) AS4087 PN16, SO / RF	8705 _ _ _ 080CU	350		344	346	347		335.00	303	210	211	268	43	33
8 (200) AS4087 PN21, SO / RF	8705 _ _ _ 080CW	350		344	346	347		370.00	303	210	211	296	43	62
8 (200) AS4087 PN35, SO / RF	8705 _ _ _ 080CY	396		392	394	395		370.00	303	210	211	260	43	109
10 (250) ASME - 150 , SO / RF	8705 _ _ _ 100C1	381	377	372	374	375	381	406.40	372	246	246	324	51	69
10 (250) ASME - 300 , SO / RF	8705 _ _ _ 100C3	435	434	428	431	431	435	444.50	372	246	246	324	51	120.9
10 (250) ASME - 600 DERAT., SO / RF	8705 _ _ _ 100C6	496	497	491	494	494		508.00	372	246	246	324	51	209.6
10 (250) DIN - PN10, SO / RF	8705 _ _ _ 100CD	381	377	372	374	375	381	394.97	372	246	246	320	51	61.0
10 (250) DIN - PN16, SO / RF	8705 _ _ _ 100CE	381	377	372	374	375	381	404.88	372	246	246	320	51	62.7
10 (250) DIN - PN25, SO / RF	8705 _ _ _ 100CF	381	377	372	374	375	381	424.94	372	246	246	335	51	78.9
10 (250) DIN - PN40, SO / RF	8705 _ _ _ 100CH	435		428	431	431	435	450.09	372	246	246	345	51	110.7
10 (250) AS2129 TABLE D, SO / RF	8705 _ _ _ 100CK	381		372	374	375		404.88	372	246	246	328	51	55.5
10 (250) AS2129 TABLE E, SO / RF	8705 _ _ _ 100CL	381		372	374	375		404.88	372	246	246	328	51	62.0
10 (250) JIS B2200 - 10K, SO / RF	8705 _ _ _ 100CP	381		372	374	375		400.00	372	246	246	324	43	58.5
10 (250) JIS B2200 - 20K, SO / RF	8705 _ _ _ 100CR	435		428	431	431		430.00	372	246	246	345	43	98.7
10 (250) JIS B2200 - 40K, SO / RF	8705 _ _ _ 100CT	496		491	494			475.00	372	246	246	355	43	173.5
10 (250) AS4087 PN16, SO / RF	8705 _ _ _ 100CU	381		372	374	375		405.00	372	246	246	328	51	43.7
10 (250) AS4087 PN21, SO / RF	8705 _ _ _ 100CW	381		372	374	375		430.00	372	246	246	349	51	80.0
10 (250) AS4087 PN35, SO / RF	8705 _ _ _ 100CY	435		428	431	431		430.00	372	246	246	311	51	135.7
12 (300) ASME - 150 , SO / RF	8705 _ _ _ 120C1	458	455	449	452	452	457	482.60	427	274	273	381	51	104.9
12 (300) ASME - 300 , SO / RF	8705 _ _ _ 120C3	512	508	503	505	506	512	520.70	427	274	273	381	51	175.3
12 (300) ASME - 600 DERAT., SO / RF	8705 _ _ _ 120C6	561	561	556	558	559		558.80	427	274	273	381	51	282.7
12 (300) DIN - PN10, SO / RF	8705 _ _ _ 120CD	458	455	449	452	452	457	445.01	427	274	273	370	51	80.9
12 (300) DIN - PN16, SO / RF	8705 _ _ _ 120CE	458	455	449	452	452	457	459.99	427	274	273	378	51	87.1
12 (300) DIN - PN25, SO / RF	8705 _ _ _ 120CF	458	455	449	452	452	457	484.89	427	274	273	395	51	109.8
12 (300) DIN - PN40, SO / RF	8705 _ _ _ 120CH	512		503	505	506	512	515.11	427	274	273	410	51	159.4
12 (300) AS2129 TABLE D, SO / RF	8705 _ _ _ 120CK	458		449	452	452		454.91	427	274	273	378	51	78.0
12 (300) AS2129 TABLE E, SO / RF	8705 _ _ _ 120CL	458		449	452	452		454.91	427	274	273	374	51	84.0
12 (300) JIS B2200 - 10K, SO / RF	8705 _ _ _ 120CP	458		449	452	452		445.00	427	274	273	368	51	75.4
12 (300) JIS B2200 - 20K, SO / RF	8705 _ _ _ 120CR	512		503	505	506		480.00	427	274	273	395	51	129.1
12 (300) JIS B2200 - 40K, SO / RF	8705 _ _ _ 120CT	561		556	558	553		540.00	427	274	273	410	80	247.6
12 (300) AS4087 PN16, SO / RF	8705 _ _ _ 120CU	458		449	452	452		455.00	427	274	273	378	51	62.5
12 (300) AS4087 PN21, SO / RF	8705 _ _ _ 120CW	458		449	452	452		490.00	427	274	273	406	51	102.2
12 (300) AS4087 PN35, SO / RF	8705 _ _ _ 120CY	512		503	505	506		490.00	427	274	273	362	51	167.8

Table 42: 8705-M Flanged sensor DN 350mm to 500mm slip-on flanges—low pressure (P ≤ Class 300)—Millimeters

SIZE, DESCRIPTION	MODEL NUMBER 	OVERALL LENGTH							FLANGE Ø DIM "B"	BODY Ø DIM "C"	DIM "D" CL to TA		LINER Ø ON FACE DIM "J"	LIFT RING HEIGHT DIM "K"	FLOW TUBE WEIGHT (kg)
		DIM "A" PTFE	DIM "A" ETFE	DIM "A" NEOPRENE	DIM "A" LINATEX	DIM "A" POLY	DIM "A" PFA	STYLE A			STYLE B				
14 (350) ASME - 150 , SO / RF	8705 _ _ _ 140C1	531	532	526	528	529	533	533	481	300	300	413	51	136	
14 (350) ASME - 300 , SO / RF	8705 _ _ _ 140C3	588	589	583	586	586		584	481	300	300	413	51	234	
14 (350) ASME - 600 DERAT. , SO / RF	8705 _ _ _ 140C6	654						603	481	300	300	413	51	351	
14 (350) DIN - PN10, SO / RF	8705 _ _ _ 140CD	531	532	526	528	529	533	505	481	300	300	430	51	114	
14 (350) DIN - PN16, SO / RF	8705 _ _ _ 140CE	531		526	528	529	533	520	481	300	300	438	51	125	
14 (350) DIN - PN25, SO / RF	8705 _ _ _ 140CF	531		526	528	529		555	481	300	300	450	51	163	
14 (350) DIN - PN40, SO / RF	8705 _ _ _ 140CH	588		583	586	586		580	481	300	300	465	51	218	
14 (350) AS2129 TABLE D, SO / RF	8705 _ _ _ 140CK	531		526	528	529		525	481	300	300	438	51	104	
14 (350) AS2129 TABLE E, SO / RF	8705 _ _ _ 140CL	531		526	528	529		525	481	300	300	438	51	116	
14 (350) JIS B2200 - 10K, SO / RF	8705 _ _ _ 140CP	531		526	528	529		490	481	300	300	413	51	100	
14 (350) JIS B2200 - 20K, SO / RF	8705 _ _ _ 140CR	588		583	586	586		540	481	300	300	440	51	175	
14 (350) JIS B2200 - 40K, SO / RF	8705 _ _ _ 140CT	654		649	651			585	481	300	300	455	51	318	
14 (350) AS4087 PN16, SO / RF	8705 _ _ _ 140CU	531		526	528	529		525	481	300	300	438	51	99	
14 (350) AS4087 PN21, SO / RF	8705 _ _ _ 140CW	531		526	528	529		550	481	300	300	459	51	133	
14 (350) AS4087 PN35, SO / RF	8705 _ _ _ 140CY	588		583	586	586		550	481	300	300	419	51	226	
16 (400) ASME - 150 , SO / RF	8705 _ _ _ 160C1	607	607	601	604	604		597	532	326	326	470	80	176	
16 (400) ASME - 300 , SO / RF	8705 _ _ _ 160C3	664		659	661	662		648	532	326	326	470	80	320	
16 (400) ASME - 600 DERAT. , SO / RF	8705 _ _ _ 160C6	743						686	532	326	326	470	80	500	
16 (400) DIN - PN10, SO / RF	8705 _ _ _ 160CD	607	607	601	604	604		565	532	326	326	482	80	144	
16 (400) DIN - PN16, SO / RF	8705 _ _ _ 160CE	607	607	601	604	604		580	532	326	326	490	80	161	
16 (400) DIN - PN25, SO / RF	8705 _ _ _ 160CF	664		659	661	662		620	532	326	326	505	80	264	
16 (400) DIN - PN40, SO / RF	8705 _ _ _ 160CH	664		659	661	662		660	532	326	326	535	80	316	
16 (400) AS2129 TABLE D, SO / RF	8705 _ _ _ 160CK	607		601	604	604		580	532	326	326	489	80	129	
16 (400) AS2129 TABLE E, SO / RF	8705 _ _ _ 160CL	607		601	604	604		580	532	326	326	489	80	148	
16 (400) JIS B2200 - 10K, SO / RF	8705 _ _ _ 160CP	607		601	604	604		560	532	326	326	475	51	134	
16 (400) JIS B2200 - 20K, SO / RF	8705 _ _ _ 160CR	664		659	661	662		605	532	326	326	495	51	254	
16 (400) JIS B2200 - 40K, SO / RF	8705 _ _ _ 160CT	743		738	740			645	532	326	326	515	51	436	
16 (400) AS4087 PN16, SO / RF	8705 _ _ _ 160CU	607		601	604	604		580	532	326	326	489	80	119	
16 (400) AS4087 PN21, SO / RF	8705 _ _ _ 160CW	607		601	604	604		610	532	326	326	516	80	175	
16 (400) AS4087 PN35, SO / RF	8705 _ _ _ 160CY	664		659	661	662		610	532	326	326	483	80	286	
18 (450) ASME - 150 , SO / RF	8705 _ _ _ 180C1	682		677	679	680		635	596	358	358	533	80	205	
18 (450) ASME - 300 , SO / RF	8705 _ _ _ 180C3	761		756	758	759		711	596	358	358	533	80	411	
18 (450) ASME - 600 DERAT. , SO / RF	8705 _ _ _ 180C6	831						743	596	358	358	533	80	638	
18 (450) DIN - PN10, SO / RF	8705 _ _ _ 180CD	682		677	679	680		615	596	358	358	532	80	173	
18 (450) DIN - PN16, SO / RF	8705 _ _ _ 180CE	682		677	679	680		640	596	358	358	550	80	197	
18 (450) DIN - PN25, SO / RF	8705 _ _ _ 180CF	761		756	758	759		670	596	358	358	555	80	338	
18 (450) DIN - PN40, SO / RF	8705 _ _ _ 180CH	761		756	758	759		685	596	358	358	560	80	371	
18 (450) AS2129 TABLE D, SO / RF	8705 _ _ _ 180CK	682		677	679	680		640	596	358	358	532	80	161	
18 (450) AS2129 TABLE E, SO / RF	8705 _ _ _ 180CL	682		677	679	680		640	596	358	358	552	80	188	
18 (450) JIS B2200 - 10K, SO / RF	8705 _ _ _ 180CP	682		677	679	680		620	596	358	358	530	80	169	
18 (450) JIS B2200 - 20K, SO / RF	8705 _ _ _ 180CR	761		756	758	759		675	596	358	358	560	80	340	
18 (450) AS4087 PN16, SO / RF	8705 _ _ _ 180CU	682		677	679	680		640	596	358	358	552	80	146	
18 (450) AS4087 PN21, SO / RF	8705 _ _ _ 180CW	682		677	679	680		675	596	358	358	571	80	205	
18 (450) AS4087 PN35, SO / RF	8705 _ _ _ 180CY	761		756	758	759		675	596	358	358	533	80	416	
20 (500) ASME - 150 , SO / RF	8705 _ _ _ 200C1	756		751	754	754		699	647	384	384	584	80	258	
20 (500) ASME - 300 , SO / RF	8705 _ _ _ 200C3	839		834	836	837		775	647	384	384	584	80	511	
20 (500) ASME - 600 DERAT. , SO / RF	8705 _ _ _ 200C6	936						813	647	384	384	584	80	827	
20 (500) DIN - PN10, SO / RF	8705 _ _ _ 200CD	756		751	754	754		670	647	384	384	585	80	215	
20 (500) DIN - PN16, SO / RF	8705 _ _ _ 200CE	756		751	754	754		715	647	384	384	610	80	257	
20 (500) DIN - PN25, SO / RF	8705 _ _ _ 200CF	839		834	836	837		730	647	384	384	615	80	423	
20 (500) DIN - PN40, SO / RF	8705 _ _ _ 200CH	839		834	836	837		754	647	384	384	615	80	459	
20 (500) AS2129 TABLE D, SO / RF	8705 _ _ _ 200CK	756		751	754	754		705	647	384	384	609	80	214	
20 (500) AS2129 TABLE E, SO / RF	8705 _ _ _ 200CL	756		751	754	754		705	647	384	384	609	80	239	
20 (500) JIS B2200 - 10K, SO / RF	8705 _ _ _ 200CP	756		751	754	754		675	647	384	384	585	80	206	
20 (500) JIS B2200 - 20K, SO / RF	8705 _ _ _ 200CR	839		834	836	837		730	647	384	384	615	80	417	
20 (500) AS4087 PN16, SO / RF	8705 _ _ _ 200CU	756		751	754	754		705	647	384	384	609	80	205	
20 (500) AS4087 PN21, SO / RF	8705 _ _ _ 200CW	756		751	754	754		735	647	384	384	634	80	285	
20 (500) AS4087 PN35, SO / RF	8705 _ _ _ 200CY	839		834	836	837		735	647	384	384	597	80	487	

Table 43: 8705-M Flanged sensor DN 600mm to 900mm slip-on flanges—low pressure (P ≤ Class 300)—Millimeters

SIZE, DESCRIPTION	MODEL NUMBER 	OVERALL LENGTH							FLANGE Ø DIM "B"	BODY Ø DIM "C"	DIM "D" CL to TA		LINER Ø ON FACE DIM "J"	LIFT RING HEIGHT DIM "K"	FLOW TUBE WEIGHT (kg)
		DIM "A" PTFE	DIM "A" ETFE	DIM "A" NEOPRENE	DIM "A" LINATEX	DIM "A" POLY	DIM "A" PFA	STYLE A			STYLE B				
		24 (600) ASME - 150 , SO / RF	8705 _ _ _ 240C1	908		903	905	906				813			
24 (600) ASME - 300 , SO / RF	8705 _ _ _ 240C3	1000		995	997	998		914	763	442	441	692	80	784	
24 (600) ASME - 600 DERAT., SO / RF	8705 _ _ _ 240C6	1050						940	763	442	441	692	80	1220	
24 (600) DIN - PN10, SO / RF	8705 _ _ _ 240CD	908		903	905	906		780	763	442	441	685	80	300	
24 (600) DIN - PN16, SO / RF	8705 _ _ _ 240CE	908		903	905	906		840	763	442	441	725	80	377	
24 (600) DIN - PN25, SO / RF	8705 _ _ _ 240CF	1000		995	997	998		845	763	442	441	720	80	613	
24 (600) DIN - PN40, SO / RF	8705 _ _ _ 240CH	1000		995	997	998		890	763	442	441	735	80	738	
24 (600) AS2129 TABLE D, SO / RF	8705 _ _ _ 240CK	908		903	905	906		825	763	442	441	720	80	314.2	
24 (600) AS2129 TABLE E, SO / RF	8705 _ _ _ 240CL	908		903	905	906		825	763	442	441	717	80	369.6	
24 (600) JIS B2200 - 10K, SO / RF	8705 _ _ _ 240CP	908		903	905	906		795	763	442	441	690	80	299.1	
24 (600) JIS B2200 - 20K, SO / RF	8705 _ _ _ 240CR	1000		995	997	998		845	763	442	441	720	80	613.9	
24 (600) AS4087 PN16, SO / RF	8705 _ _ _ 240CU	908		903	905	906		825	763	442	441	720	80	321.6	
24 (600) AS4087 PN21, SO / RF	8705 _ _ _ 240CW	1000		995	997	998		850	763	442	441	739	80	586.5	
24 (600) AS4087 PN35, SO / RF	8705 _ _ _ 240CY	1000		995	997	998		850	763	442	441	699	80	693.2	
30 (750) AWWA CLASS D, SO / FF	8705 _ _ _ 300C1	940		935	937	941		984	902	511	511	857	80	407.0	
30 (750) MSS SP44 - 150 , SO / RF	8705 _ _ _ 300C2	1056		1050	1053	1053		984	902	511	511	857	80	708.3	
30 (750) MSS SP44 - 300 , SO / RF	8705 _ _ _ 300C3	1200		1195	1197	1198		1092	902	511	511	857	80	1338.4	
30 (750) AS2129 TABLE D, SO / RF	8705 _ _ _ 300CK	940		935	937	941		995	902	511	511	888	80	470.4	
30 (750) AS2129 TABLE E, SO / RF	8705 _ _ _ 300CL	1056		1050	1053	1053		995	902	511	511	857	80	578.4	
30 (750) AS4087 PN16, SO / RF	8705 _ _ _ 300CU	940		935	937	938		995	902	511	511	888	80	491.5	
30 (750) AS4087 PN21, SO / RF	8705 _ _ _ 300CW	1056		1050	1053	1053		1015	902	511	511	76	80	485.8	
30 (750) AS4087 PN35, SO / RF	8705 _ _ _ 300CY	1200		1195	1197	1198		1015	902	511	511	898	80	1112.4	
36 (900) AWWA CLASS D, SO / FF	8705 _ _ _ 360C1	1032		1027	1029	1033		1168	1102	610	611	1022	80	574.9	
36 (900) MSS SP44 - 150 , SO / RF	8705 _ _ _ 360C2	1200		1195	1197	1198		1168	1102	610	611	1022	80	1156.9	
36 (900) MSS SP44 - 300 , SO / RF	8705 _ _ _ 360C3	1351		1345	1348	1348		1270	1102	610	611	1022	86	2079.3	
36 (900) AS2129 TABLE D, SO / RF	8705 _ _ _ 360CK	1032		1027	1029	1033		1175	1102	610	611	1050	80	687.3	
36 (900) AS2129 TABLE E, SO / RF	8705 _ _ _ 360CL	1200		1195	1197	1198		1175	1102	610	611	1050	80	955.1	
36 (900) AS4087 PN16, SO / RF	8705 _ _ _ 360CU	1032		1027	1029	1030		1175	1102	610	611	1050	80	707.3	
36 (900) AS4087 PN21, SO / RF	8705 _ _ _ 360CW	1200		1195	1197	1198		1185	1102	610	611	1060	80	934.8	
36 (900) AS4087 PN35, SO / RF	8705 _ _ _ 360CY	1351		1345	1348	1348		1185	1102	610	611	1030	86	1678.7	

Figure 16: 8705-M Flanged sensor 1/2 -in. to 36-in. (DN 15mm to 900mm) weld neck flanges—(P ≤ Class 600 derated)

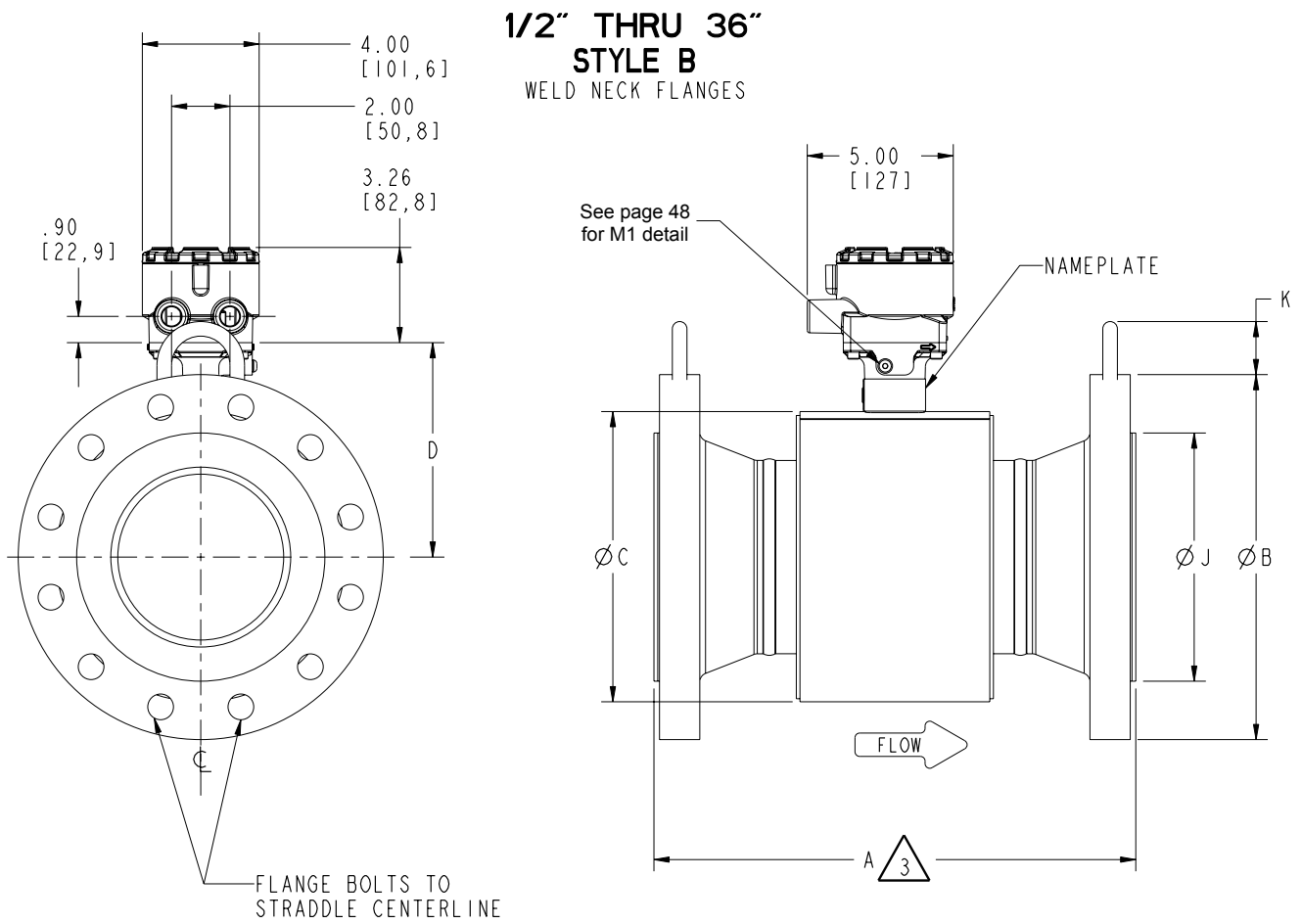

Table 44: 8705-M Flanged sensor 1/2-in. to 36-in. weld neck flanges—low pressure (P ≤ Class 600 derated)—Inches

SIZE, DESCRIPTION	MODEL NUMBER 	OVERALL LENGTH				FLANGE Ø DIM "B"	BODY Ø DIM "C"	DIN "D" CL 10 TA		LINER Ø ON FACE DIM "J"	LIFT RING HEIGHT DIM "K"	FLOW TUBE WEIGHT (lbs.)
		DIM "A" PTFE	DIM "A" NEOPRENE	DIM "A" LINATEX	DIM "A" POLY			STYLE A	STYLE B			
0.5 (15) ASME - 150 , WN / RF	8705 _ _ _ 005D1	10.32				3.50	4.50	4.41	4.61	1.38		10
0.5 (15) ASME - 300 , WN / RF	8705 _ _ _ 005D3	10.34				3.75	4.50	4.41	4.61	1.38		11
1 (25) ASME - 150 , WN / RF	8705 _ _ _ 010D1	11.17	11.08	11.14	11.17	4.25	4.50	4.41	4.61	2.00		13
1 (25) ASME - 300 , WN / RF	8705 _ _ _ 010D3	11.17	11.08	11.14	11.17	4.88	4.50	4.41	4.61	2.00		16
1 (25) ASME - 600 DERAT., WN / RF	8705 _ _ _ 010D6	11.68				4.88	4.50	4.41	4.61	2.00		17
1.5 (40) ASME - 150 , WN / RF	8705 _ _ _ 015D1	11.08	11.01	11.07	11.08	5.00	5.21	4.82	4.97	2.88		19
1.5 (40) ASME - 300 , WN / RF	8705 _ _ _ 015D3	11.08	11.01	11.07	11.08	6.12	5.21	4.82	4.97	2.88		24
1.5 (40) ASME - 600 DERAT., WN / RF	8705 _ _ _ 015D6	11.76				6.12	5.21	4.82	4.97	2.50		26
2 (50) ASME - 150 , WN / RF	8705 _ _ _ 020D1	11.20	11.13	11.19	11.20	6.00	5.21	4.82	4.97	3.62		24
2 (50) ASME - 300 , WN / RF	8705 _ _ _ 020D3	11.20	11.13	11.19	11.20	6.50	5.21	4.82	4.97	3.62		28
2 (50) ASME - 600 DERAT., WN / RF	8705 _ _ _ 020D6	12.04				6.50	5.21	4.82	4.97	3.25		32
3 (80) ASME - 150 , WN / RF	8705 _ _ _ 030D1	12.17	12.06	12.12	12.18	7.50	7.21	5.82	5.97	5.00	1.70	43
3 (80) ASME - 300 , WN / RF	8705 _ _ _ 030D3	12.17	12.06	12.12	12.18	8.25	7.21	5.82	5.97	5.00	1.70	53
3 (80) ASME - 600 DERAT., WN / RF	8705 _ _ _ 030D6	13.03				8.25	7.21	5.82	5.97	4.63	1.70	59
4 (100) ASME - 150 , WN / RF	8705 _ _ _ 040D1	13.94	13.81	13.87	13.96	9.00	7.91	6.17	6.32	6.19	1.70	60
4 (100) ASME - 300 , WN / RF	8705 _ _ _ 040D3	13.94	13.81	13.87	13.96	10.00	7.91	6.17	6.32	6.19	1.70	81
4 (100) ASME - 600 DERAT., WN / RF	8705 _ _ _ 040D6	15.84				10.75	7.91	6.17	6.32	5.81	1.70	109
6 (150) ASME - 150 , WN / RF	8705 _ _ _ 060D1	16.66	16.48	16.54	16.60	11.00	9.98	7.30	7.35	8.50	1.70	100
6 (150) ASME - 300 , WN / RF	8705 _ _ _ 060D3	16.66	16.48	16.54	16.60	12.50	9.98	7.30	7.35	8.50	1.70	142
6 (150) ASME - 600 DERAT., WN / RF	8705 _ _ _ 060D6	19.05				14.00	9.98	7.30	7.35	8.00	1.70	231
8 (200) ASME - 150 , WN / RF	8705 _ _ _ 080D1	19.22	19.03	19.09	19.15	13.50	11.92	8.27	8.32	10.62	1.70	160
8 (200) ASME - 300 , WN / RF	8705 _ _ _ 080D3	19.22	19.03	19.09	19.15	15.00	11.92	8.27	8.32	10.62	1.70	220
8 (200) ASME - 600 DERAT., WN / RF	8705 _ _ _ 080D6	22.15				16.50	11.92	8.27	8.32	10.00	1.70	362
10 (250) ASME - 150 , WN / RF	8705 _ _ _ 100D1	19.95	19.68	19.74	19.80	16.00	14.64	9.69	9.68	12.75	2.00	230
10 (250) ASME - 300 , WN / RF	8705 _ _ _ 100D3	19.95	19.68	19.74	19.80	17.50	14.64	9.69	9.68	12.75	2.00	320
10 (250) ASME - 600 DERAT., WN / RF	8705 _ _ _ 100D6	23.68				20.00	14.64	9.69	9.68	12.00	2.00	583
12 (300) ASME - 150 , WN / RF	8705 _ _ _ 120D1	23.83	23.49	23.55	23.61	19.00	16.50	10.77	10.61	15.00	2.00	349
12 (300) ASME - 300 , WN / RF	8705 _ _ _ 120D3	23.83	23.49	23.55	23.61	20.50	16.50	10.77	10.61	15.00	2.00	464
12 (300) ASME - 600 DERAT., WN / RF	8705 _ _ _ 120D6	26.93				22.00	16.50	10.77	10.61	14.00	2.00	758
14 (350) ASME - 150 , WN / RF	8705 _ _ _ 140D1	27.20	27.00	27.06	27.12	21.00	18.92	11.83	11.82	16.25	2.00	452
14 (350) ASME - 300 , WN / RF	8705 _ _ _ 140D3	27.20	27.00	27.06	27.12	23.00	18.92	11.83	11.82	16.25	2.00	661
14 (350) ASME - 600 DERAT., WN / RF	8705 _ _ _ 140D6	30.29				23.75	18.92	11.83	11.82	15.25	2.00	938
16 (400) ASME - 150 , WN / RF	8705 _ _ _ 160D1	29.78	29.58	29.64	29.70	23.50	20.94	12.84	12.83	18.50	3.13	487
16 (400) ASME - 300 , WN / RF	8705 _ _ _ 160D3	29.78	29.58	29.64	29.70	25.50	20.94	12.84	12.83	18.50	3.13	853
16 (400) ASME - 600 DERAT., WN / RF	8705 _ _ _ 160D6	33.57				27.00	20.94	12.84	12.83	17.50	3.13	1274
18 (450) ASME - 150 , WN / RF	8705 _ _ _ 180D1	31.97	31.77	31.83	31.89	25.00	23.46	14.10	14.09	21.00	3.13	679
18 (450) ASME - 300 , WN / RF	8705 _ _ _ 180D3	31.97	31.77	31.83	31.89	28.00	23.46	14.10	14.09	21.00	3.13	1094
18 (450) ASME - 600 DERAT., WN / RF	8705 _ _ _ 180D6	35.23				29.25	23.46	14.10	14.09	20.00	3.13	1531
20 (500) ASME - 150 , WN / RF	8705 _ _ _ 200D1	34.76	34.56	34.62	34.68	27.50	25.48	15.11	15.10	23.00	3.13	722
20 (500) ASME - 300 , WN / RF	8705 _ _ _ 200D3	34.76	34.56	34.62	34.68	30.50	25.48	15.11	15.10	23.00	3.13	1337
20 (500) ASME - 600 DERAT., WN / RF	8705 _ _ _ 200D6	38.26				32.00	25.48	15.11	15.10	22.00	3.13	1892
24 (600) ASME - 150 , WN / RF	8705 _ _ _ 240D1	38.30	38.10	38.16	38.22	32.00	30.03	17.39	17.38	27.25	3.13	1118
24 (600) ASME - 300 , WN / RF	8705 _ _ _ 240D3	38.30	38.10	38.16	38.22	36.00	30.03	17.39	17.38	27.25	3.13	1964
24 (600) ASME - 600 DERAT., WN / RF	8705 _ _ _ 240D6	42.33				37.00	30.03	17.39	17.38	26.00	3.13	2838
30 (750) ASME - 150 , WN / RF	8705 _ _ _ 300D2	41.56	41.36	41.45	41.48	38.75	35.50	20.13	20.11	33.75	3.13	1679
30 (750) ASME - 300 , WN / RF	8705 _ _ _ 300D3	47.16	46.96	47.02	47.08	43.00	35.50	20.13	20.11	33.75	3.13	3166
36 (900) ASME - 150 , WN / RF	8705 _ _ _ 360D2	47.25	47.05	47.14	47.17	46.00	43.37	24.00	24.05	40.25	3.13	2728
36 (900) ASME - 300 , WN / RF	8705 _ _ _ 360D3	53.16	52.96	53.02	53.08	50.00	43.37	24.00	24.05	40.25	3.38	4723

Table 45: 8705-M Flanged sensor DN 15mm to 900mm weld neck flanges—low pressure (P ≤ Class 600 derated)—Millimeters

SIZE, DESCRIPTION	MODEL NUMBER 	OVERALL LENGTH				FLANGE Ø DIM "B"	BODY Ø DIM "C"	DIM "D" CL to TA		LINER Ø ON FACE DIM "J"	LIFT RING HEIGHT DIM "K"	FLOW TUBE WEIGHT (kg)
		DIM "A" PTFE	DIM "A" NEOPRENE	DIM "A" LINATEX	DIM "A" POLY			STYLE A	STYLE B			
0.5 (15) ASME - 150 , WN / RF	8705 _ _ _ 005D1	262				88	114	112	117	35		4
0.5 (15) ASME - 300 , WN / RF	8705 _ _ _ 005D3	263				95	114	112	117	35		5
1 (25) ASME - 150 , WN / RF	8705 _ _ _ 010D1	284	281	283	284	108	114	112	117	51		6
1 (25) ASME - 300 , WN / RF	8705 _ _ _ 010D3	284	281	283	284	124	114	112	117	51		7
1 (25) ASME - 600 DERAT., WN / RF	8705 _ _ _ 010D6	297				124	114	112	117	51		8
1.5 (40) ASME - 150 , WN / RF	8705 _ _ _ 015D1	281	280	281	281	127	132	122	126	73		8
1.5 (40) ASME - 300 , WN / RF	8705 _ _ _ 015D3	281	280	281	281	155	132	122	126	73		11
1.5 (40) ASME - 600 DERAT., WN / RF	8705 _ _ _ 015D6	299				155	132	122	126	64		12
2 (50) ASME - 150 , WN / RF	8705 _ _ _ 020D1	285	283	284	284	152	132	122	126	92		11
2 (50) ASME - 300 , WN / RF	8705 _ _ _ 020D3	285	283	284	284	165	132	122	126	92		13
2 (50) ASME - 600 DERAT., WN / RF	8705 _ _ _ 020D6	306				165	132	122	126	83		14
3 (80) ASME - 150 , WN / RF	8705 _ _ _ 030D1	309	306	308	309	191	183	148	152	127	43	20
3 (80) ASME - 300 , WN / RF	8705 _ _ _ 030D3	309	306	308	309	210	183	148	152	127	43	24
3 (80) ASME - 600 DERAT., WN / RF	8705 _ _ _ 030D6	331				210	183	148	152	117	43	27
4 (100) ASME - 150 , WN / RF	8705 _ _ _ 040D1	354	351	352	355	229	201	157	160	157	43	27
4 (100) ASME - 300 , WN / RF	8705 _ _ _ 040D3	354	351	352	355	254	201	157	160	157	43	37
4 (100) ASME - 600 DERAT., WN / RF	8705 _ _ _ 040D6	402				273	201	157	160	148	43	49
6 (150) ASME - 150 , WN / RF	8705 _ _ _ 060D1	423	419	420	422	279	253	185	187	216	43	45
6 (150) ASME - 300 , WN / RF	8705 _ _ _ 060D3	423	419	420	422	318	253	185	187	216	43	64
6 (150) ASME - 600 DERAT., WN / RF	8705 _ _ _ 060D6	484				356	253	185	187	203	43	105
8 (200) ASME - 150 , WN / RF	8705 _ _ _ 080D1	488	483	485	486	343	303	210	211	270	43	73
8 (200) ASME - 300 , WN / RF	8705 _ _ _ 080D3	488	483	485	486	381	303	210	211	270	43	100
8 (200) ASME - 600 DERAT., WN / RF	8705 _ _ _ 080D6	563				419	303	210	211	254	43	164
10 (250) ASME - 150 , WN / RF	8705 _ _ _ 100D1	507	500	501	503	406	372	246	246	324	51	104
10 (250) ASME - 300 , WN / RF	8705 _ _ _ 100D3	507	500	501	503	445	372	246	246	324	51	145
10 (250) ASME - 600 DERAT., WN / RF	8705 _ _ _ 100D6	601				508	372	246	246	305	51	265
12 (300) ASME - 150 , WN / RF	8705 _ _ _ 120D1	605	597	598	600	483	419	274	269	381	51	158
12 (300) ASME - 300 , WN / RF	8705 _ _ _ 120D3	605	597	598	600	521	419	274	269	381	51	211
12 (300) ASME - 600 DERAT., WN / RF	8705 _ _ _ 120D6	684				559	419	274	269	356	51	344
14 (350) ASME - 150 , WN / RF	8705 _ _ _ 140D1	691	686	687	689	533	481	300	300	413	51	205
14 (350) ASME - 300 , WN / RF	8705 _ _ _ 140D3	691	686	687	689	584	481	300	300	413	51	300
14 (350) ASME - 600 DERAT., WN / RF	8705 _ _ _ 140D6	769				603	481	300	300	387	51	426
16 (400) ASME - 150 , WN / RF	8705 _ _ _ 160D1	757	751	753	754	597	532	326	326	470	80	221
16 (400) ASME - 300 , WN / RF	8705 _ _ _ 160D3	757	751	753	754	648	532	326	326	470	80	387
16 (400) ASME - 600 DERAT., WN / RF	8705 _ _ _ 160D6	853				686	532	326	326	445	80	578
18 (450) ASME - 150 , WN / RF	8705 _ _ _ 180D1	812	807	808	810	635	596	358	358	533	80	308
18 (450) ASME - 300 , WN / RF	8705 _ _ _ 180D3	812	807	808	810	711	596	358	358	533	80	496
18 (450) ASME - 600 DERAT., WN / RF	8705 _ _ _ 180D6	895				743	596	358	358	508	80	694
20 (500) ASME - 150 , WN / RF	8705 _ _ _ 200D1	883	878	879	881	699	647	384	384	584	80	327
20 (500) ASME - 300 , WN / RF	8705 _ _ _ 200D3	883	878	879	881	775	647	384	384	584	80	606
20 (500) ASME - 600 DERAT., WN / RF	8705 _ _ _ 200D6	972				813	647	384	384	559	80	858
24 (600) ASME - 150 , WN / RF	8705 _ _ _ 240D1	973	968	969	971	813	763	442	441	692	80	507
24 (600) ASME - 300 , WN / RF	8705 _ _ _ 240D3	973	968	969	971	914	763	442	441	692	80	891
24 (600) ASME - 600 DERAT., WN / RF	8705 _ _ _ 240D6	1075				940	763	442	441	660	80	1287
30 (750) ASME - 150 , WN / RF	8705 _ _ _ 300D2	1056	1050	1053	1053	984	902	511	511	857	80	761
30 (750) ASME - 300 , WN / RF	8705 _ _ _ 300D3	1198	1193	1194	1196	1092	902	511	511	857	80	1436
36 (900) ASME - 150 , WN / RF	8705 _ _ _ 360D2	1200	1195	1197	1198	1168	1102	610	611	1022	80	1237
36 (900) ASME - 300 , WN / RF	8705 _ _ _ 360D3	1350	1345	1347	1348	1270	1102	610	611	1022	86	2143

Figure 17: 8705-M Flanged sensor 1/2 -in. to 36-in. (DN 15mm to 900mm) M2/M4 coil housing (P ≤ Class 600 derated)

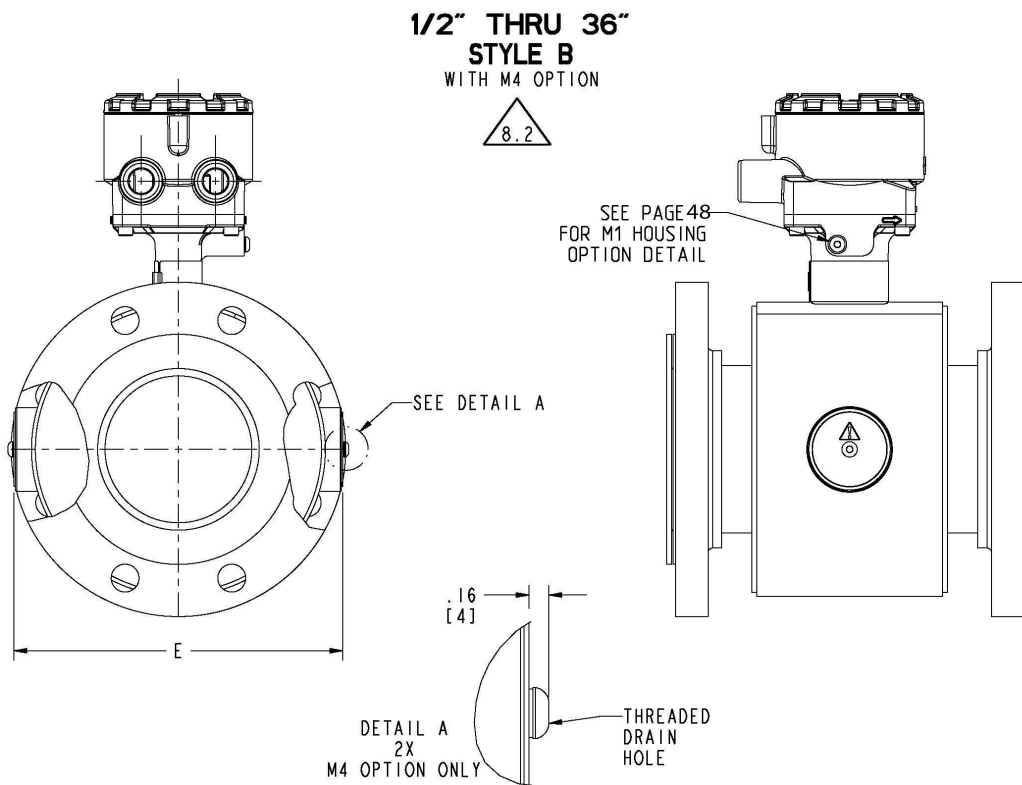
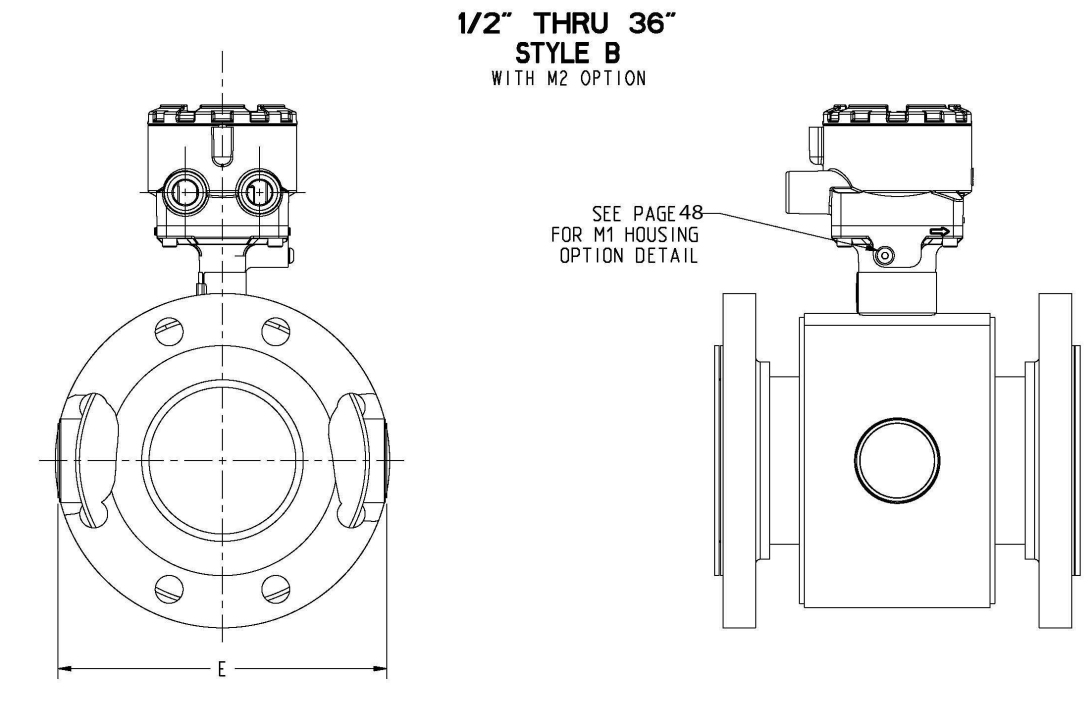



Figure 18: 8705-M Flanged Sensor 1/2 -in. to 36-in. (DN 15mm to 900mm) M2/M4 coil housing (P ≤ Class 600 derated)

BODY WIDTH WITH ELECTRODE ACCESS (M2)		
Size -- in (mm) All Flanges	Body Width w/ M2 DIM "E" (inch)	Body Width w/ M2 DIM "E" (mm)
0.5 (15)	5.22	133
1 (25)	5.70	145
1.5 (40)	5.88	149
2 (50)	6.36	161
2.5 (60)	6.86	174
3 (80)	7.88	200
4 (100)	8.88	226
5 (125)	9.71	247
6 (150)	10.62	270
8 (200)	12.62	321
10 (250)	15.53	394
12 (300)	17.53	445
14 (350)	20.68	525
16 (400)	22.68	576
18 (450)	24.68	627
20 (500)	26.68	678
24 (600)	30.68	779
30 (750)	36.68	932
36 (900)	44.18	1122

 WHEN VENTING THE ELECTRODE COMPARTMENT, THE VENT AND RECOVERY PIPING DIAMETER MUST NOT BE SMALLER THAN THE M6 COVER THREADING TO AVOID BUILDING PRESSURE INSIDE THE ELECTRODE COMPARTMENT.

 WHEN M4 OPTION IS SELECTED ADD .320" (8mm) TO M2 DIM 'E' (BODY WIDTH DIMENSION)

8705-M High pressure dimensions

The following notes apply to [Figure 19](#) and [Table 46](#) through [Table 51](#):

 FOR BREVITY, THE MODEL NUMBER LIST ONLY CONTAINS THE CODES FOR CARBON STEEL FLANGES. 304 AND 316 STAINLESS STEEL FLANGES ARE DIMENSIONALLY IDENTICAL TO CARBON STEEL. USE THE TABLE BELOW TO FIND THE CARBON STEEL CODE THAT CORRESPONDS TO EACH STAINLESS STEEL CODE.

 OPTIONAL RELIEF VALVE ASSEMBLY IS 1.75" 144,51

STAINLESS STEEL CODES	ARE THE SAME DIMENSIONS AS CARBON STEEL CODE
S, P	C
T, R	D
G, H	F
K, L	J

Figure 19: 8705-M Flanged Sensor 1/2-in. to 24-in. (DN 15mm to 600mm) slip-on flange - high pressure (P ≤ Class 900)

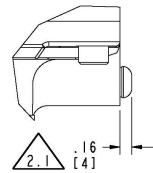
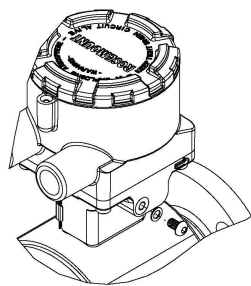
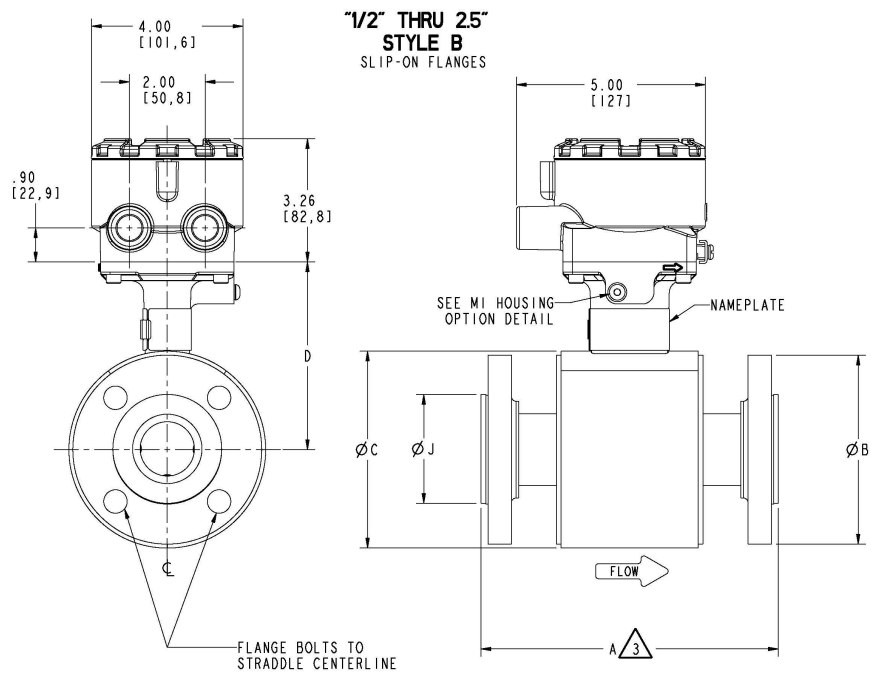

M1 HOUSING
OPTION
DETAIL

Table 46: 8705-M Flanged Sensor 1/2-in. to 24-in. slip-on flange—high pressure (P ≤ Class 900)—Inches

SIZE, DESCRIPTION	MODEL NUMBER 	OVERALL LENGTH					FLANGE Ø DIM "B"	BODY Ø DIM "C"	DIM "D" CL TO TA		LINER Ø ON FACE DIM "J"	LIFT RING HEIGHT DIM "K"	FLOW TUBE WEIGHT (lbs.)
		DIM "A" PTFE	DIM "A" ETFE	DIM "A" NEOPRENE	DIM "A" LINATEX	DIM "A" POLY			STYLE A	STYLE B			
0.5 (15) ASME - 600 DERAT., SO / RF	8705 _ _ _ 005C6	8.38	8.38	8.38	8.48	8.38	3.75	4.50	4.41	4.61	1.38		10
0.5 (15) ASME - 600 FULL, SO / RF	8705 _ _ _ 005C7		8.38	8.25	8.25	8.25	3.75	4.50	4.41	4.61	1.38		10
1 (25) ASME - 900 , SO / RTJ	8705 _ _ _ 010.9			9.53	9.53	9.53	5.88	4.50	4.41	4.61	1.51	1.70	24
1 (25) ASME - 600 FULL, SO / RF	8705 _ _ _ 010C7			8.53	8.53	8.53	4.88	4.50	4.41	4.61	1.63		15
1 (25) ASME - 900 , SO / RF	8705 _ _ _ 010C9			9.49	9.49	9.49	5.88	4.50	4.41	4.61	1.63	1.70	24
1.5 (40) ASME - 600 FULL, SO / RF	8705 _ _ _ 015C7			8.42	8.42	8.42	6.12	5.21	4.82	4.97	2.50		23
1.5 (40) ASME - 900 , SO / RF	8705 _ _ _ 015C9			9.49	9.49	9.49	7.00	5.21	4.82	4.97	2.50	1.70	34
2 (50) ASME - 600 FULL, SO / RF	8705 _ _ _ 020C7			8.57	8.57	8.57	6.50	5.21	4.82	4.97	3.25		27
2 (50) ASME - 900 , SO / RF	8705 _ _ _ 020C9			10.23	10.23	10.23	8.50	5.21	4.82	4.97	3.25	1.70	57
2.5 (65) ASME - 600 FULL, SO / RF	8705 _ _ _ 025C7			8.61			7.50	6.31	5.37	5.52	3.75		41
2.5 (65) ASME - 900 , SO / RF	8705 _ _ _ 025C9			10.23			9.62	6.31	5.37	5.52	3.75	1.70	82
3 (65) ASME - 600 FULL, SO / RTJ	8705 _ _ _ 030.7			12.19	12.19	12.19	8.25	7.21	5.82	5.97	4.00		53
3 (65) ASME - 900 , SO / RTJ	8705 _ _ _ 030.9			12.82	12.82	12.82	9.50	7.21	5.82	5.97	3.94		75
3 (80) ASME - 600 FULL, SO / RF	8705 _ _ _ 030C7			12.16	12.16	12.16	8.25	7.21	5.82	5.97	4.63	1.70	53
3 (80) ASME - 900 , SO / RF	8705 _ _ _ 030C9			12.79	12.79	12.79	9.50	7.21	5.82	5.97	4.63	1.70	74
4 (80) ASME - 600 FULL, SO / RTJ	8705 _ _ _ 040.7			12.60	12.60	12.60	10.75	7.91	6.17	6.32	4.94	1.70	92
4 (80) ASME - 900 , SO / RTJ	8705 _ _ _ 040.9			13.89	13.89	13.89	11.50	7.91	6.17	6.32	4.94	2.00	123
4 (100) ASME - 600 FULL, SO / RF	8705 _ _ _ 040C7			12.56	12.56	12.56	10.75	7.91	6.17	6.32	5.81	1.70	93
4 (100) ASME - 900 , SO / RF	8705 _ _ _ 040C9			13.86	13.86	13.86	11.50	7.91	6.17	6.32	5.81	2.00	123
5 (125) ASME - 600 FULL, SO / RF	8705 _ _ _ 050C7			12.81			13.00	9.61	7.02	7.17	6.91	1.70	156
5 (125) ASME - 900 , SO / RF	8705 _ _ _ 050C9			13.86			13.75	9.61	7.02	7.17	6.91	1.70	201
6 (125) ASME - 600 FULL, SO / RTJ	8705 _ _ _ 060.7			15.57	15.57	15.57	14.00	9.98	7.30	7.35	7.12	1.70	193
6 (200) ASME - 900 , SO / RTJ	8705 _ _ _ 060.9			17.58	17.58	17.58	15.00	9.98	7.30	7.35	7.12	2.00	254
6 (150) ASME - 600 FULL, SO / RF	8705 _ _ _ 060C7			13.92	13.92	13.92	14.00	9.98	7.30	7.35	8.00	1.70	189
6 (150) ASME - 900 , SO / RF	8705 _ _ _ 060C9			17.55	17.55	17.55	15.00	9.98	7.30	7.35	8.00	2.00	254
8 (150) ASME - 600 FULL, SO / RTJ	8705 _ _ _ 080.7			17.58	17.58	17.58	16.50	11.92	8.27	8.32	9.37	1.70	298
8 (150) ASME - 900 , SO / RTJ	8705 _ _ _ 080.9			20.61	20.61	20.61	18.50	11.92	8.27	8.32	9.13	3.13	446
8 (200) ASME - 600 FULL, SO / RF	8705 _ _ _ 080C7			16.44	16.44	16.44	16.50	11.92	8.27	8.32	10.00	1.70	292
8 (200) ASME - 900 , SO / RF	8705 _ _ _ 080C9			20.58	20.58	20.58	18.50	11.92	8.27	8.32	10.00	3.13	444
10 (200) ASME - 600 FULL, SO / RTJ	8705 _ _ _ 100.7			19.08	19.08	19.08	20.00	14.64	9.69	9.68	11.50	2.00	480
10 (200) ASME - 900 , SO / RTJ	8705 _ _ _ 100.9			21.57	21.57	21.57	21.50	14.64	9.69	9.68	11.25	3.13	655
10 (250) ASME - 600 FULL, SO / RF	8705 _ _ _ 100C7			19.05	19.05	19.05	20.00	14.64	9.69	9.68	12.00	2.00	476
10 (250) ASME - 900 , SO / RF	8705 _ _ _ 100C9			21.54	21.54	21.54	21.50	14.64	9.69	9.68	12.00	3.13	650
12 (250) ASME - 600 FULL, SO / RTJ	8705 _ _ _ 120.7			21.78	21.78	21.78	22.00	16.80	10.77	10.76	13.75	2.00	636
12 (250) ASME - 900 , SO / RTJ	8705 _ _ _ 120.9			25.18	25.18	25.18	24.00	16.80	10.77	10.76	13.50	3.13	914
12 (300) ASME - 600 FULL, SO / RF	8705 _ _ _ 120C7			21.75	21.75	21.75	22.00	16.80	10.77	10.76	14.00	2.00	620
12 (300) ASME - 900 , SO / RF	8705 _ _ _ 120C9			25.15	25.15	25.15	24.00	16.80	10.77	10.76	14.00	3.13	907
14 (300) ASME - 600 FULL, SO / RTJ	8705 _ _ _ 140.7			25.44	25.44	25.44	23.75	18.92	11.83	11.82	15.00	2.00	780
14 (350) ASME - 600 FULL, SO / RF	8705 _ _ _ 140C7			25.41	25.41	25.41	23.75	18.92	11.83	11.82	15.25	2.00	771
16 (350) ASME - 600 FULL, SO / RTJ	8705 _ _ _ 160.7			28.94	28.94	28.94	27.00	20.94	12.84	12.83	17.00	3.13	1108
16 (400) ASME - 600 FULL, SO / RF	8705 _ _ _ 160C7			28.91	28.91	28.91	27.00	20.94	12.84	12.83	17.50	3.13	1100
18 (400) ASME - 600 FULL, SO / RTJ	8705 _ _ _ 180.7			32.42	32.42	32.42	29.25	23.46	14.10	14.09	19.38	3.13	1415
18 (450) ASME - 600 FULL, SO / RF	8705 _ _ _ 180C7			32.39	32.39	32.39	29.25	23.46	14.10	14.09	20.00	3.13	1405
20 (450) ASME - 600 FULL, SO / RTJ	8705 _ _ _ 200.7			36.55	36.55	36.55	32.00	25.48	15.11	15.10	21.00	3.13	1839
20 (500) ASME - 600 FULL, SO / RF	8705 _ _ _ 200C7			36.52	36.52	36.52	32.00	25.48	15.11	15.10	22.00	3.13	1822
24 (500) ASME - 600 FULL, SO / RTJ	8705 _ _ _ 240.7			41.05	41.05	41.05	37.00	30.03	17.39	17.38	25.00	3.13	2724
24 (600) ASME - 600 FULL, SO / RF	8705 _ _ _ 240C7			41.02	41.02	41.02	37.00	30.03	17.39	17.38	26.00	3.13	2692

Table 47: 8705-M Flanged Sensor DN 15mm to 600mm slip-on flange—high pressure (P ≤ Class 900)—Millimeters

SIZE, DESCRIPTION	MODEL NUMBER 	OVERALL LENGTH					FLANGE Ø DIM "B"	BODY Ø DIM "C"	DIM "D" CL to TA		LINER Ø ON FACE DIM "J"	LIFT RING HEIGHT DIM "K"	FLOW TUBE WEIGHT (kg)
		DIM "A" PTFE	DIM "A" ETFE	DIM "A" NEOPRENE	DIM "A" LINATEX	DIM "A" POLY			STYLE A	STYLE B			
0.5 (15) ASME - 600 DERAT., SO / RF	8705 _ _ _ 005C6	213	213	213	215	213	95	114	112	117	35		5
0.5 (15) ASME - 600 FULL, SO / RF	8705 _ _ _ 005C7		213	209	209	209	95	114	112	117	35		5
1 (25) ASME - 900 , SO / RTJ	8705 _ _ _ 010_9			242	242	242	149	114	112	117	38	43	11
1 (25) ASME - 600 FULL, SO / RF	8705 _ _ _ 010C7			217	217	217	124	114	112	117	41		7
1 (25) ASME - 900 , SO / RF	8705 _ _ _ 010C9			241	241	241	149	114	112	117	41	43	11
1.5 (40) ASME - 600 FULL, SO / RF	8705 _ _ _ 015C7			214	214	214	155	132	122	126	64		11
1.5 (40) ASME - 900 , SO / RF	8705 _ _ _ 015C9			241	241	241	178	132	122	126	64	43	16
2 (50) ASME - 600 FULL, SO / RF	8705 _ _ _ 020C7			218	218	218	165	132	122	126	83		12
2 (50) ASME - 900 , SO / RF	8705 _ _ _ 020C9			260	260	260	216	132	122	126	83	43	26
2.5 (65) ASME - 600 FULL, SO / RF	8705 _ _ _ 025C7			219			191	160	136	140	95		19
2.5 (65) ASME - 900 , SO / RF	8705 _ _ _ 025C9			260			244	160	136	140	95	43	37
3 (65) ASME - 600 FULL, SO / RTJ	8705 _ _ _ 030_7			310	310	310	210	183	148	152	102		24
3 (65) ASME - 900 , SO / RTJ	8705 _ _ _ 030_9			326	326	326	241	183	148	152	100		34
3 (80) ASME - 600 FULL, SO / RF	8705 _ _ _ 030C7			309	309	309	210	183	148	152	118	43	24
3 (80) ASME - 900 , SO / RF	8705 _ _ _ 030C9			325	325	325	241	183	148	152	118	43	34
4 (80) ASME - 600 FULL, SO / RTJ	8705 _ _ _ 040_7			320	320	320	273	201	157	160	125	43	42
4 (80) ASME - 900 , SO / RTJ	8705 _ _ _ 040_9			353	353	353	292	201	157	160	125	51	56
4 (100) ASME - 600 FULL, SO / RF	8705 _ _ _ 040C7			319	319	319	273	201	157	160	148	43	42
4 (100) ASME - 900 , SO / RF	8705 _ _ _ 040C9			352	352	352	292	201	157	160	148	51	56
5 (125) ASME - 600 FULL, SO / RF	8705 _ _ _ 050C7			325			330	244	178	182	176	43	71
5 (125) ASME - 900 , SO / RF	8705 _ _ _ 050C9			352			349	244	178	182	176	43	91
6 (125) ASME - 600 FULL, SO / RTJ	8705 _ _ _ 060_7			396	396	396	356	253	185	187	181	43	87
6 (200) ASME - 900 , SO / RTJ	8705 _ _ _ 060_9			447	447	447	381	253	185	187	181	51	115
6 (150) ASME - 600 FULL, SO / RF	8705 _ _ _ 060C7			353	353	353	356	253	185	187	203	43	86
6 (150) ASME - 900 , SO / RF	8705 _ _ _ 060C9			446	446	446	381	253	185	187	203	51	115
8 (150) ASME - 600 FULL, SO / RTJ	8705 _ _ _ 080_7			447	447	447	419	303	210	211	238	43	135
8 (150) ASME - 900 , SO / RTJ	8705 _ _ _ 080_9			523	523	523	470	303	210	211	232	80	202
8 (200) ASME - 600 FULL, SO / RF	8705 _ _ _ 080C7			417	417	417	419	303	210	211	254	43	132
8 (200) ASME - 900 , SO / RF	8705 _ _ _ 080C9			523	523	523	470	303	210	211	254	80	202
10 (200) ASME - 600 FULL, SO / RTJ	8705 _ _ _ 100_7			485	485	485	508	372	246	246	292	51	218
10 (200) ASME - 900 , SO / RTJ	8705 _ _ _ 100_9			548	548	548	546	372	246	246	286	80	297
10 (250) ASME - 600 FULL, SO / RF	8705 _ _ _ 100C7			484	484	484	508	372	246	246	305	51	216
10 (250) ASME - 900 , SO / RF	8705 _ _ _ 100C9			547	547	547	546	372	246	246	305	80	295
12 (250) ASME - 600 FULL, SO / RTJ	8705 _ _ _ 120_7			553	553	553	559	427	274	273	349	51	288
12 (250) ASME - 900 , SO / RTJ	8705 _ _ _ 120_9			640	640	640	610	427	274	273	343	80	415
12 (300) ASME - 600 FULL, SO / RF	8705 _ _ _ 120C7			552	552	552	559	427	274	273	356	51	281
12 (300) ASME - 900 , SO / RF	8705 _ _ _ 120C9			639	639	639	610	427	274	273	356	80	412
14 (300) ASME - 600 FULL, SO / RTJ	8705 _ _ _ 140_7			646	646	646	603	481	300	300	381	51	354
14 (350) ASME - 600 FULL, SO / RF	8705 _ _ _ 140C7			645	645	645	603	481	300	300	387	51	350
16 (350) ASME - 600 FULL, SO / RTJ	8705 _ _ _ 160_7			735	735	735	686	532	326	326	432	80	503
16 (400) ASME - 600 FULL, SO / RF	8705 _ _ _ 160C7			734	734	734	686	532	326	326	445	80	499
18 (400) ASME - 600 FULL, SO / RTJ	8705 _ _ _ 180_7			823	823	823	743	596	358	358	492	80	642
18 (450) ASME - 600 FULL, SO / RF	8705 _ _ _ 180C7			823	823	823	743	596	358	358	508	80	637
20 (450) ASME - 600 FULL, SO / RTJ	8705 _ _ _ 200_7			928	928	928	813	647	384	384	533	80	834
20 (500) ASME - 600 FULL, SO / RF	8705 _ _ _ 200C7			928	928	928	813	647	384	384	559	80	826
24 (500) ASME - 600 FULL, SO / RTJ	8705 _ _ _ 240_7			1043	1043	1043	940	763	442	441	635	80	1236
24 (600) ASME - 600 FULL, SO / RF	8705 _ _ _ 240C7			1042	1042	1042	940	763	442	441	660	80	1221

Figure 20: 8705-M Flanged Sensor 1-in. to 24-in. (DN 25mm to 600mm) weld neck flange—(P ≤ Class 2500)

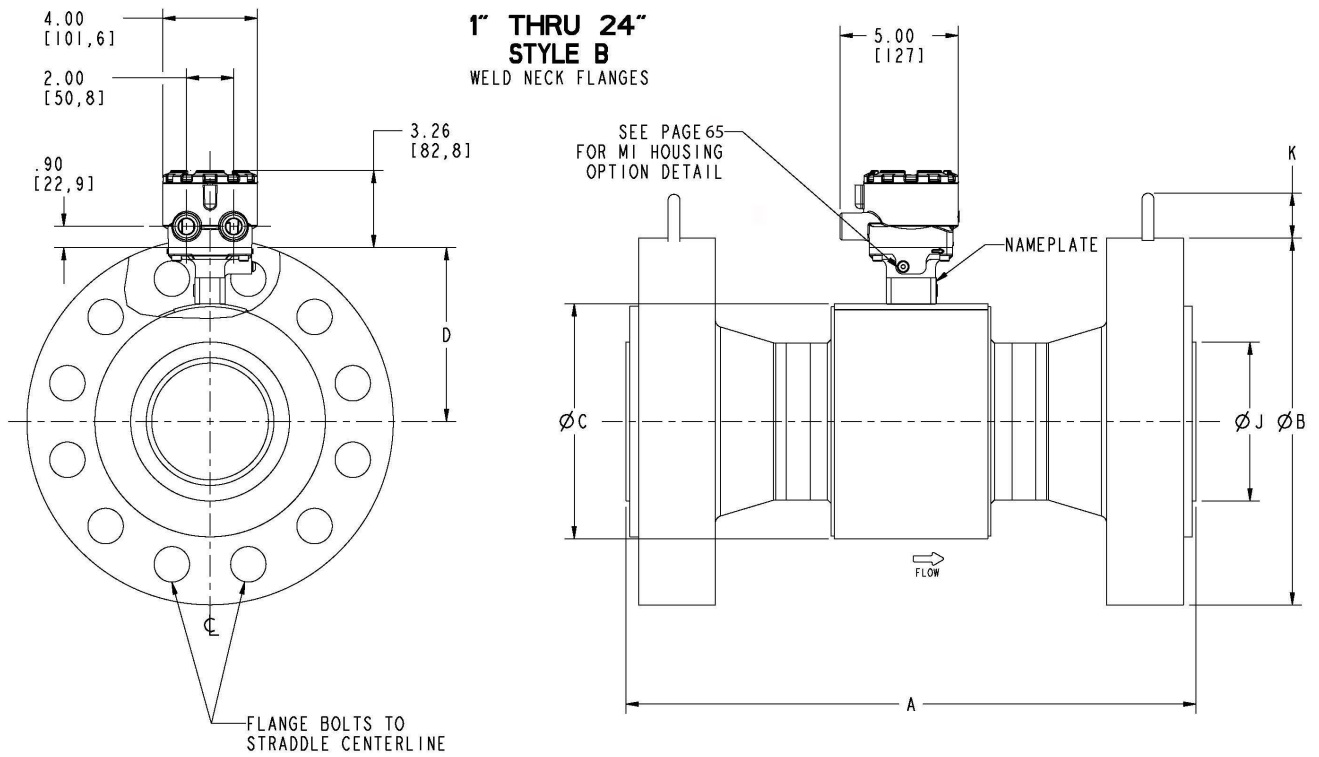

Table 48: 8705-M Flanged Sensor 1-in. to 5-in. weld neck flange—high pressure (P ≤ Class 2500)—Inches

SIZE, DESCRIPTION	MODEL NUMBER 				FLANGE Ø DIM "B"	BODY Ø DIM "C"	DIM "D" CL to TA		LINER Ø ON FACE DIM "J"	LIFT RING HEIGHT DIM "K"	FLOW TUBE WEIGHT (lbs.)
		DIM "A" NEOPRENE	DIM "A" LINATEX	DIM "A" POLY			STYLE A	STYLE B			
1 (25) ASME - 600 FULL, WN / RF	8705 _ _ _ 010D7	11.54	11.54	11.54	4.88	4.50	4.41	4.61	2.00		17
1 (25) ASME - 900 , WN / RF	8705 _ _ _ 010D9	12.51	12.51	12.51	5.88	4.50	4.41	4.61	2.00	1.70	25
1 (25) ASME -1500 , WN / RF	8705 _ _ _ 010DM	12.87	12.87	12.87	5.88	4.50	4.41	4.61	1.63	1.70	25
1 (25) ASME -2500 , WN / RF	8705 _ _ _ 010DN	14.29	14.29	14.29	6.25	4.50	4.41	4.61	1.63	1.70	34
1 (25) ASME - 600 FULL, WN / RTJ	8705 _ _ _ 010J7	11.57	11.57	11.57	4.88	4.50	4.41	4.61	1.31		17
1 (25) ASME - 900 , WN / RTJ	8705 _ _ _ 010J9	12.54	12.54	12.54	5.88	4.50	4.41	4.61	1.31	1.70	26
1 (25) ASME -1500 , WN / RTJ	8705 _ _ _ 010JM	12.90	12.90	12.90	5.88	4.50	4.41	4.61	1.26	1.70	26
1.5 (40) ASME - 600 FULL, WN / RF	8705 _ _ _ 015D7	11.56	11.56	11.56	6.12	5.21	4.82	4.97	2.50		26
1.5 (40) ASME - 900 , WN / RF	8705 _ _ _ 015D9	12.65	12.65	12.65	7.00	5.21	4.82	4.97	2.50	1.70	38
1.5 (40) ASME -1500 , WN / RF	8705 _ _ _ 015DM	13.09	13.09	13.09	7.00	5.21	4.82	4.97	2.50	1.70	39
1.5 (40) ASME -2500 , WN / RF	8705 _ _ _ 015DN	15.51	15.51	15.51	8.00	5.21	4.82	4.97	2.38	1.70	66
1.5 (40) ASME - 600 FULL, WN / RTJ	8705 _ _ _ 015J7	11.59	11.59	11.59	6.12	5.21	4.82	4.97	2.00		27
1.5 (40) ASME - 900 , WN / RTJ	8705 _ _ _ 015J9	12.68	12.68	12.68	7.00	5.21	4.82	4.97	2.00	1.70	38
1.5 (40) ASME -1500 , WN / RTJ	8705 _ _ _ 015JM	13.12	13.12	13.12	7.00	5.21	4.82	4.97	1.92	1.70	39
1.5 (40) ASME -2500 , WN / RTJ	8705 _ _ _ 015JN	15.66	15.66	15.66	8.00	5.21	4.82	4.97	1.84	1.70	68
2 (50) ASME - 600 FULL, WN / RF	8705 _ _ _ 020D7	11.83	11.83	11.83	6.50	5.21	4.82	4.97	3.25		32
2 (50) ASME - 900 , WN / RF	8705 _ _ _ 020D9	14.26	14.26	14.26	8.50	5.21	4.82	4.97	3.25	1.70	66
2 (50) ASME -1500 , WN / RF	8705 _ _ _ 020DM	14.82	14.82	14.82	8.50	5.21	4.82	4.97	3.25	1.70	69
2 (50) ASME -2500 , WN / RF	8705 _ _ _ 020DN	16.86	16.86	16.86	9.25	5.21	4.82	4.97	3.12	1.70	96
2 (50) ASME - 600 FULL, WN / RTJ	8705 _ _ _ 020J7	11.99	11.99	11.99	6.50	5.21	4.82	4.97	2.31		32
2 (50) ASME - 900 , WN / RTJ	8705 _ _ _ 020J9	14.42	14.42	14.42	8.50	5.21	4.82	4.97	2.62	1.70	67
2 (50) ASME -1500 , WN / RTJ	8705 _ _ _ 020JM	14.92	14.92	14.92	8.50	5.21	4.82	4.97	2.34	1.70	70
2 (50) ASME -2500 , WN / RTJ	8705 _ _ _ 020JN	17.01	17.01	17.01	9.25	5.21	4.82	4.97	2.59	1.70	98
2.5 (60) ASME -1500 , WN / RF	8705 _ _ _ 025DM	16.80	16.80	16.80	9.62	6.31	5.37	5.52	3.70	1.70	93
2.5 (60) ASME -2500 , WN / RF	8705 _ _ _ 025DN	19.70	19.70	19.70	10.50	6.31	5.37	5.52	3.50	1.70	136
2.5 (60) ASME -1500 , WN / RTJ	8705 _ _ _ 025JM	16.91	16.91	16.91	9.62	6.31	5.37	5.52	3.10	1.70	88
2.5 (60) ASME -2500 , WN / RTJ	8705 _ _ _ 025JN	19.94	19.94	19.94	10.50	6.31	5.37	5.52	2.80	1.70	132
3 (80) ASME - 600 FULL, WN / RF	8705 _ _ _ 030D7	12.78	12.78	12.78	8.25	7.21	5.82	5.97	4.63	1.70	59
3 (80) ASME - 900 , WN / RF	8705 _ _ _ 030D9	14.38	14.38	14.38	9.50	7.21	5.82	5.97	4.63	1.70	85
3 (80) ASME -1500 , WN / RF	8705 _ _ _ 030DM	16.27	16.27	16.27	10.50	7.21	5.82	5.97	4.33	1.70	125
3 (80) ASME -2500 , WN / RF	8705 _ _ _ 030DN	20.42	20.42	20.42	12.00	7.21	5.82	5.97	4.15	1.70	211
3 (80) ASME - 600 FULL, WN / RTJ	8705 _ _ _ 030J7	12.94	12.94	12.94	8.25	7.21	5.82	5.97	4.00	1.70	60
3 (80) ASME - 900 , WN / RTJ	8705 _ _ _ 030J9	14.54	14.54	14.54	9.50	7.21	5.82	5.97	3.94	1.70	86
3 (80) ASME -1500 , WN / RTJ	8705 _ _ _ 030JM	16.42	16.42	16.42	10.50	7.21	5.82	5.97	3.97	1.70	127
3 (80) ASME -2500 , WN / RTJ	8705 _ _ _ 030JN	20.70	20.70	20.70	12.00	7.21	5.82	5.97	3.41	1.70	214
4 (100) ASME - 600 FULL, WN / RF	8705 _ _ _ 040D7	15.57	15.57	15.57	10.75	7.91	6.17	6.32	5.81	1.70	108
4 (100) ASME - 900 , WN / RF	8705 _ _ _ 040D9	16.81	16.81	16.81	11.50	7.91	6.17	6.32	5.81	2.00	140
4 (100) ASME -1500 , WN / RF	8705 _ _ _ 040DM	18.18	18.18	18.18	12.25	7.91	6.17	6.32	5.71	2.00	188
4 (100) ASME -2500 , WN / RF	8705 _ _ _ 040DN	23.71	23.71	23.71	14.00	7.91	6.17	6.32	5.54	2.00	331
4 (100) ASME - 600 FULL, WN / RTJ	8705 _ _ _ 040J7	15.73	15.73	15.73	10.75	7.91	6.17	6.32	4.94	1.70	109
4 (100) ASME - 900 , WN / RTJ	8705 _ _ _ 040J9	16.97	16.97	16.97	11.50	7.91	6.17	6.32	4.94	2.00	141
4 (100) ASME -1500 , WN / RTJ	8705 _ _ _ 040JM	18.33	18.33	18.33	12.25	7.91	6.17	6.32	5.54	2.00	191
4 (100) ASME -2500 , WN / RTJ	8705 _ _ _ 040JN	24.12	24.12	24.12	14.00	7.91	6.17	6.32	4.38	2.00	337
5 (120) ASME -1500 , WN / RF	8705 _ _ _ 050DM	22.79	22.79	22.79	14.75	9.61	7.02	7.17	6.35	2.00	331
5 (120) ASME -2500 , WN / RF	8705 _ _ _ 050DN	28.45	28.45	28.45	16.50	9.61	7.02	7.17	6.40	2.00	509
5 (120) ASME -1500 , WN / RTJ	8705 _ _ _ 050JM	22.94	22.94	22.94	14.75	9.61	7.02	7.17	6.20	2.00	325
5 (120) ASME -2500 , WN / RTJ	8705 _ _ _ 050JN	28.98	28.98	28.98	16.50	9.61	7.02	7.17	5.30	2.00	502

Table 49: 8705-M Flanged Sensor 6-in. to 24-in. weld neck flange—high pressure (P ≤ Class 2500)—Inches

SIZE, DESCRIPTION	MODEL NUMBER 	DIM			FLANGE Ø DIM "B"	BODY Ø DIM "C"	DIM "D" CL to TA		LINER Ø ON FACE DIM "J"	LIFT RING HEIGHT DIM "K"	FLOW TUBE WEIGHT (lbs.)
		"A" NEOPRENE	"A" LINATEX	"A" POLY			STYLE A	STYLE B			
6 (150) ASME - 600 FULL, WN / RF	8705 - - - 060D7	18.73	18.73	18.73	14.00	9.98	7.30	7.35	8.00	1.70	230
6 (150) ASME - 900 , WN / RF	8705 - - - 060D9	20.58	20.58	20.58	15.00	9.98	7.30	7.35	8.00	2.00	296
6 (150) ASME -1500 , WN / RF	8705 - - - 060DM	23.84	23.84	23.84	15.50	9.98	7.30	7.35	7.70	2.00	428
6 (150) ASME -2500 , WN / RF	8705 - - - 060DN	31.79	31.79	31.79	19.00	9.98	7.30	7.35	7.30	2.00	848
6 (150) ASME - 600 FULL, WN / RTJ	8705 - - - 060J7	18.89	18.89	18.89	14.00	9.98	7.30	7.35	7.12	1.70	232
6 (150) ASME - 900 , WN / RTJ	8705 - - - 060J9	20.74	20.74	20.74	15.00	9.98	7.30	7.35	7.12	2.00	299
6 (150) ASME -1500 , WN / RTJ	8705 - - - 060JM	24.12	24.12	24.12	15.50	9.98	7.30	7.35	6.73	2.00	433
6 (150) ASME -2500 , WN / RTJ	8705 - - - 060JN	32.32	32.32	32.32	19.00	9.98	7.30	7.35	6.66	2.00	863
8 (200) ASME - 600 FULL, WN / RF	8705 - - - 080D7	21.59	21.59	21.59	16.50	11.92	8.27	8.32	10.00	1.70	355
8 (200) ASME - 900 , WN / RF	8705 - - - 080D9	24.09	24.09	24.09	18.50	11.92	8.27	8.32	10.00	3.13	521
8 (200) ASME -1500 , WN / RF	8705 - - - 080DM	28.70	28.70	28.70	19.00	11.92	8.27	8.32	9.76	3.13	755
8 (200) ASME -2500 , WN / RF	8705 - - - 080DN	36.88	36.88	36.88	21.75	11.92	8.27	8.32	9.20	3.13	1352
8 (200) ASME - 600 FULL, WN / RTJ	8705 - - - 080J7	21.75	21.75	21.75	16.50	11.92	8.27	8.32	9.37	1.70	359
8 (200) ASME - 900 , WN / RTJ	8705 - - - 080J9	24.25	24.25	24.25	18.50	11.92	8.27	8.32	9.13	3.13	525
8 (200) ASME -1500 , WN / RTJ	8705 - - - 080JM	29.11	29.11	29.11	19.00	11.92	8.27	8.32	8.66	3.13	767
8 (200) ASME -2500 , WN / RTJ	8705 - - - 080JN	37.53	37.53	37.53	21.75	11.92	8.27	8.32	8.28	3.13	1377
10 (250) ASME - 600 FULL, WN / RF	8705 - - - 100D7	23.34	23.34	23.34	20.00	14.64	9.69	9.68	12.00	2.00	580
10 (250) ASME - 900 , WN / RF	8705 - - - 100D9	26.12	26.12	26.12	21.50	14.64	9.69	9.68	12.00	3.13	797
10 (250) ASME -1500 , WN / RF	8705 - - - 100DM	32.03	32.03	32.03	23.00	14.64	9.69	9.68	11.50	3.13	1317
10 (250) ASME -2500 , WN / RF	8705 - - - 100DN	44.95	44.95	44.95	26.50	14.64	9.69	9.68	10.65	3.13	2542
10 (250) ASME - 600 FULL, WN / RTJ	8705 - - - 100J7	23.50	23.50	23.50	20.00	14.64	9.69	9.68	11.50	2.00	585
10 (250) ASME - 900 , WN / RTJ	8705 - - - 100J9	26.28	26.28	26.28	21.50	14.64	9.69	9.68	11.25	3.13	803
10 (250) ASME -1500 , WN / RTJ	8705 - - - 100JM	32.44	32.44	32.44	23.00	14.64	9.69	9.68	10.78	3.13	1333
10 (250) ASME -2500 , WN / RTJ	8705 - - - 100JN	45.86	45.86	45.86	26.50	14.64	9.69	9.68	9.94	3.13	2597
12 (300) ASME - 600 FULL, WN / RF	8705 - - - 120D7	26.59	26.59	26.59	22.00	16.50	10.77	10.61	14.00	2.00	759
12 (300) ASME - 900 , WN / RF	8705 - - - 120D9	30.33	30.33	30.33	24.00	16.50	10.77	10.61	14.00	3.13	1112
12 (300) ASME -1500 , WN / RF	8705 - - - 120DM	37.11	37.11	37.11	26.50	16.50	10.77	10.61	13.18	3.13	2032
12 (300) ASME -2500 , WN / RF	8705 - - - 120DN	51.50	51.50	51.50	30.00	16.50	10.77	10.61	12.20	3.13	3860
12 (300) ASME - 600 FULL, WN / RTJ	8705 - - - 120J7	26.75	26.75	26.75	22.00	16.50	10.77	10.61	13.75	2.00	767
12 (300) ASME - 900 , WN / RTJ	8705 - - - 120J9	30.49	30.49	30.49	24.00	16.50	10.77	10.61	13.50	3.13	1120
12 (300) ASME -1500 , WN / RTJ	8705 - - - 120JM	37.76	37.76	37.76	26.50	16.50	10.77	10.61	12.28	3.13	2065
12 (300) ASME -2500 , WN / RTJ	8705 - - - 120JN	52.41	52.41	52.41	30.00	16.50	10.77	10.61	12.06	3.13	3938
14 (350) ASME - 600 FULL, WN / RF	8705 - - - 140D7	29.95	29.95	29.95	23.75	18.92	11.83	11.82	15.25	2.00	940
14 (350) ASME -1500 , WN / RF	8705 - - - 140DM	40.82	40.82	40.82	29.50	18.92	11.83	11.82	14.06	3.13	2662
14 (350) ASME - 600 FULL, WN / RTJ	8705 - - - 140J7	30.11	30.11	30.11	23.75	18.92	11.83	11.82	15.00	2.00	951
16 (400) ASME - 600 FULL, WN / RF	8705 - - - 160D7	33.23	33.23	33.23	27.00	20.94	12.84	12.83	17.50	3.13	1277
16 (400) ASME -1500 , WN / RF	8705 - - - 160DM	43.96	43.96	43.96	32.50	20.94	12.84	12.83	18.50	3.13	3485
16 (400) ASME - 600 FULL, WN / RTJ	8705 - - - 160J7	33.39	33.39	33.39	27.00	20.94	12.84	12.83	17.00	3.13	1287
18 (450) ASME - 600 FULL, WN / RF	8705 - - - 180D7	34.89	34.89	34.89	29.25	23.46	14.10	14.09	20.00	3.13	1534
18 (450) ASME -1500 , WN / RF	8705 - - - 180DM	46.23	46.23	46.23	36.00	23.46	14.10	14.09	21.00	3.38	4416
18 (450) ASME - 600 FULL, WN / RTJ	8705 - - - 180J7	35.05	35.05	35.05	29.25	23.46	14.10	14.09	19.38	3.13	1545
20 (500) ASME - 600 FULL, WN / RF	8705 - - - 200D7	37.93	37.93	37.93	32.00	25.48	15.11	15.10	22.00	3.13	1895
20 (500) ASME -1500 , WN / RF	8705 - - - 200DM	50.81	50.81	50.81	38.75	25.48	15.11	15.10	21.10	3.38	5479
20 (500) ASME - 600 FULL, WN / RTJ	8705 - - - 200J7	38.21	38.21	38.21	32.00	25.48	15.11	15.10	21.00	3.13	1917
24 (600) ASME - 600 FULL, WN / RF	8705 - - - 240D7	41.99	41.99	41.99	37.00	30.03	17.39	17.38	26.00	3.13	2848
24 (600) ASME -1500 , WN / RF	8705 - - - 240DM	57.94	57.94	57.94	46.00	30.03	17.39	17.38	25.50	3.38	8822
24 (600) ASME - 600 FULL, WN / RTJ	8705 - - - 240J7	42.40	42.40	42.40	37.00	30.03	17.39	17.38	25.00	3.13	2890

Table 50: 8705-M Flanged Sensor DN 25mm to120mm weld neck flange—high pressure (P ≤ Class 2500)—Millimeters

SIZE, DESCRIPTION	MODEL NUMBER 				FLANGE Ø DIM "B"	BODY Ø DIM "C"	DIM "D" CL to TA		LINER Ø ON FACE DIM "J"	LIFT RING HEIGHT DIM "K"	FLOW TUBE WEIGHT (kg)
		DIM "A" NEOPRENE	DIM "A" LINATEX	DIM "A" POLY			STYLE A	STYLE B			
1 (25) ASME - 600 FULL, WN / RF	8705 _ _ _ 010D7	293	293	293	124	114	112	117	51		8
1 (25) ASME - 900 , WN / RF	8705 _ _ _ 010D9	318	318	318	149	114	112	117	51	43	12
1 (25) ASME -1500 , WN / RF	8705 _ _ _ 010DM	327	327	327	149	114	112	117	41	43	11
1 (25) ASME -2500 , WN / RF	8705 _ _ _ 010DN	363	363	363	159	114	112	117	41	43	15
1 (25) ASME - 600 FULL, WN / RTJ	8705 _ _ _ 010J7	294	294	294	124	114	112	117	33		8
1 (25) ASME - 900 , WN / RTJ	8705 _ _ _ 010J9	319	319	319	149	114	112	117	33	43	12
1 (25) ASME -1500 , WN / RTJ	8705 _ _ _ 010JM	328	328	328	149	114	112	117	32	43	12
1.5 (40) ASME - 600 FULL, WN / RF	8705 _ _ _ 015D7	294	294	294	155	132	122	126	64		12
1.5 (40) ASME - 900 , WN / RF	8705 _ _ _ 015D9	321	321	321	178	132	122	126	64	43	17
1.5 (40) ASME -1500 , WN / RF	8705 _ _ _ 015DM	332	332	332	178	132	122	126	64	43	18
1.5 (40) ASME -2500 , WN / RF	8705 _ _ _ 015DN	394	394	394	203	132	122	126	60	43	30
1.5 (40) ASME - 600 FULL, WN / RTJ	8705 _ _ _ 015J7	294	294	294	155	132	122	126	51		12
1.5 (40) ASME - 900 , WN / RTJ	8705 _ _ _ 015J9	322	322	322	178	132	122	126	51	43	17
1.5 (40) ASME -1500 , WN / RTJ	8705 _ _ _ 015JM	333	333	333	178	132	122	126	49	43	18
1.5 (40) ASME -2500 , WN / RTJ	8705 _ _ _ 015JN	398	398	398	203	132	122	126	47	43	31
2 (50) ASME - 600 FULL, WN / RF	8705 _ _ _ 020D7	301	301	301	165	132	122	126	83		14
2 (50) ASME - 900 , WN / RF	8705 _ _ _ 020D9	362	362	362	216	132	122	126	83	43	30
2 (50) ASME -1500 , WN / RF	8705 _ _ _ 020DM	376	376	376	216	132	122	126	83	43	31
2 (50) ASME -2500 , WN / RF	8705 _ _ _ 020DN	428	428	428	235	132	122	126	79	43	43
2 (50) ASME - 600 FULL, WN / RTJ	8705 _ _ _ 020J7	305	305	305	165	132	122	126	59		15
2 (50) ASME - 900 , WN / RTJ	8705 _ _ _ 020J9	366	366	366	216	132	122	126	67	43	30
2 (50) ASME -1500 , WN / RTJ	8705 _ _ _ 020JM	379	379	379	216	132	122	126	60	43	32
2 (50) ASME -2500 , WN / RTJ	8705 _ _ _ 020JN	432	432	432	235	132	122	126	66	43	44
2.5 (60) ASME -1500 , WN / RF	8705 _ _ _ 025DM	427	427	427	244	160	136	140	94	43	42
2.5 (60) ASME -2500 , WN / RF	8705 _ _ _ 025DN	500	500	500	267	160	136	140	89	43	62
2.5 (60) ASME -1500 , WN / RTJ	8705 _ _ _ 025JM	430	430	430	244	160	136	140	79	43	40
2.5 (60) ASME -2500 , WN / RTJ	8705 _ _ _ 025JN	506	506	506	267	160	136	140	71	43	60
3 (80) ASME - 600 FULL, WN / RF	8705 _ _ _ 030D7	325	325	325	210	183	148	152	117	43	27
3 (80) ASME - 900 , WN / RF	8705 _ _ _ 030D9	365	365	365	241	183	148	152	117	43	38
3 (80) ASME -1500 , WN / RF	8705 _ _ _ 030DM	413	413	413	267	183	148	152	110	43	57
3 (80) ASME -2500 , WN / RF	8705 _ _ _ 030DN	519	519	519	305	183	148	152	105	43	96
3 (80) ASME - 600 FULL, WN / RTJ	8705 _ _ _ 030J7	329	329	329	210	183	148	152	102	43	27
3 (80) ASME - 900 , WN / RTJ	8705 _ _ _ 030J9	369	369	369	241	183	148	152	100	43	39
3 (80) ASME -1500 , WN / RTJ	8705 _ _ _ 030JM	417	417	417	267	183	148	152	101	43	58
3 (80) ASME -2500 , WN / RTJ	8705 _ _ _ 030JN	526	526	526	305	183	148	152	87	43	97
4 (100) ASME - 600 FULL, WN / RF	8705 _ _ _ 040D7	396	396	396	273	201	157	160	148	43	49
4 (100) ASME - 900 , WN / RF	8705 _ _ _ 040D9	427	427	427	292	201	157	160	148	51	64
4 (100) ASME -1500 , WN / RF	8705 _ _ _ 040DM	462	462	462	311	201	157	160	145	51	85
4 (100) ASME -2500 , WN / RF	8705 _ _ _ 040DN	602	602	602	356	201	157	160	141	51	150
4 (100) ASME - 600 FULL, WN / RTJ	8705 _ _ _ 040J7	400	400	400	273	201	157	160	125	43	49
4 (100) ASME - 900 , WN / RTJ	8705 _ _ _ 040J9	431	431	431	292	201	157	160	125	51	64.1
4 (100) ASME -1500 , WN / RTJ	8705 _ _ _ 040JM	466	466	466	311	201	157	160	141	51	86.7
4 (100) ASME -2500 , WN / RTJ	8705 _ _ _ 040JN	613	613	613	356	201	157	160	111	51	153.1
5 (120) ASME -1500 , WN / RF	8705 _ _ _ 050DM	579	579	579	375	244	178	182	161	51	150.2
5 (120) ASME -2500 , WN / RF	8705 _ _ _ 050DN	723	723	723	419	244	178	182	163	51	231.0
5 (120) ASME -1500 , WN / RTJ	8705 _ _ _ 050JM	583	583	583	375	244	178	182	157	51	147.4
5 (120) ASME -2500 , WN / RTJ	8705 _ _ _ 050JN	736	736	736	419	244	178	182	135	51	227.6

Table 51: 8705-M Flanged Sensor (DN 150mm to 600mm) weld neck flange—high pressure (P ≤ Class 2500)—Millimeters

SIZE, DESCRIPTION	MODEL NUMBER 				FLANGE Ø DIM "B"	BODY Ø DIM "C"	DIM "D" CL to TA		LINER Ø ON FACE DIM "J"	LIFT RING HEIGHT DIM "K"	FLOW TUBE WEIGHT (kg)
		DIM "A" NEOPRENE	DIM "A" LINATEX	DIM "A" POLY			STYLE A	STYLE B			
6 (150) ASME - 600 FULL, WN / RF	8705 _ _ _ 060D7	476	476	476	356	253	185	187	203	43	104
6 (150) ASME - 900 , WN / RF	8705 _ _ _ 060D9	523	523	523	381	253	185	187	203	51	134
6 (150) ASME -1500 , WN / RF	8705 _ _ _ 060DM	605	605	605	394	253	185	187	196	51	194
6 (150) ASME -2500 , WN / RF	8705 _ _ _ 060DN	807	807	807	483	253	185	187	185	51	384
6 (150) ASME - 600 FULL, WN / RTJ	8705 _ _ _ 060J7	480	480	480	356	253	185	187	181	43	105
6 (150) ASME - 900 , WN / RTJ	8705 _ _ _ 060J9	527	527	527	381	253	185	187	181	51	135
6 (150) ASME -1500 , WN / RTJ	8705 _ _ _ 060JM	613	613	613	394	253	185	187	171	51	196
6 (150) ASME -2500 , WN / RTJ	8705 _ _ _ 060JN	821	821	821	483	253	185	187	169	51	392
8 (200) ASME - 600 FULL, WN / RF	8705 _ _ _ 080D7	548	548	548	419	303	210	211	254	43	161
8 (200) ASME - 900 , WN / RF	8705 _ _ _ 080D9	612	612	612	470	303	210	211	254	80	236
8 (200) ASME -1500 , WN / RF	8705 _ _ _ 080DM	729	729	729	483	303	210	211	248	80	342
8 (200) ASME -2500 , WN / RF	8705 _ _ _ 080DN	937	937	937	552	303	210	211	234	80	613
8 (200) ASME - 600 FULL, WN / RTJ	8705 _ _ _ 080J7	552	552	552	419	303	210	211	238	43	163
8 (200) ASME - 900 , WN / RTJ	8705 _ _ _ 080J9	616	616	616	470	303	210	211	232	80	238
8 (200) ASME -1500 , WN / RTJ	8705 _ _ _ 080JM	739	739	739	483	303	210	211	220	80	348
8 (200) ASME -2500 , WN / RTJ	8705 _ _ _ 080JN	953	953	953	552	303	210	211	210	80	625
10 (250) ASME - 600 FULL, WN / RF	8705 _ _ _ 100D7	593	593	593	508	372	246	246	305	51	263
10 (250) ASME - 900 , WN / RF	8705 _ _ _ 100D9	663	663	663	546	372	246	246	305	80	362
10 (250) ASME -1500 , WN / RF	8705 _ _ _ 100DM	813	813	813	584	372	246	246	292	80	597
10 (250) ASME -2500 , WN / RF	8705 _ _ _ 100DN	1142	1142	1142	673	372	246	246	271	80	1153
10 (250) ASME - 600 FULL, WN / RTJ	8705 _ _ _ 100J7	597	597	597	508	372	246	246	292	51	265
10 (250) ASME - 900 , WN / RTJ	8705 _ _ _ 100J9	668	668	668	546	372	246	246	286	80	364
10 (250) ASME -1500 , WN / RTJ	8705 _ _ _ 100JM	824	824	824	584	372	246	246	274	80	605
10 (250) ASME -2500 , WN / RTJ	8705 _ _ _ 100JN	1165	1165	1165	673	372	246	246	252	80	1178
12 (300) ASME - 600 FULL, WN / RF	8705 _ _ _ 120D7	675	675	675	559	419	274	269	356	51	344
12 (300) ASME - 900 , WN / RF	8705 _ _ _ 120D9	770	770	770	610	419	274	269	356	80	505
12 (300) ASME -1500 , WN / RF	8705 _ _ _ 120DM	942	942	942	673	419	274	269	335	80	922
12 (300) ASME -2500 , WN / RF	8705 _ _ _ 120DN	1308	1308	1308	762	419	274	269	310	80	1751
12 (300) ASME - 600 FULL, WN / RTJ	8705 _ _ _ 120J7	679	679	679	559	419	274	269	349	51	348
12 (300) ASME - 900 , WN / RTJ	8705 _ _ _ 120J9	774	774	774	610	419	274	269	343	80	508
12 (300) ASME -1500 , WN / RTJ	8705 _ _ _ 120JM	959	959	959	673	419	274	269	312	80	937
12 (300) ASME -2500 , WN / RTJ	8705 _ _ _ 120JN	1331	1331	1331	762	419	274	269	306	80	1786
14 (350) ASME - 600 FULL, WN / RF	8705 _ _ _ 140D7	761	761	761	603	481	300	300	387	51	426
14 (350) ASME -1500 , WN / RF	8705 _ _ _ 140DM	1037	1037	1037	749	481	300	300	357	80	1208
14 (350) ASME - 600 FULL, WN / RTJ	8705 _ _ _ 140J7	765	765	765	603	481	300	300	381	51	431
16 (400) ASME - 600 FULL, WN / RF	8705 _ _ _ 160D7	844	844	844	686	532	326	326	445	80	579
16 (400) ASME -1500 , WN / RF	8705 _ _ _ 160DM	1116	1116	1116	826	532	326	326	470	80	1581
16 (400) ASME - 600 FULL, WN / RTJ	8705 _ _ _ 160J7	848	848	848	686	532	326	326	432	80	584
18 (450) ASME - 600 FULL, WN / RF	8705 _ _ _ 180D7	886	886	886	743	596	358	358	508	80	696
18 (450) ASME -1500 , WN / RF	8705 _ _ _ 180DM	1174	1174	1174	914	596	358	358	533	86	2003
18 (450) ASME - 600 FULL, WN / RTJ	8705 _ _ _ 180J7	890	890	890	743	596	358	358	492	80	701
20 (500) ASME - 600 FULL, WN / RF	8705 _ _ _ 200D7	963	963	963	813	647	384	384	559	80	860
20 (500) ASME -1500 , WN / RF	8705 _ _ _ 200DM	1290	1290	1290	984	647	384	384	536	86	2485
20 (500) ASME - 600 FULL, WN / RTJ	8705 _ _ _ 200J7	971	971	971	813	647	384	384	533	80	870
24 (600) ASME - 600 FULL, WN / RF	8705 _ _ _ 240D7	1067	1067	1067	940	763	442	441	660	80	1292
24 (600) ASME -1500 , WN / RF	8705 _ _ _ 240DM	1472	1472	1472	1168	763	442	441	648	86	4002
24 (600) ASME - 600 FULL, WN / RTJ	8705 _ _ _ 240J7	1077	1077	1077	940	763	442	441	635	80	1311

Figure 21: 8705-M Flanged Sensor 1/2-in. to 36-in. (DN 15mm to 900mm) M2/M4 coil housing (P ≤ Class 2500)

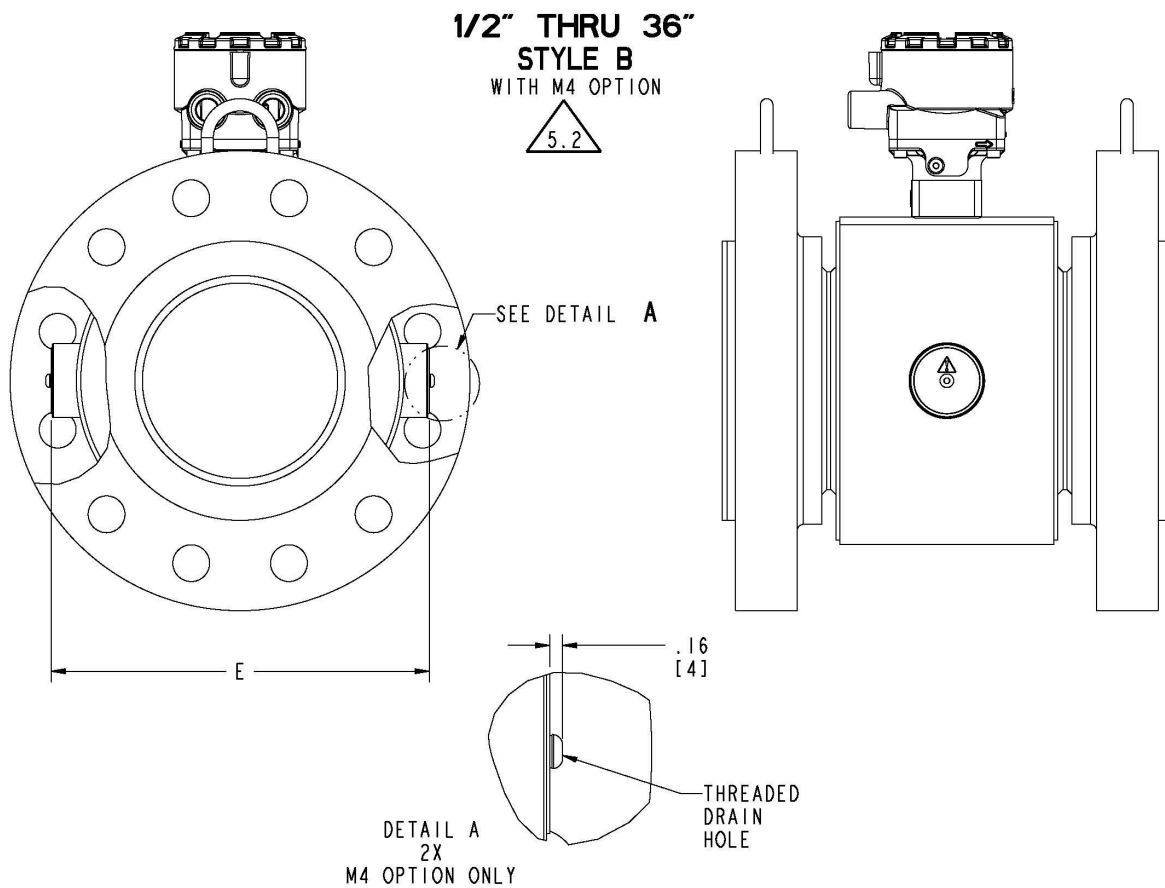
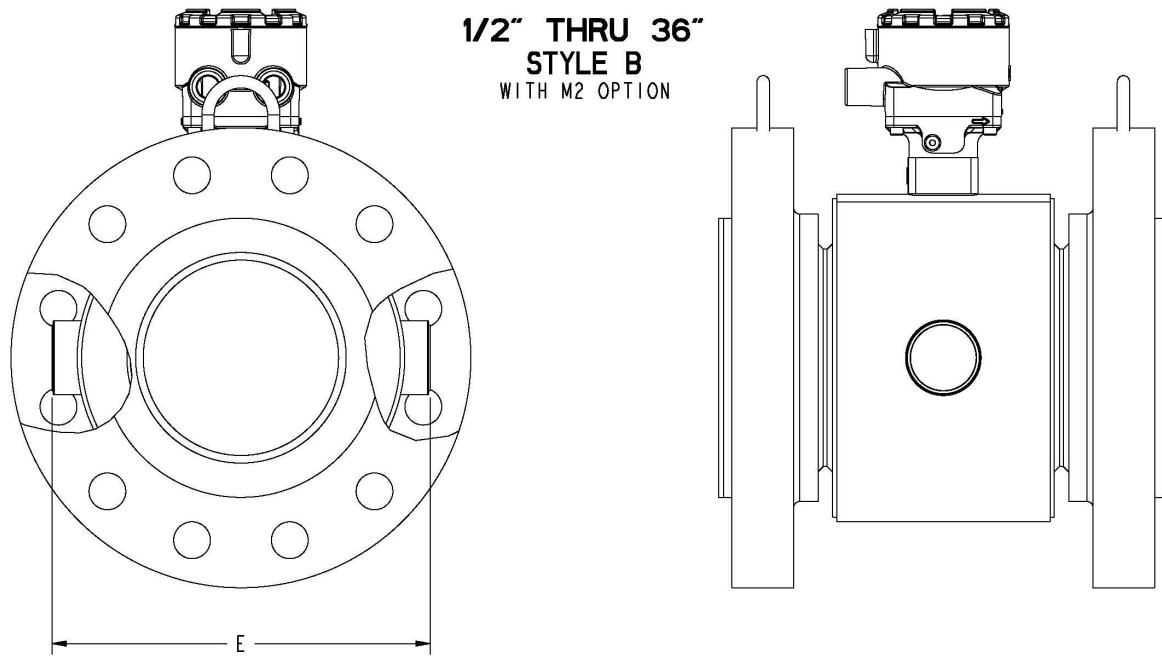

Table 52: 8705-M Flanged Sensor 1/2 -in. to 36-in. (DN 15mm to 900mm) M2/M4 coil housing (P ≤ Class 2500)

TABLE 52 BODY WIDTH WITH ELECTRODE ACCESS (M2)		
SIZE - IN (mm) ALL FLANGES	BODY WIDTH W/ M2 DIM "E" (INCH)	BOD WIDTH W/ M2 DIM "E" (mm)
4 (100)	8.65	220
5 (125)	9.71	247
6 (150)	10.62	270
8 (200)	12.62	321
10 (250)	15.53	394
12 (300)	17.53	445
14 (350)	20.68	525
16 (400)	22.68	576
18 (450)	24.68	627
20 (500)	26.68	678
24 (600)	30.68	779
30 (750)	36.68	932
36 (900)	44.18	1122

5.2 WHEN VENTING THE ELECTRODE COMPARTMENT, THE VENT AND RECOVERY PIPING DIAMETER MUST NOT BE SMALLER THAN THE M6 COVER THREADING TO AVOID BUILDING PRESSURE INSIDE THE ELECTRODE COMPARTMENT.

5.1 WHEN M4 OPTION IS SELECTED ADD .320 (8mm) TO M2 DIM "E" (BODY WIDTH DIMENSION)

Figure 22: 8705-M Flanged Sensor 1/2-in. to 36-in. (DN 15mm to 900mm) lining protectors—(P ≤ Class 900)

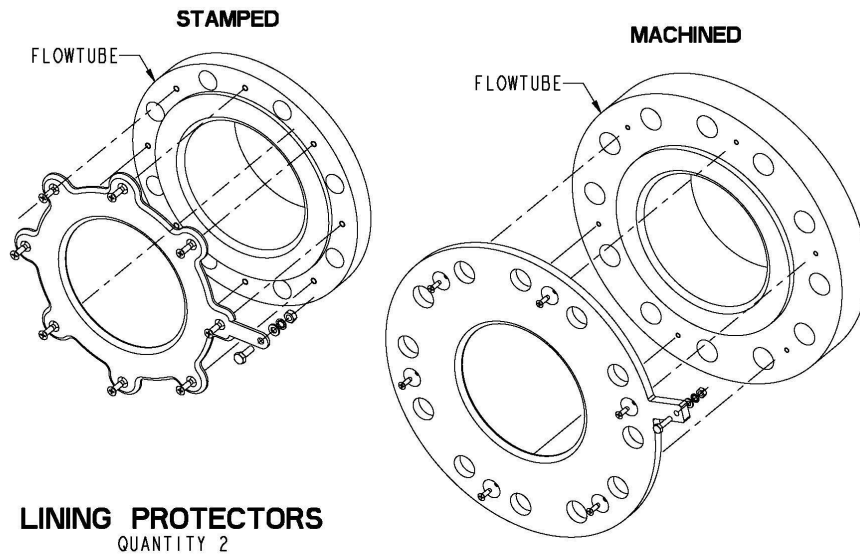

Line Size in (mm)	LINING PROTECTOR THICKNESS 9.1			
	THICKNESS (QTY 1) ADD VALUE TO "DIM A" (OVERALL LENGTH)		THICKNESS (QTY 2) ADD VALUE TO "DIM A" (OVERALL LENGTH)	
	MIN	MAX	MIN	MAX
0.5 (15)	0.087	0.134	0.174	0.268
1 (25)	0.084	0.130	0.168	0.260
1.5 (40)	0.105	0.190	0.210	0.380
2 (50)	0.105	0.190	0.210	0.380
2.5 (60)	0.105	0.190	0.210	0.380
3 (80)	0.105	0.190	0.210	0.380
4 (100)	0.105	0.190	0.210	0.380
5 (125)	0.128	0.190	0.256	0.380
6 (150)	0.100	0.190	0.200	0.380
8 (200)	0.090	0.190	0.180	0.380
10 (250)	0.110	0.185	0.220	0.370
12 (300)	0.110	0.185	0.220	0.370
14 (350)	0.150	0.185	0.300	0.370
16 (400)	0.150	0.185	0.300	0.370
18 (450)	0.150	0.162	0.300	0.324
20 (500)	0.150	0.162	0.300	0.324
24 (600)	0.150	0.162	0.300	0.324
30 (750)	0.285	0.285	0.570	0.570
36 (900)	0.410	0.410	0.820	0.820

9.2 ADDITIONAL LENGTH DOES NOT INCLUDE CUSTOMER SUPPLIED GASKET.

9.1 ACTUAL VALUE DEPENDENT UPON FLANGE RATING AND MATERIAL OF CONSTRUCTION; CONSULT FACTORY FOR EXACT DIMENSIONS.

Figure 23: 8705-M Flanged Sensor 1/2 -in. to 36-in. (DN 15mm to 900mm) ground rings—(P ≤ Class 900)

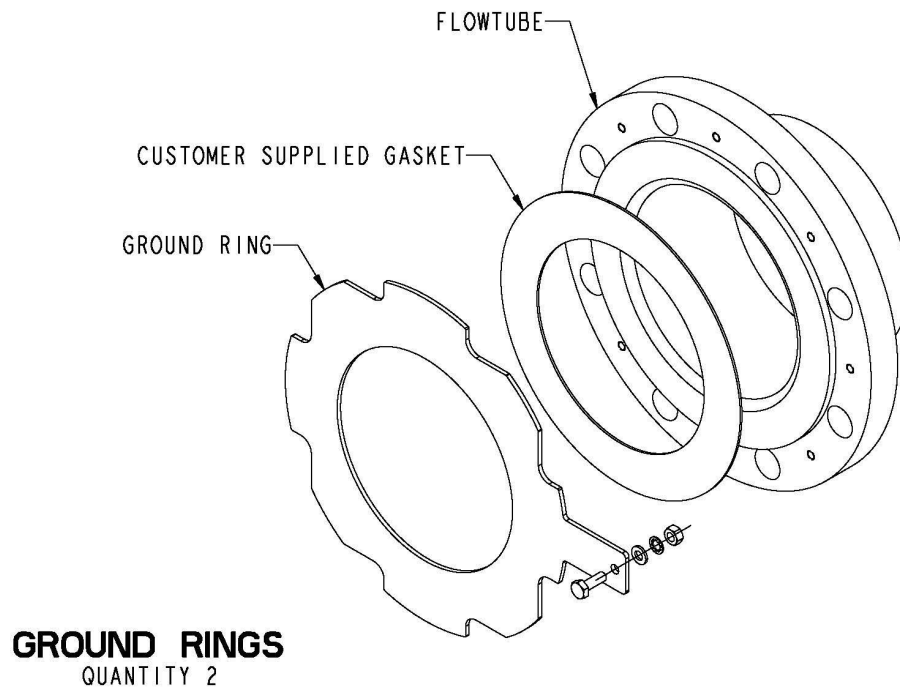

GROUND RING THICKNESS				
Line Size in (mm)	THICKNESS (QTY 1) ADD VALUE TO "DIM A" (OVERALL LENGTH)		THICKNESS (QTY 2) ADD VALUE TO "DIM A" (OVERALL LENGTH)	
	MIN	MAX	MIN	MAX
	0.5 (15)	0.045	0.120	0.090
1 (25)	0.045	0.120	0.090	0.240
1.5 (40)	0.045	0.120	0.090	0.240
2 (50)	0.045	0.120	0.090	0.240
2.5 (60)	0.059	0.120	0.118	0.240
3 (80)	0.045	0.120	0.090	0.240
4 (100)	0.045	0.120	0.090	0.240
5 (125)	0.059	0.120	0.118	0.240
6 (150)	0.045	0.120	0.090	0.240
8 (200)	0.045	0.120	0.090	0.240
10 (250)	0.045	0.120	0.090	0.240
12 (300)	0.045	0.120	0.090	0.240
14 (350)	0.045	0.250	0.090	0.500
16 (400)	0.045	0.250	0.090	0.500
18 (450)	0.120	0.250	0.240	0.500
20 (500)	0.120	0.250	0.240	0.500
24 (600)	0.187	0.250	0.374	0.500
30 (750)	0.187	0.250	0.374	0.500
36 (900)	0.187	0.250	0.374	0.500

8711-M/L dimensions

Figure 24: 8711-M/L Wafer Sensor 1½ -in. to 8-in. (DN 40mm to 200mm) wafer—(P ≤ Class 300)

I.S. WAFER MAGMETER 1.5" TO 8" STYLE B

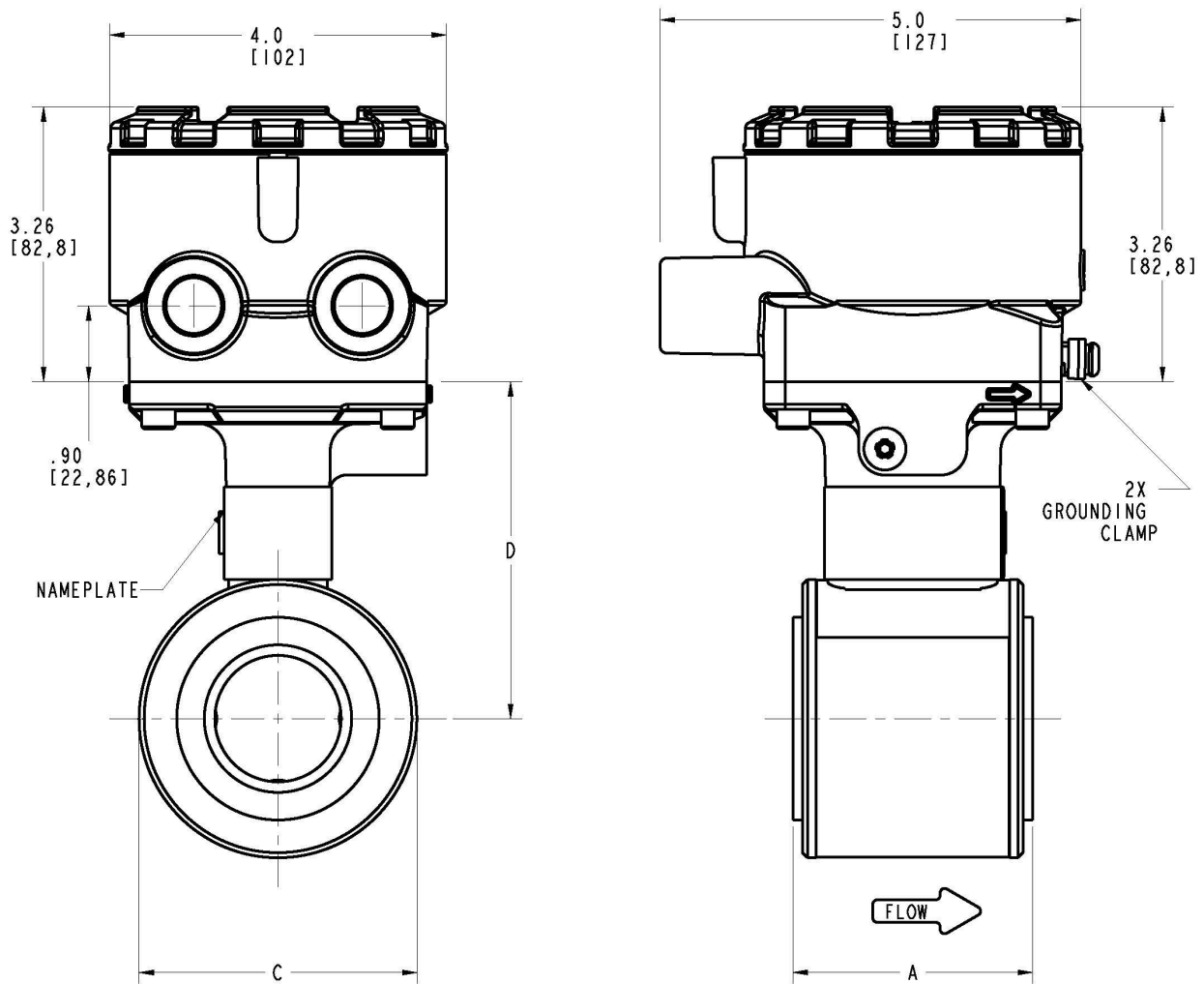

Table 53: 8711-M/L Wafer Sensor 1½ -in. to 8-in. (DN 40mm to 200mm) wafer—(P ≤ Class 300)

Size, description	See Figure 24.						
	Overall length		Body Ø DIM ©	DIM ⓓ CL to tube adapter		Liner Ø on face DIM Ⓧ	Sensor weight in lbs. (kg)
	DIM Ⓐ PTFE	DIM Ⓐ ETFE		Style A	Style B		
1½ (40) WAFER UP TO ASME - 300# / EN 1092-1 PN40	2.88 (73)	2.73 (69)	3.29 (84)	4.00 (102)	4.00 (102)	2.42 (61)	5 (2.3)
2 (20) WAFER UP TO ASME - 300# / EN 1092-1 PN40	3.32 (84)	3.26 (83)	3.92 (99)	4.23 (107)	4.32 (110)	3.05 (77)	7 (3.2)

Table 53: 8711-M/L Wafer Sensor 1 ½ -in. to 8-in. (DN 40mm to 200mm) wafer—(P ≤ Class 300) (continued)

Size, description	See Figure 24 .						
	Overall length		Body Ø DIM ©	DIM Ⓣ CL to tube adapter		Liner Ø on face DIM Ⓟ	Sensor weight in lbs. (kg)
	DIM Ⓐ PTFE	DIM Ⓐ ETFE		Style A	Style B		
3 (80) WAFER UP TO ASME - 300# / EN 1092-1 PN40	4.82 (122)	4.62 (117)	5.17 (131)	4.87 (124)	4.95 (126)	4.41 (112)	13 (5.9)
4 (100) WAFER UP TO ASME - 300# / EN 1092-1 PN40	6.03 (153)	5.83 (148)	6.39 (162)	5.50 (140)	5.56 (141)	5.80 (147)	22 (10.0)
6 (150) WAFER UP TO ASME - 300# / EN 1092-1 PN40	7.08 (180)	6.87 (174)	8.57 (218)	6.22 (158)	6.65 (169)	7.86 (200)	35 (15.9)
8 (200) WAFER UP TO ASME - 300# / EN 1092-1 PN40	9.06 (230)	8.86 (225)	10.63 (270)	7.25 (184)	7.68 (195)	9.86 (250)	60 (27.2)

8711-R/U dimensions

Figure 25: 8711-R/U Wafer Sensor 0.15 in. to 1 in. (DN 4 mm to 25 mm) wafer—(P ≤ Class 300)

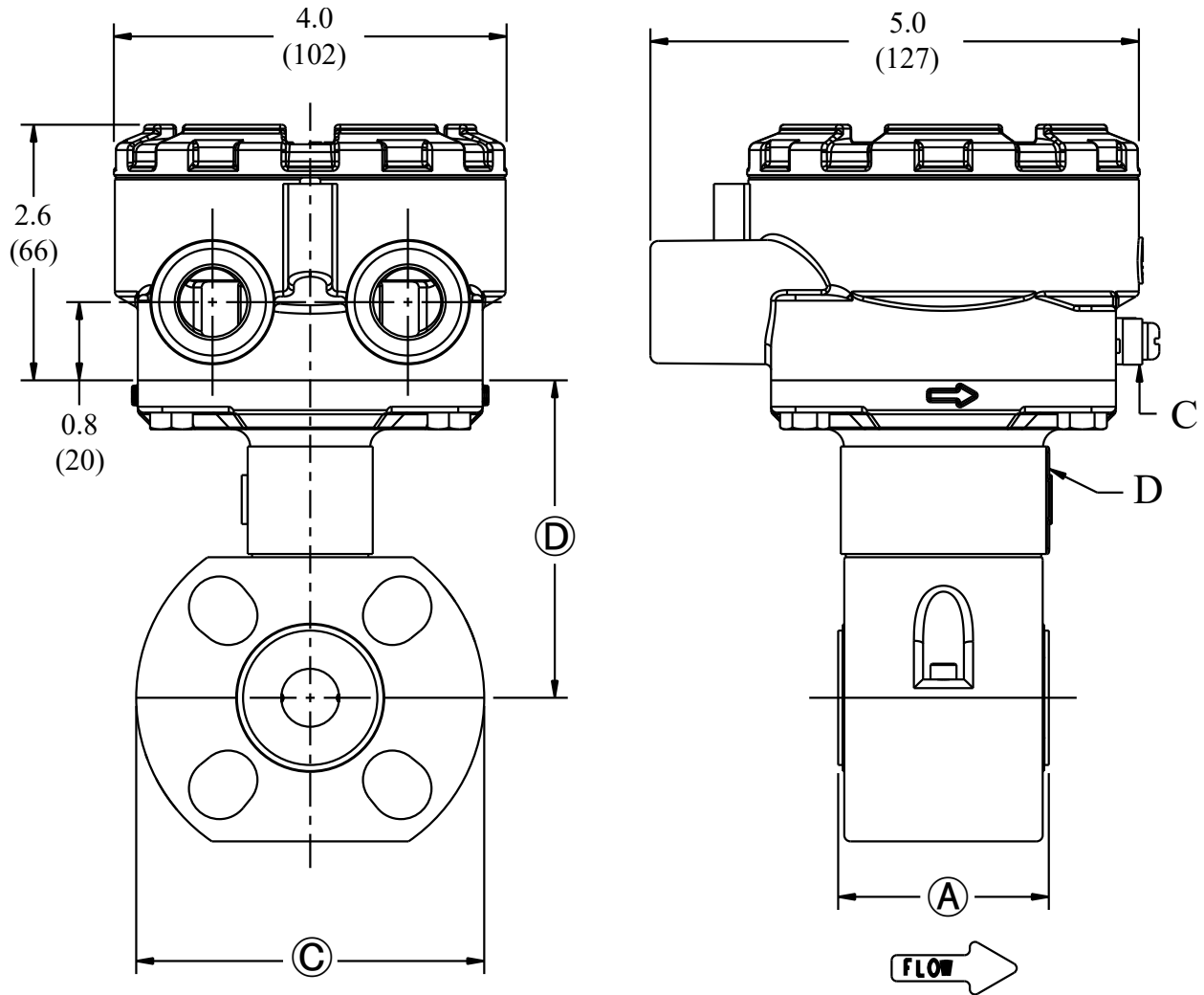

- A. Grounding clamp
- B. Nameplate

See [Table 54](#) for Dimensions A, C, D, and ØJ.

Table 54: 8711-R/U variable dimensions in inches (mm)

Size, description	See Figure 25 .						
	Overall length			Body Ø DIM ©	CL to UMB DIM ④	Liner Ø on face DIM ⑤	Sensor weight in lbs. (kg)
	DIM ① PTFE	DIM ② ETFE	DIM ③ PFA				
0.15 (4) WAFER UP TO ASME - 150# / EN 1092-1 PN16			2.17 (55)	3.56 (90)	3.25 (83)	1.37 (35)	4 (1.8)
0.30 (8) WAFER UP TO ASME - 150# / EN 1092-1 PN16			2.17 (55)	3.56 (90)	3.25 (83)	1.37 (35)	4 (1.8)
½ (15) WAFER UP TO ASME - 300# / EN 1092-1 PN40	2.21 (56)	2.16 (55)		3.56 (90)	3.25 (83)	1.38 (35)	4 (1.8)
1 (25) WAFER UP TO ASME - 300# / EN 1092-1 PN40	2.26 (57)	2.13 (54)		4.50 (114)	3.56 (90)	1.94 (49)	5 (2.3)

8721 dimensions

Figure 26: 8721 Hygienic (Sanitary) Sensor ½-in. to 4-in. (15 mm to 100 mm)

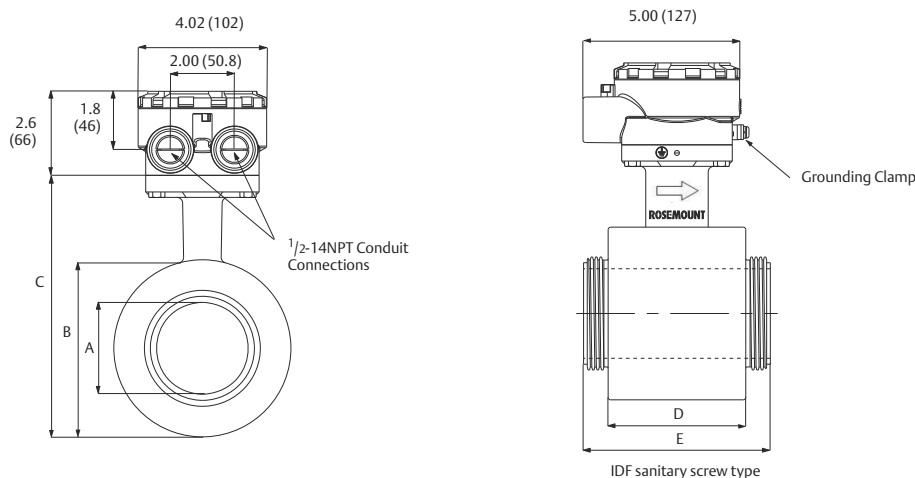
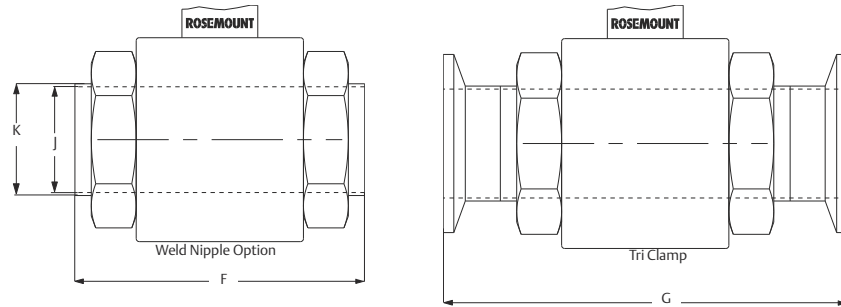

Table 55: 8721 Hygienic (Sanitary) Sensor ½-in. to 4-in. (15 mm to 100 mm)

Line size	Sensor dimensions A	Body diameter B	Sensor height C	Body length D	IDF length E
	Figure 26	Figure 26	Figure 26	Figure 26	Figure 26
½ (15)	0.62 (16)	3.16 (80)	5.62 (143)	2.13 (55)	3.66 (93)
1 (25)	0.87 (22)	3.16 (80)	5.62 (143)	2.13 (54)	3.66 (93)
1½ (40)	1.37 (35)	3.64 (93)	6.09 (155)	2.40 (61)	3.98 (101)
2 (50)	1.87 (48)	4.22 (107)	6.65 (169)	2.84 (72)	4.41 (112)
2 1/2 (65)	2.38 (60)	4.49 (114)	6.92 (176)	3.58 (91)	5.24 (133)
3 (80)	2.87 (73)	5.44 (138)	7.78 (198)	4.41 (112)	5.98 (152)
4 (100)	3.84 (98)	6.47 (164)	8.88 (226)	5.20 (132)	6.77 (172)

Figure 27: 8721 Hygienic (Sanitary) Sensor Weld Nipple and Tri Clamp



Note

Dimensions are in inches (millimeters).

Table 56: Overall Flowtube Length for all Fittings

Process connection code		A	B	C	D	E
Line size code	Nominal line size	Tri-Clamp	IDF Sanitary screw types	Weld Nipple per ASTM A 270	DIN 11851 (Imperial)	DIN 11851 (Metric)
005	0.5 (15)	7.86 (200)	3.66 (93)	5.61 (142)	7.88 (200)	6.77 (172)
010	1 (25)	7.85 (199)	3.66 (93)	5.61 (142)	7.89 (200)	7.89 (200)
015	1.5 (40)	8.17 (207)	3.98 (101)	5.92 (150)	8.53 (217)	8.53 (217)
020	2 (50)	8.60 (218)	4.41 (112)	6.35 (161)	9.10 (231)	9.10 (231)
025	2.5 (65)	9.43 (239)	5.24 (133)	7.18 (182)	10.33 (262)	10.33 (262)
030	3 (80)	10.18 (258)	5.98 (152)	7.93 (201)	11.48 (291)	11.48 (291)
040	4 (100)	11.70 (297)	6.77 (172)	9.46 (240)	13.72 (349)	13.72 (349)

Process connection code		F	G	H	J	K
Line size code	Nominal line size	DIN 11864-1 Form A	DIN 11864-2 Form A	SMS 1145	Cherry Burrell I-line	Weld Nipple per DIN 11850
005	0.5 (15)	N/A	N/A	N/A	N/A	5.61 (142)
010	1 (25)	8.99 (228)	8.87 (225)	6.87 (174)	7.17 (182)	9.61 (244)
015	1.5 (40)	9.75 (248)	9.59 (244)	7.50 (190)	7.80 (198)	9.92 (252)
020	2 (50)	10.18 (259)	10.02 (255)	7.93 (201)	8.42 (214)	10.75 (273)
025	2.5 (65)	11.91 (302)	11.55 (293)	9.07 (230)	9.49 (241)	11.58 (294)
030	3 (80)	12.98 (330)	12.46 (316)	9.82 (249)	10.37 (263)	12.33 (313)
040	4 (100)	14.50 (368)	14.14 (359)	11.89 (302)	12.15 (309)	13.86 (352)

Figure 28: 8721 Hygienic (Sanitary) Sensor DIN 11851 (Imperial)

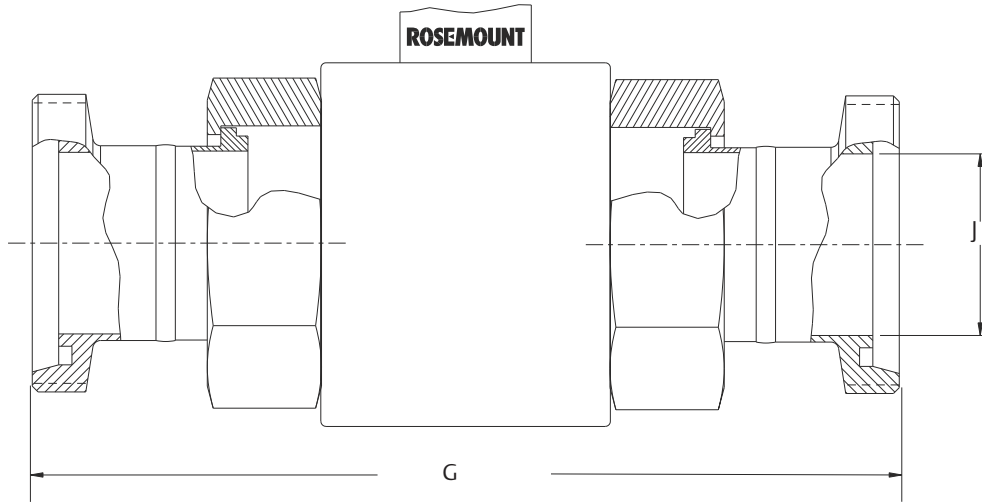

Figure 29: 8721 Hygienic (Sanitary) Sensor DIN 11851 (Metric)

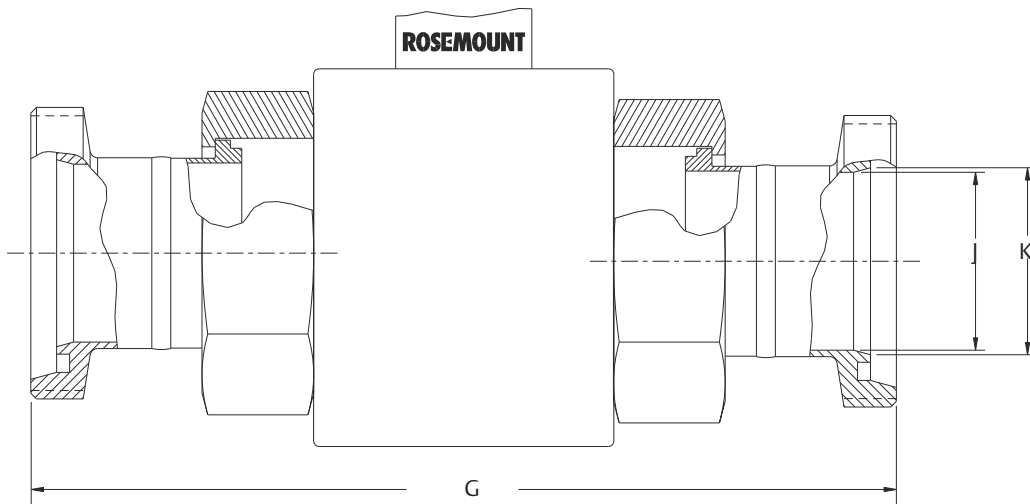

Figure 30: 8721 Hygienic (Sanitary) Sensor DIN 11864-1

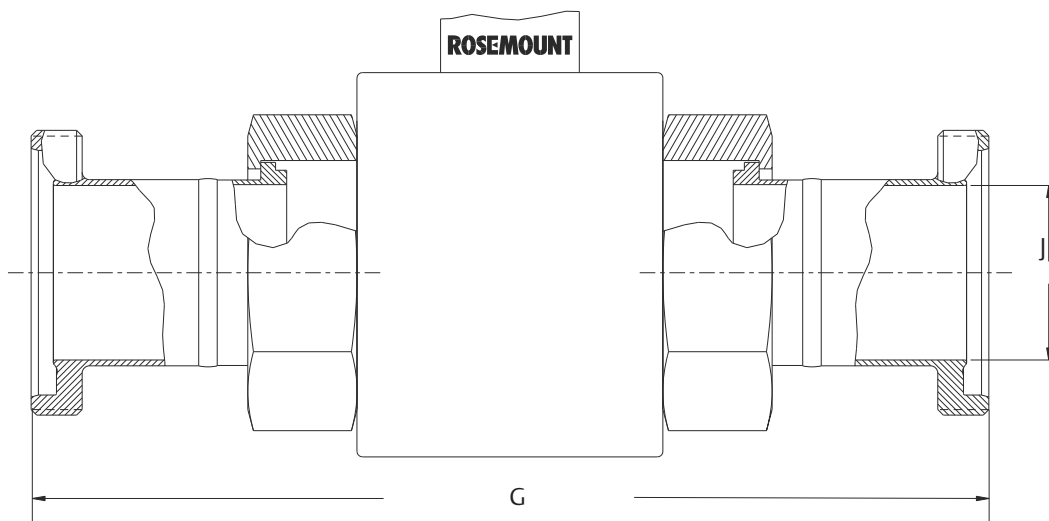

Figure 31: 8721 Hygienic (Sanitary) Sensor DIN 11864-2

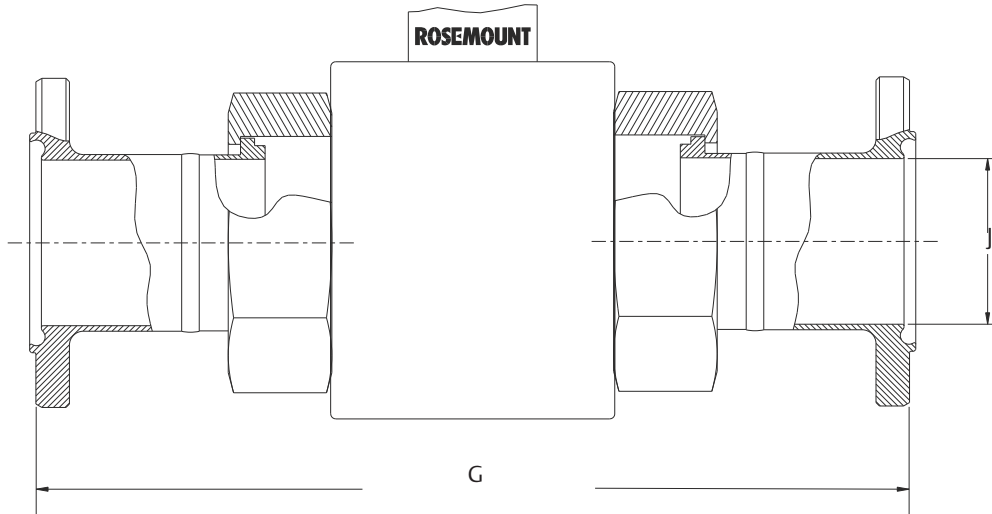

Figure 32: 8721 Hygienic (Sanitary) Sensor SMS1145

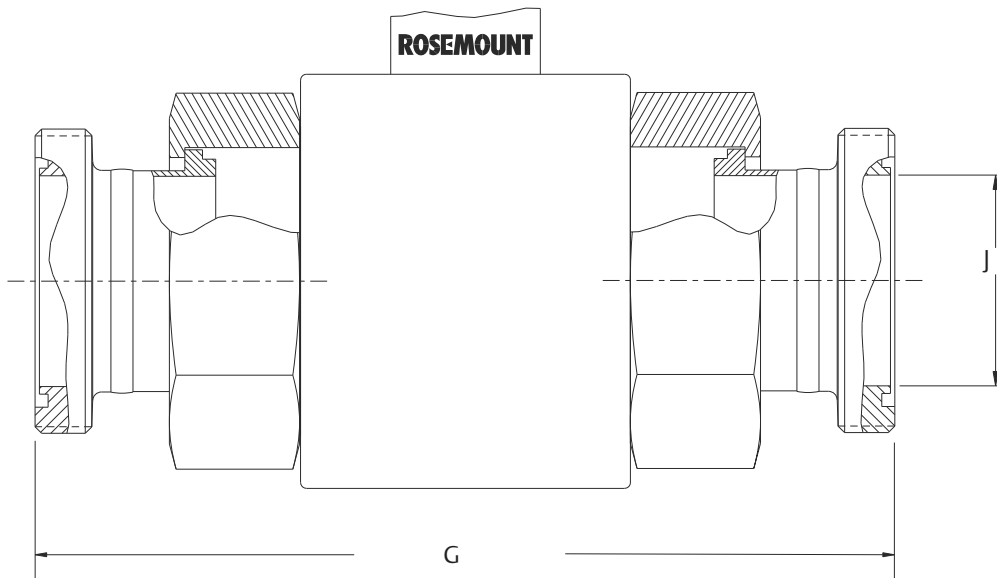
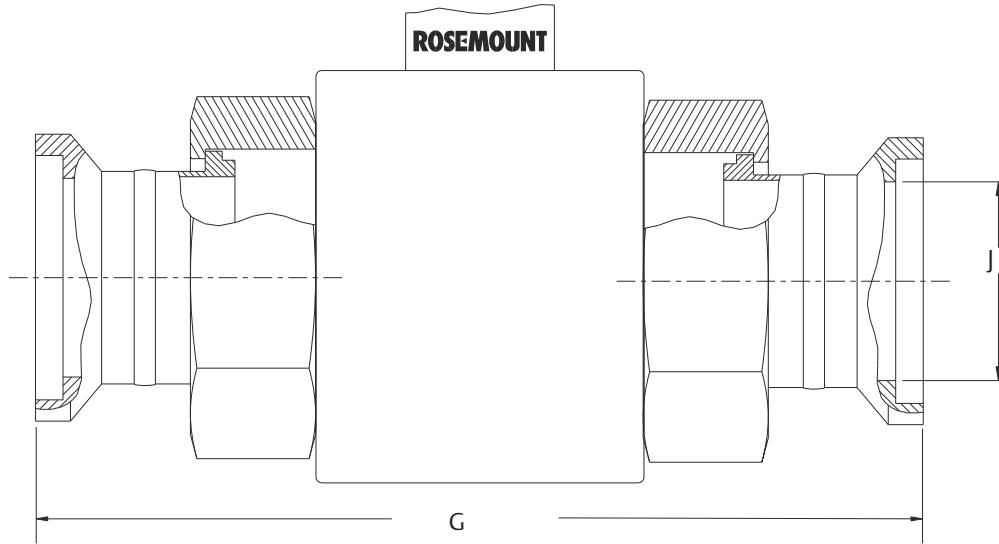
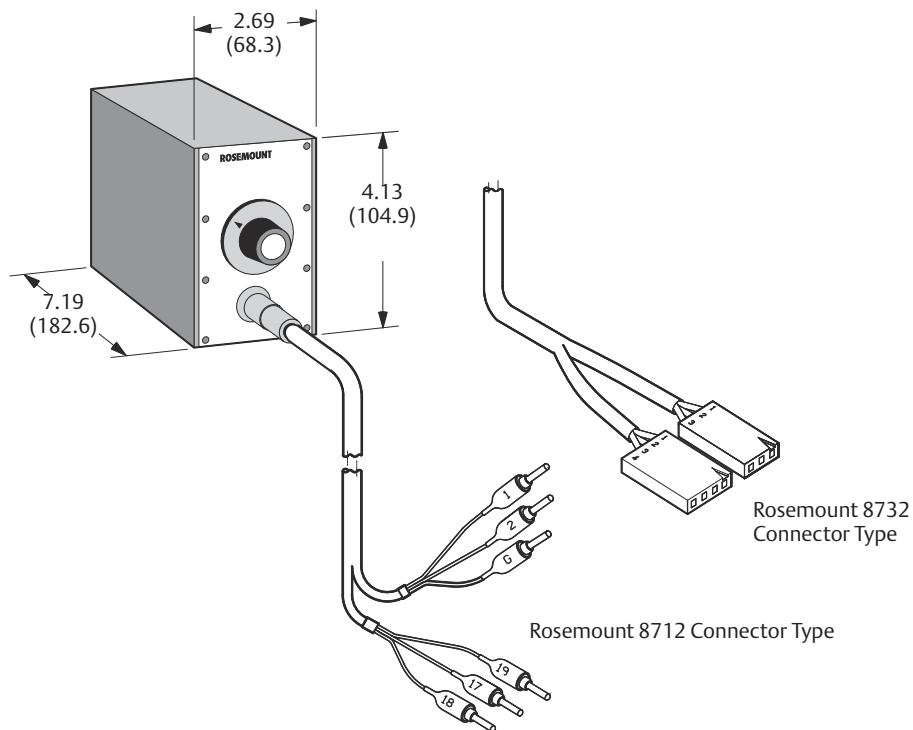

Figure 33: 8721 Hygienic (Sanitary) Sensor Cherry Burrell I-Line



8714 dimensions

Figure 34: 8714D Magnetic Flowmeter Simulator—Calibration Standard



Note

The Rosemount 8714D is shipped with both the 8712 and 8732 Connector Types.

For more information: [Emerson.com/global](https://emerson.com/global)

©2024 Emerson. All rights reserved.

Emerson Terms and Conditions of Sale are available upon request. The Emerson logo is a trademark and service mark of Emerson Electric Co. Rosemount is a mark of one of the Emerson family of companies. All other marks are the property of their respective owners.

ROSEMOUNT™

