

ADDENDUM NO. 1

FOR CONSTRUCTION OF

**OLIVEHURST PUBLIC UTILITIES DISTRICT
PUMP STAION NO. 14 ODOR REHABILITATION PROJECT**

PLUMAS LAKE

YUBA COUNTY, CALIFORNIA

DATE: August 12, 2024

APPROVED BY DESIGNER:



Sean Minard, P.E., P.L.S.

08/12/2024

Date

TO ALL PROSPECTIVE BIDDERS:

All prospective bidders are hereby advised that Addendum No. 1 includes amendments to the Contract Documents that were approved by Olivehurst Public Utilities District on July 15, 2024. The bidders are to review all of the amendments listed herein, and acknowledge receipt of this addendum in the appropriate section of the Proposal Sheet.

**OLIVEHURST PUBLIC UTILITIES DISTRICT
CONTRACT NO. 2024-02**

**Pump Station No. 14 Odor Rehabilitation Project
Yuba County, California**

SUBMIT BID TO:

Olivehurst Public Utilities District
District Engineer Office
c/o Swarnjit Boyal
1970 9th Avenue
Olivehurst, CA 95961

BID OPENING:

Olivehurst Public Utilities District
District Engineer's Office
c/o Swarnjit Boyal
1970 9th Avenue
Olivehurst, CA 95961

**NO LATER THAN: 2:00 P.M. ON THE
DAY OF BID**

**APPROXIMATELY: 2:10 P.M.
FOLLOWING BID SUBMITTAL**

TO: Honorable Board of Directors
Olivehurst Public Utilities District

Add Alternate E

Bid Item	Sub Item	Description	Estimated Quantity	Unit	Unit Price	Total
E		Existing Wet Well Guide Rail Replacement				
	E.1	Replacement of existing 2-inch diameter guide rail system for all three pumps (Two 35 feet long sched. 40 stainless steel rails and two stainless steel intermediate guide bar brackets per pump)	1	JOB	XXXXXXXX	
			ADD ALTERNATE E TOTAL			

Notes:

AC = acre; BCY = bank cubic yard; CY = cubic yard; CCY = compacted cubic yard; EV = event; EA = each; LF = linear feet LCY = loose cubic yard; JOB = job; LS = lump sum; MO = month; SF = square foot; SY = square yard; (F) = Final Pay Quantity

- All quantities are in-place quantities.
- Prices must be submitted on all individual items for the Bid Schedule(s). Failure to submit Unit Prices or Lump Sum prices will result in rejection of the bid as non-responsive.
- See General Specification Section 8-1 regarding payment for mobilization and demobilization.
- In the event the extended amounts shown hereon do not equal the product of the estimated quantity and the unit price, the unit price shall govern and the corrected extended amount shall be utilized to determine the total price of the bid.

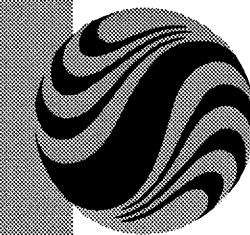

Stantec

Copyright Reserved
The Contractor shall verify and be responsible for all dimensions. DO NOT scale the drawing - any errors or omissions shall be reported to Stantec Consulting Inc. without delay.
The Copyrights to all designs and drawings are the property of Stantec Consulting Inc. Reproduction or use for any purpose other than that authorized by Stantec Consulting Inc. is forbidden.

Notes

RIO DEL ORO PUMPING PLANT #3

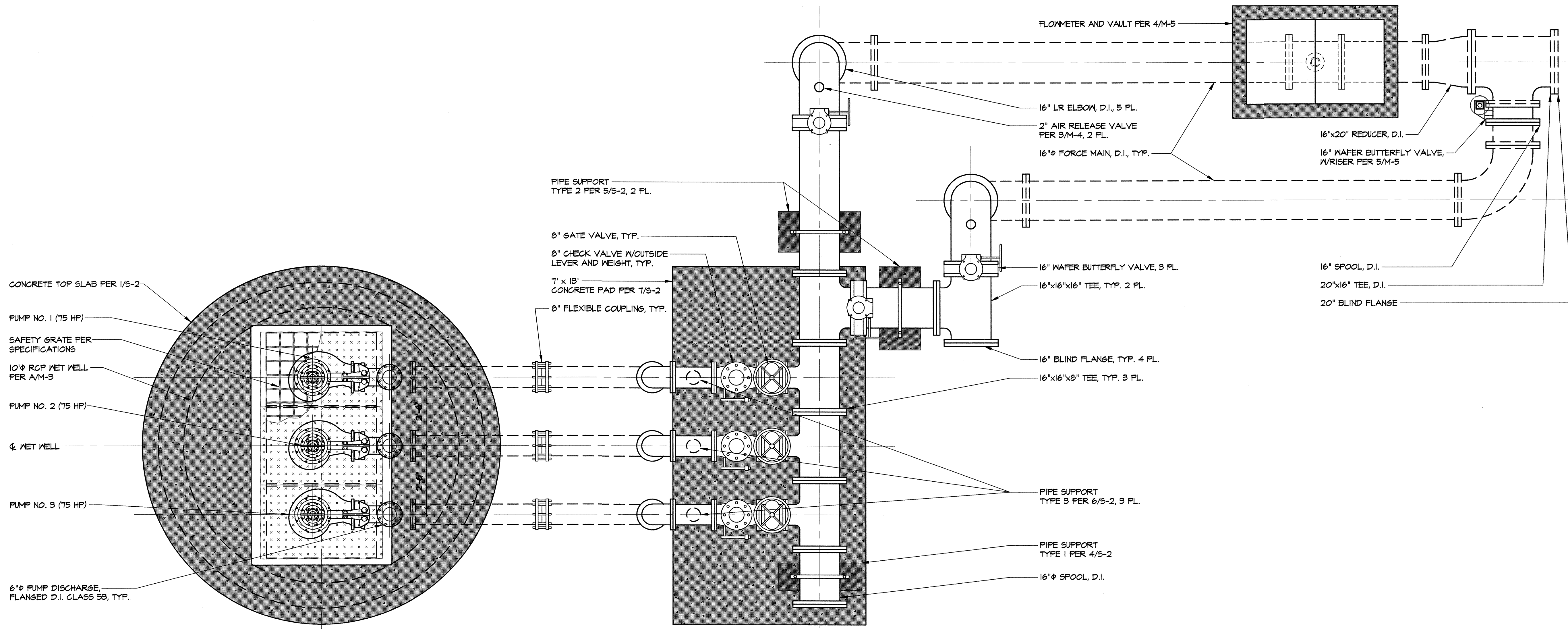

WET WELL #1 - PLAN VIEW

SCALE: 1/2" = 1'-0"

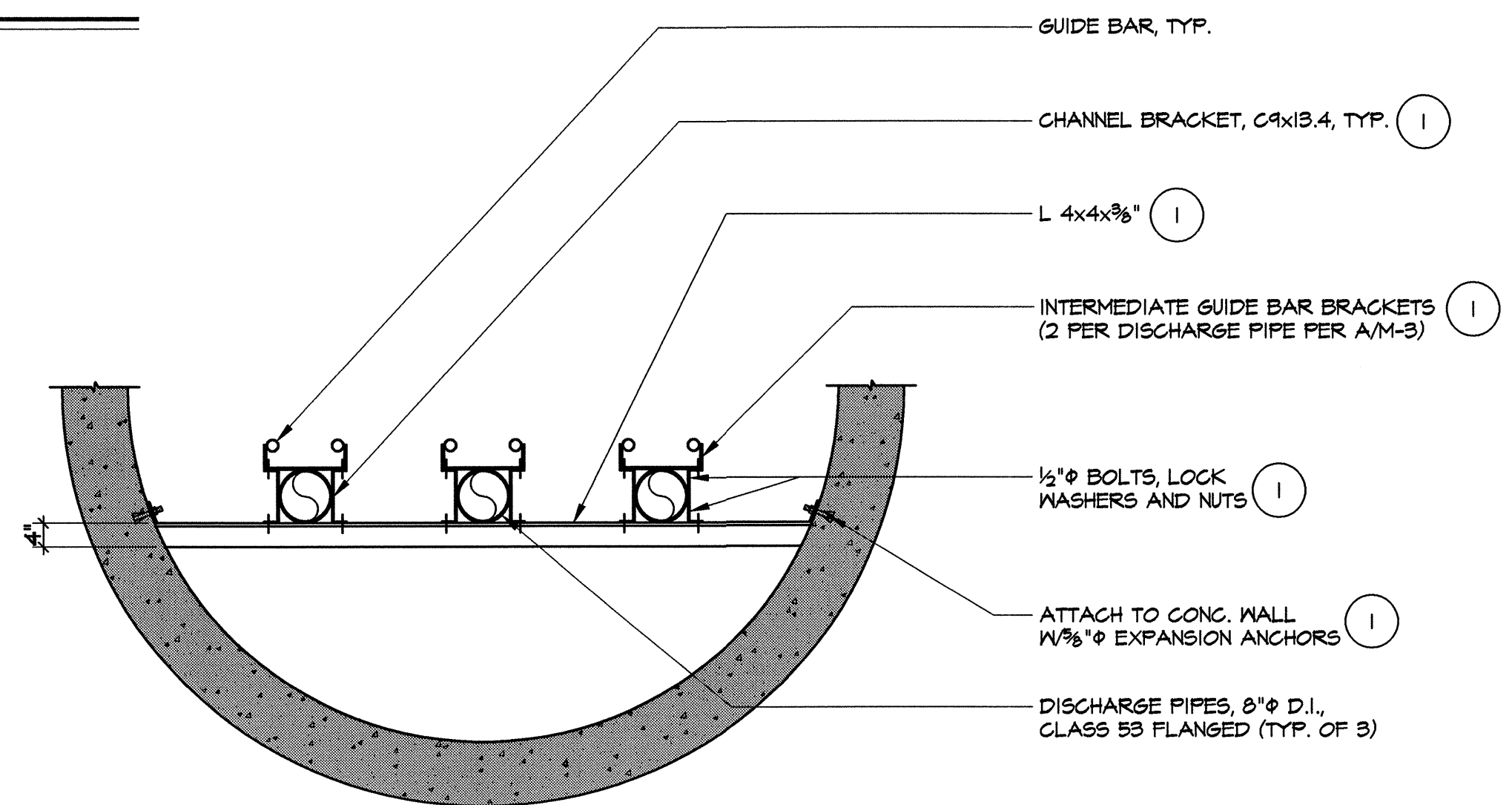

PIPE SUPPORT DETAIL

SCALE: NONE

NOTE
ALL BRACKETS, HARDWARE AND FASTENERS SHALL BE TYPE 304 OR 316 SST

RECORD DRAWING

Revision	By	Appd.	Date

Issued	By	Appd.	Date

File Name:	GC	BB	AJ	2-26-03
Dwn.	Chkd.	Degn.	Date	

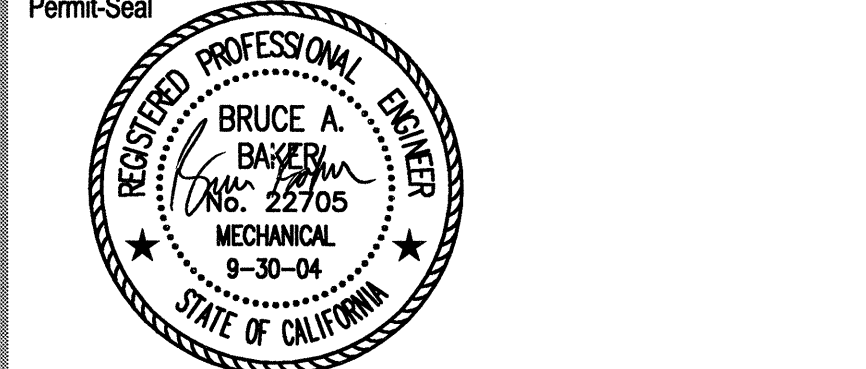

Owner/Project
PLUMAS LAKE OWNERSHIP GROUP
RIO DEL ORO
PUMPING PLANT #3

RIO DEL ORO
Yuba County, California

Title
PLAN AND DETAILS

Project No.	Scale	
84263001	AS NOTED	
Drawing No.	Sheet	Revision
M-2	7 of 17	0

I acknowledge receipt of Addendum Number 1 to the subject project and accept all conditions contained herein. The information and revisions presented in this Addendum has been considered in preparation of my proposal.

Bidder: _____

Signature: _____ Date: _____

Title: _____